

COMMON DIMENSIONS

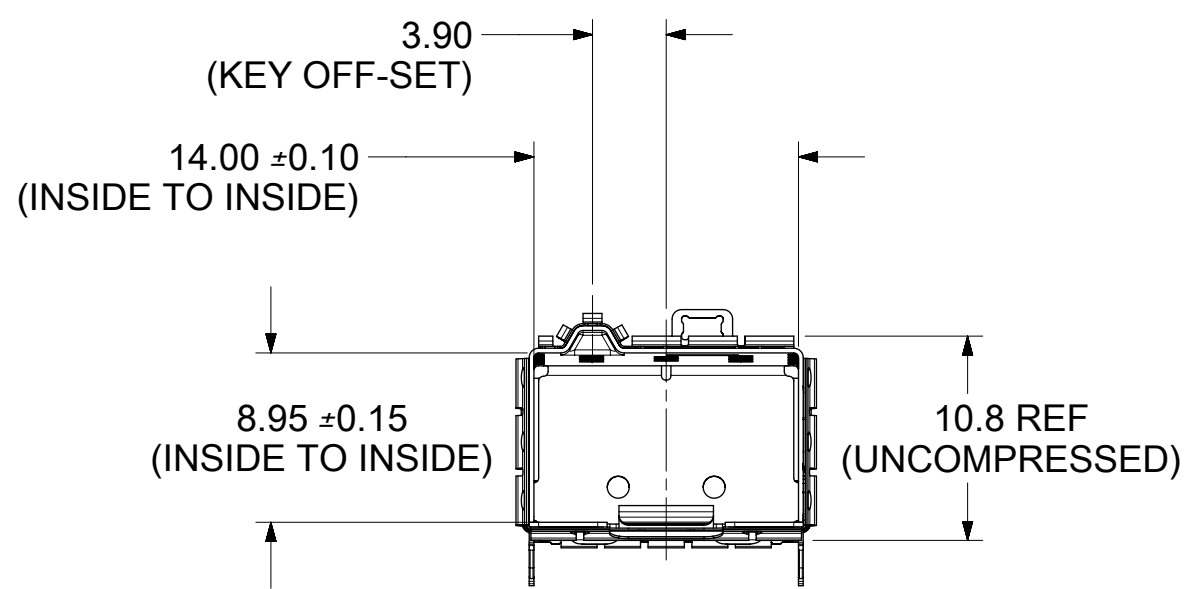

WEEK/YEAR DATE CODE TABLE	
WK	WEEK 01 THROUGH 52. EXAMPLE: 01 - FIRST WEEK OF YEAR, 52 - LAST WEEK OF YEAR
YR	LAST TWO DIGITS OF THE YEAR, 19, 20, 21, ETC. EXAMPLE: 2019 = 19

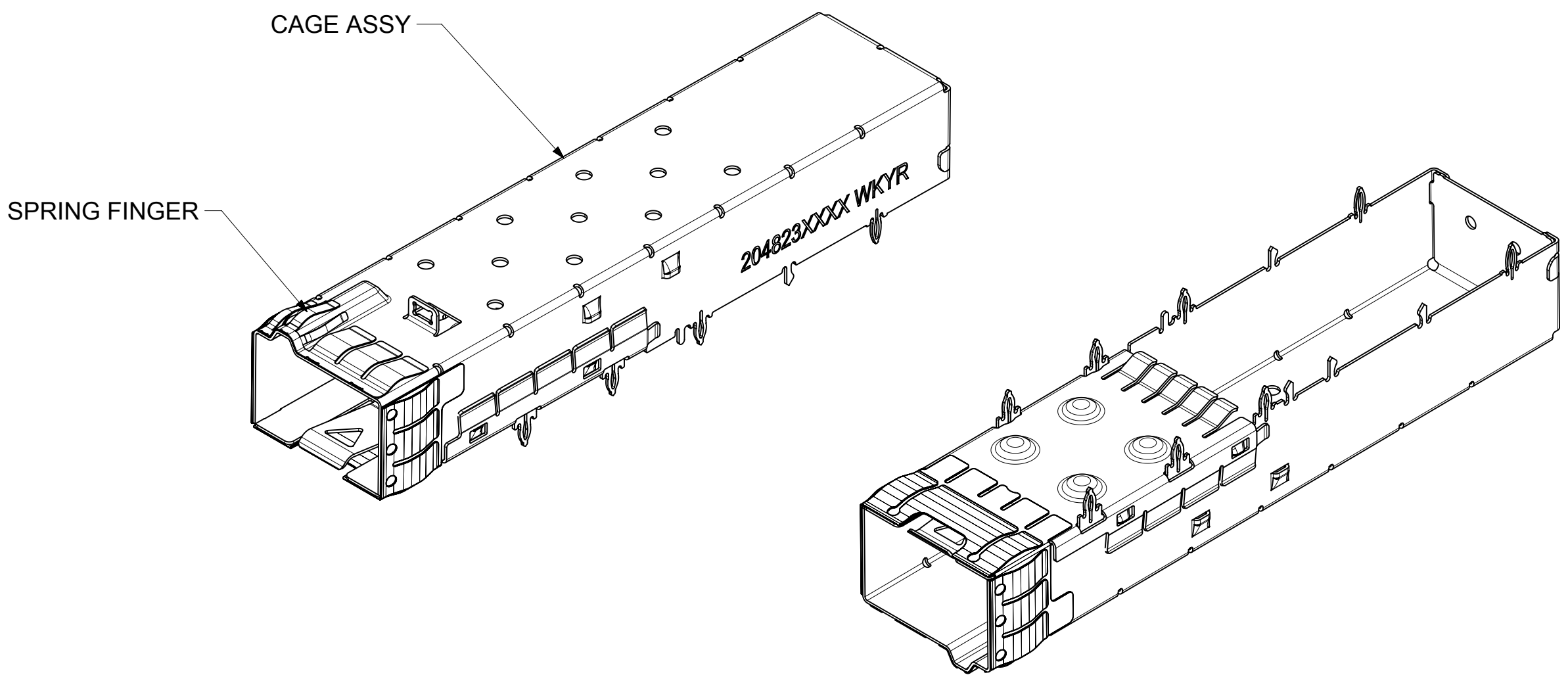
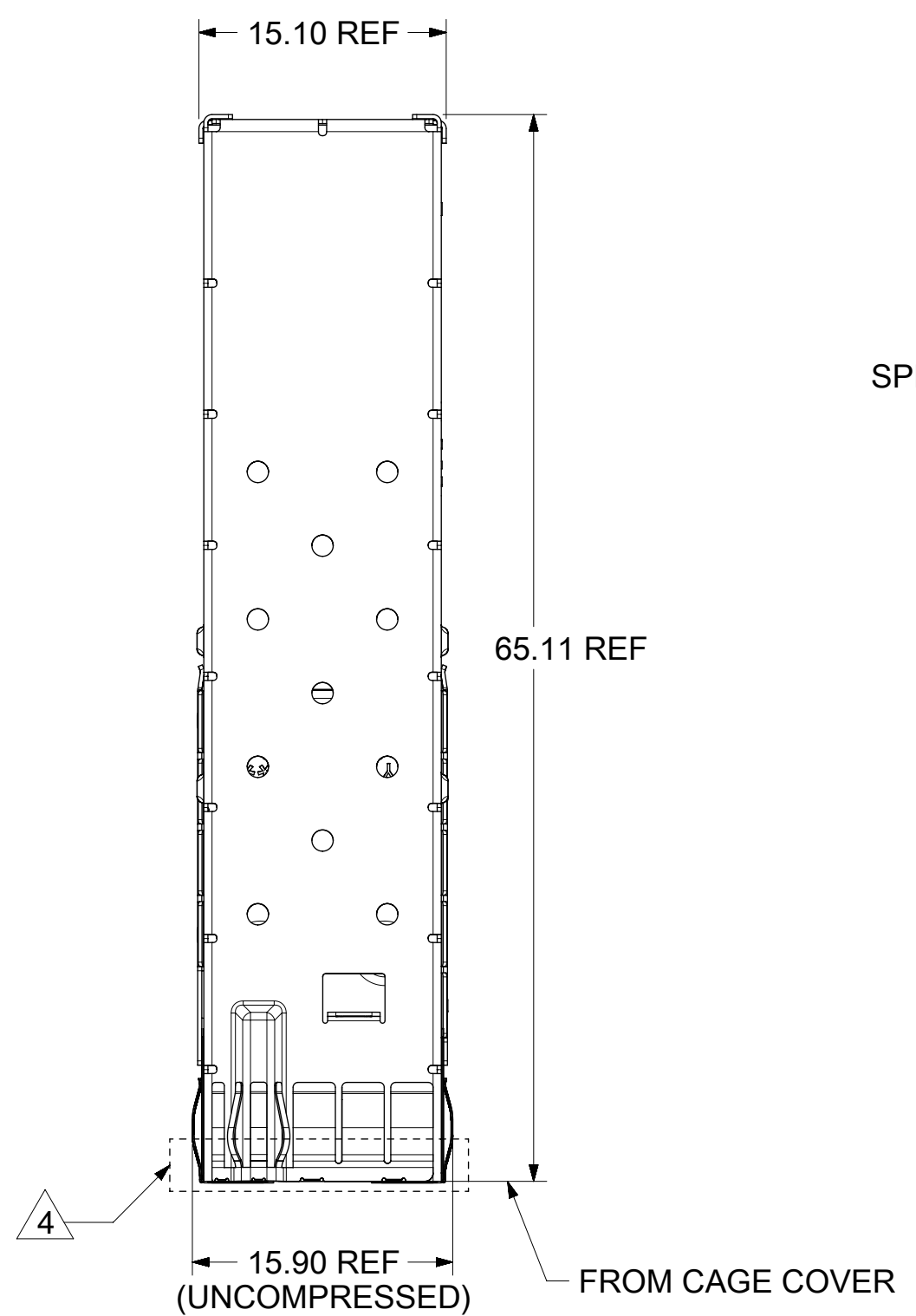
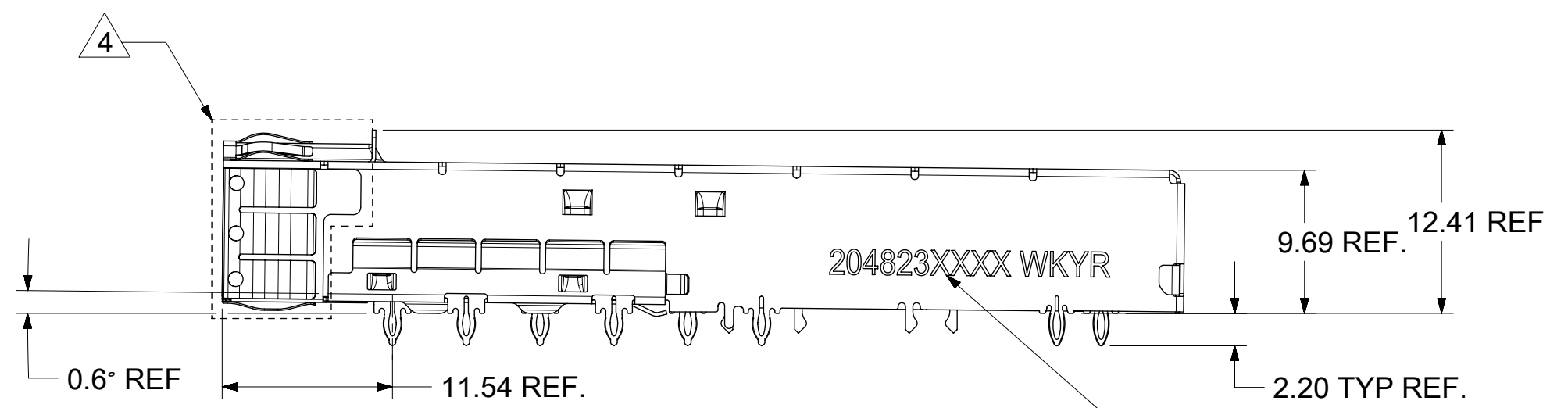

PART NO. AND WEEK/YEAR DATE CODE TO BE PRINTED OR LASERED ON THE SIDE OF COMPLETED CAGE ASSEMBLY APPROXIMATELY AS SHOWN

- NOTES:
- MATERIAL:
 CAGE: 0.25mm THICKNESS, STAINLESS STEEL.
 FRONT SPRING FINGERS: 0.1mm THICK COPPER ALLOY, NICKEL PLATED.
 HEATSINK: ALUMINUM, BLACK ANODIZATION
 HEATSINK CLIP: STAINLESS STEEL
 - PRESS FIT LEGS 2.2mm LONG:
 1.57mm±10% PCB THICKNESS FOR SINGLE SIDED MOUNT.
 2.55mm MINIMUM PCB THICKNESS FOR BELLY TO BELLY MOUNT.
 - PORTS ARE DESIGNED FOR SFP-DD TRANSCEIVERS.
 THE TOP SURFACE OF THE MODULE MUST BE FLAT (NO PRODUCT LABEL RECESS) AND THERMALLY CONDUCTIVE TO OPTIMAL FUNCTION.
 - WELD SPOTS WILL SHOW SLIGHT MATERIAL DISCOLORATION.
 - NO RoHS EXEMPTIONS.

THIS DRAWING CONTAINS INFORMATION THAT IS PROPRIETARY TO MOLEX ELECTRONIC TECHNOLOGIES, LLC AND SHOULD NOT BE USED WITHOUT WRITTEN PERMISSION									
DIMENSION UNITS		SCALE		CURRENT REV DESC:				molex	
mm		2.5:1							
GENERAL TOLERANCES (UNLESS SPECIFIED)				EC NO: 626123				SFP-DD 1X1 CAGE ASSY, PCI VERSION, SPRING FINGER TYPE, 0 REAR LEG, W/ HEATSINK OPTIONS	
ANGULAR TOL ± 2.0°				DRWN: ASYAMIKAR 2019/10/23					
4 PLACES ±				CHK'D: TKUMARKC 2019/10/24				PRODUCT CUSTOMER DRAWING	
3 PLACES ±				APPR: JCHIANG 2019/10/24					
2 PLACES ± 0.13				INITIAL REVISION:				DOCUMENT NUMBER	
1 PLACE ± 0.25				DRWN: TKUMARKC 2018/09/27					
0 PLACES ±				APPR: RCHEN08 2018/12/04				DOC TYPE	
DRAFT WHERE APPLICABLE MUST REMAIN WITHIN DIMENSIONS				THIRD ANGLE PROJECTION		DRAWING		DOC PART	
		C-SIZE		SERIES		MATERIAL NUMBER		REVISION	
		C-SIZE		204823		SEE SHEET 3		PSD ASY C2	
				CUSTOMER		SHEET NUMBER			
						1 OF 10			

(HEAT SINK, CLIP AND LIGHT PIPE NOT SHOWN FOR CLARITY)

2048238201 SHOWN

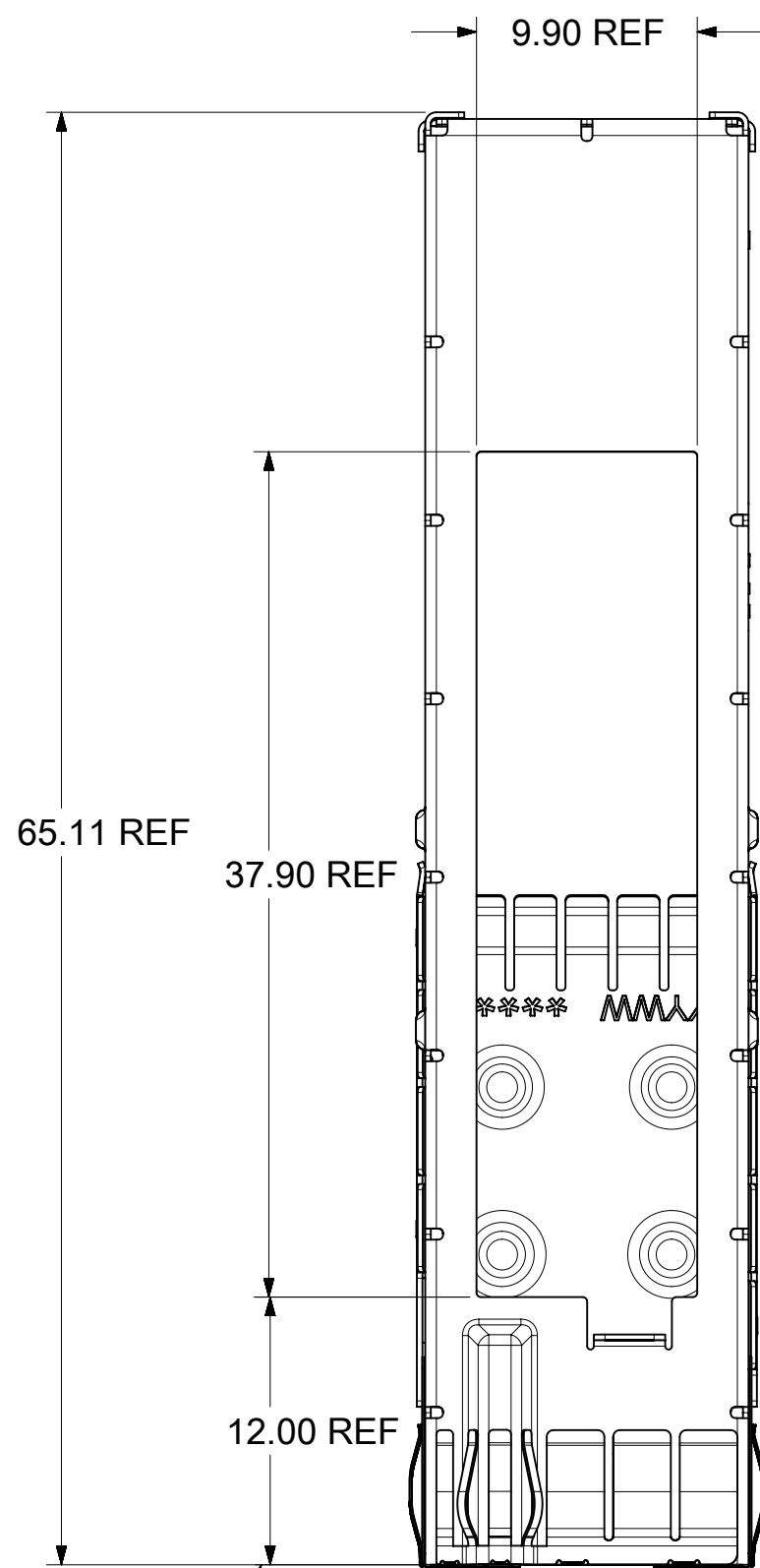

FROM CAGE COVER

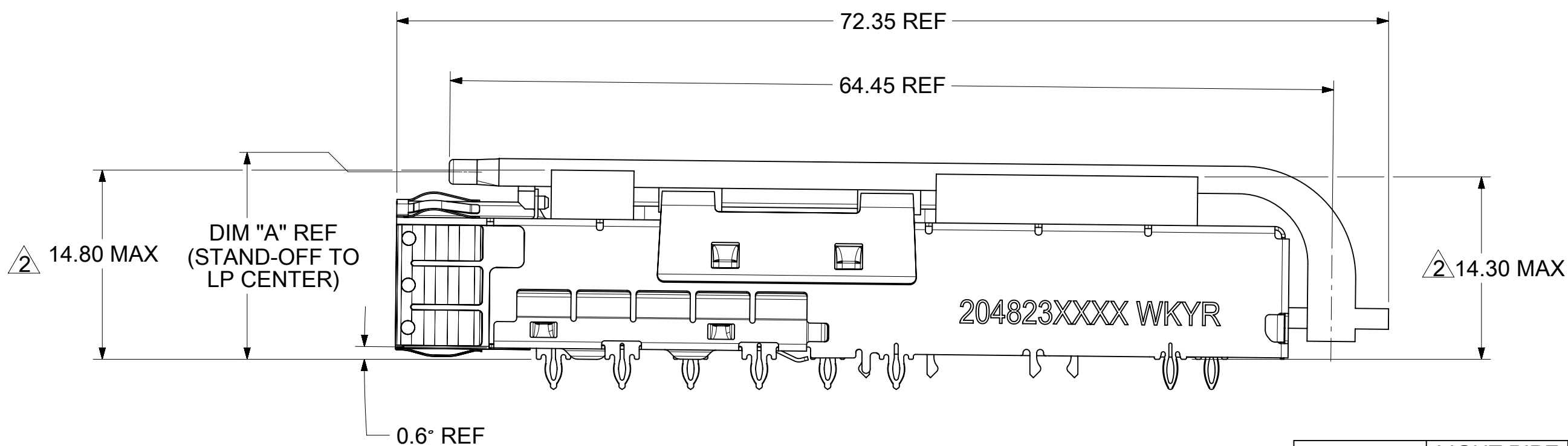
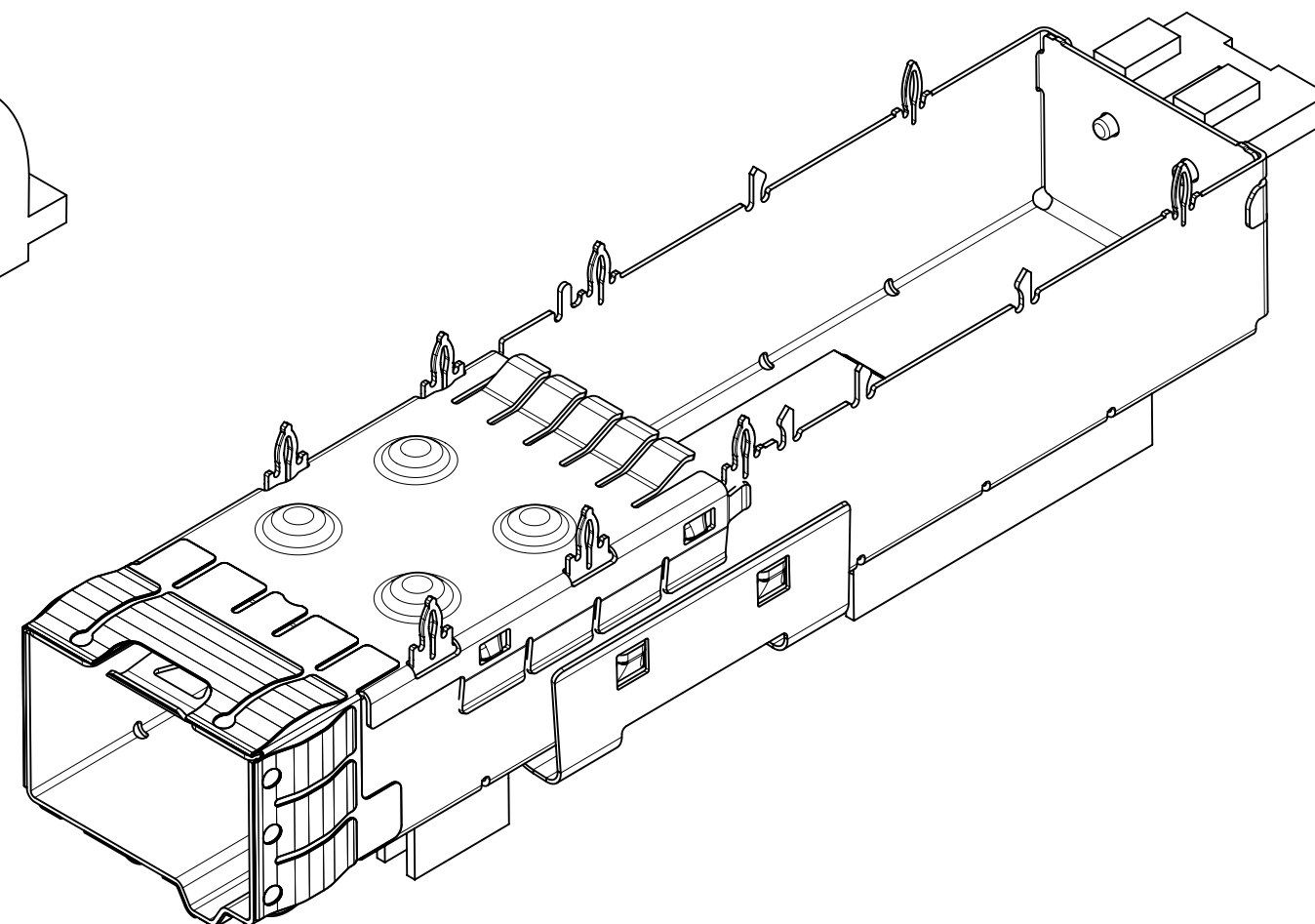
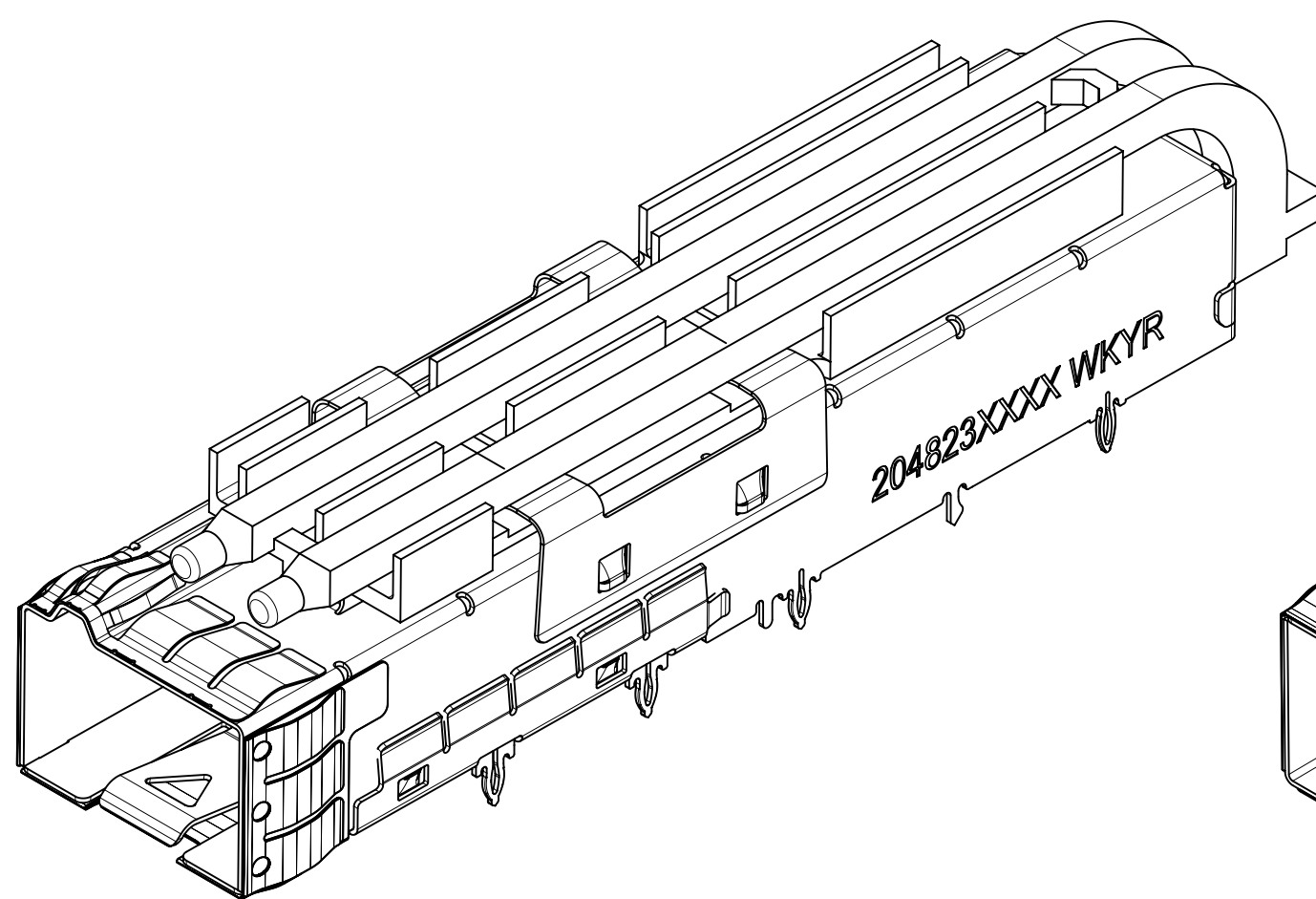
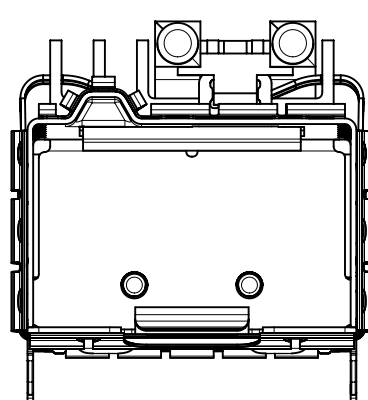

P/N	LIGHT PIPE OPTION	DIM "A"
2048238101	SINGLE	14.7
2048238201	DUAL	13.6

THIS DRAWING CONTAINS INFORMATION THAT IS PROPRIETARY TO MOLEX ELECTRONIC TECHNOLOGIES, LLC AND SHOULD NOT BE USED WITHOUT WRITTEN PERMISSION

DIMENSION UNITS	SCALE	CURRENT REV	DESC:
mm	3:1		
GENERAL TOLERANCES (UNLESS SPECIFIED)			
ANGULAR TOL	± 2.0°		
4 PLACES	±		
3 PLACES	±		
2 PLACES	± 0.13		
1 PLACE	± 0.25		
0 PLACES	±		
DRAFT WHERE APPLICABLE MUST REMAIN WITHIN DIMENSIONS		THIRD ANGLE PROJECTION	DRAWING SERIES
			C-SIZE 204823

molex			
SFP-DD 1X1 CAGE ASSY, PCI VERSION, SPRING FINGER TYPE, 0 REAR LEG, W/ HEATSINK OPTIONS			
PRODUCT CUSTOMER DRAWING			
DOCUMENT NUMBER	DOC TYPE	DOC PART	REVISION
2048238001	PSD	ASY	C2
MATERIAL NUMBER	CUSTOMER	SHEET NUMBER	
SEE SHEET 3		2 OF 10	

NOTE:
 1. REFER TO SHEET ONE FOR COMMON FEATURES AND REQUIREMENTS.
 2. HEIGHT OF HEAT SINK WITH MODULE INSERTED.
 DIMENSION MAY BE LESS DUE TO MODULE AND HEAT SINK VARIATIONS

DOCUMENT STATUS	P1	RELEASE DATE	2019/10/24	11:52:29
-----------------	----	--------------	------------	----------

PART NUMBER SELECTION

NO HEATSINK
NO LIGHT PIPES
CLOSE TOP

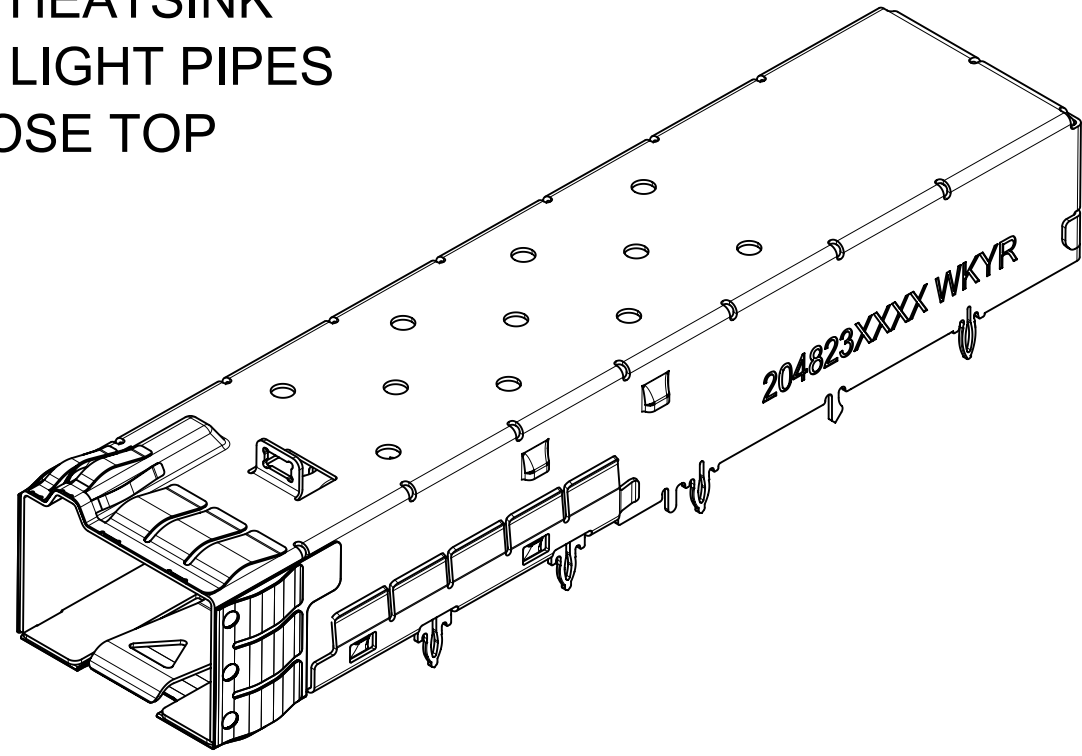

MOLEX P/N	#OF REAR LEGS PER PORT
2048238001	0

NO HEATSINK
NO LIGHT PIPES
OPEN TOP

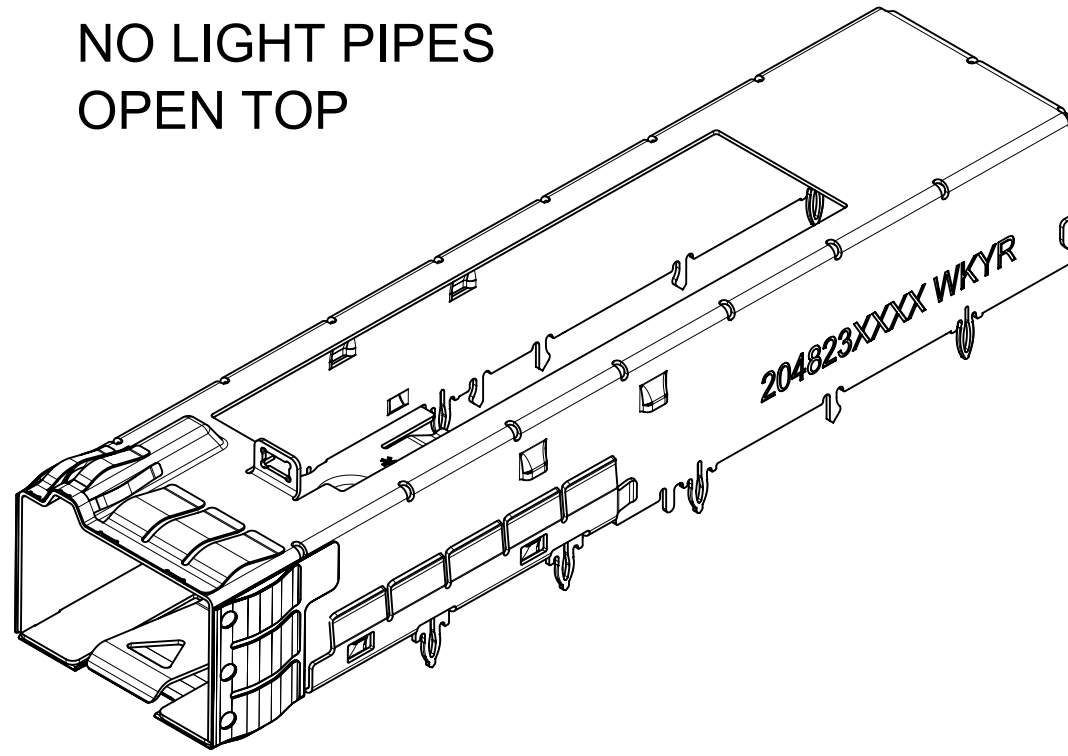

MOLEX P/N	#OF REAR LEGS PER PORT
2048238002	0

WITH HEATSINK

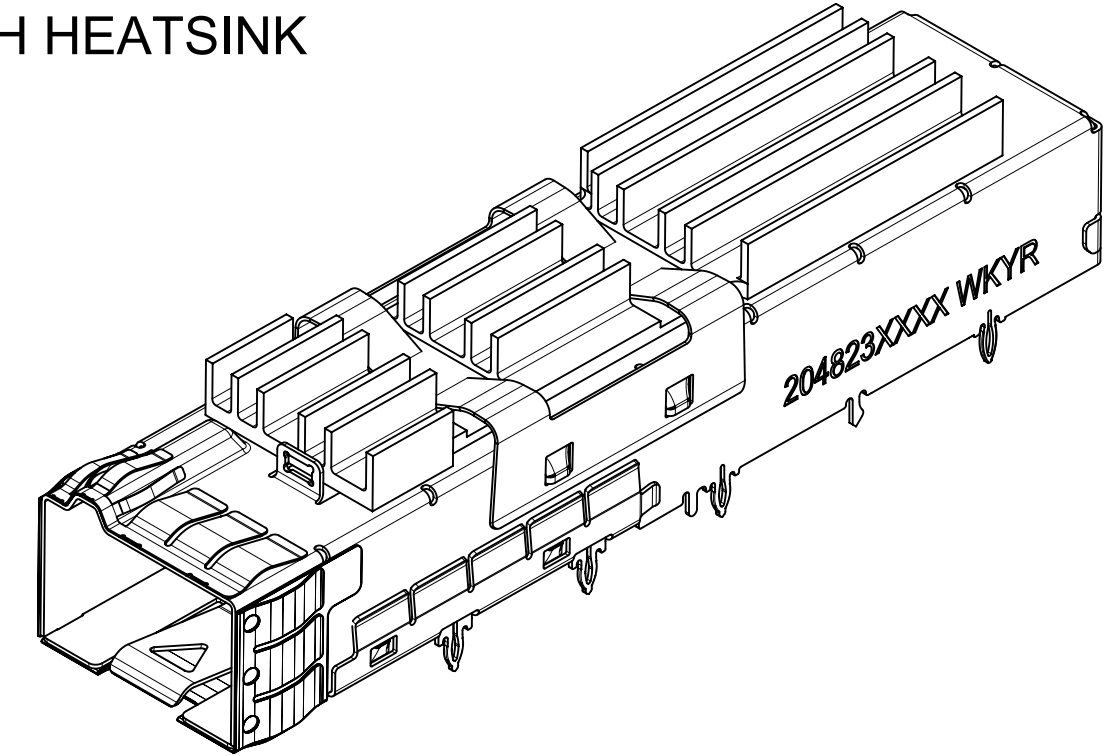

MOLEX P/N	HEATSINK	#OF REAR LEGS PER PORT
2048238003	PCI	0

HEATSINK
W/SINGLE LIGHT PIPES

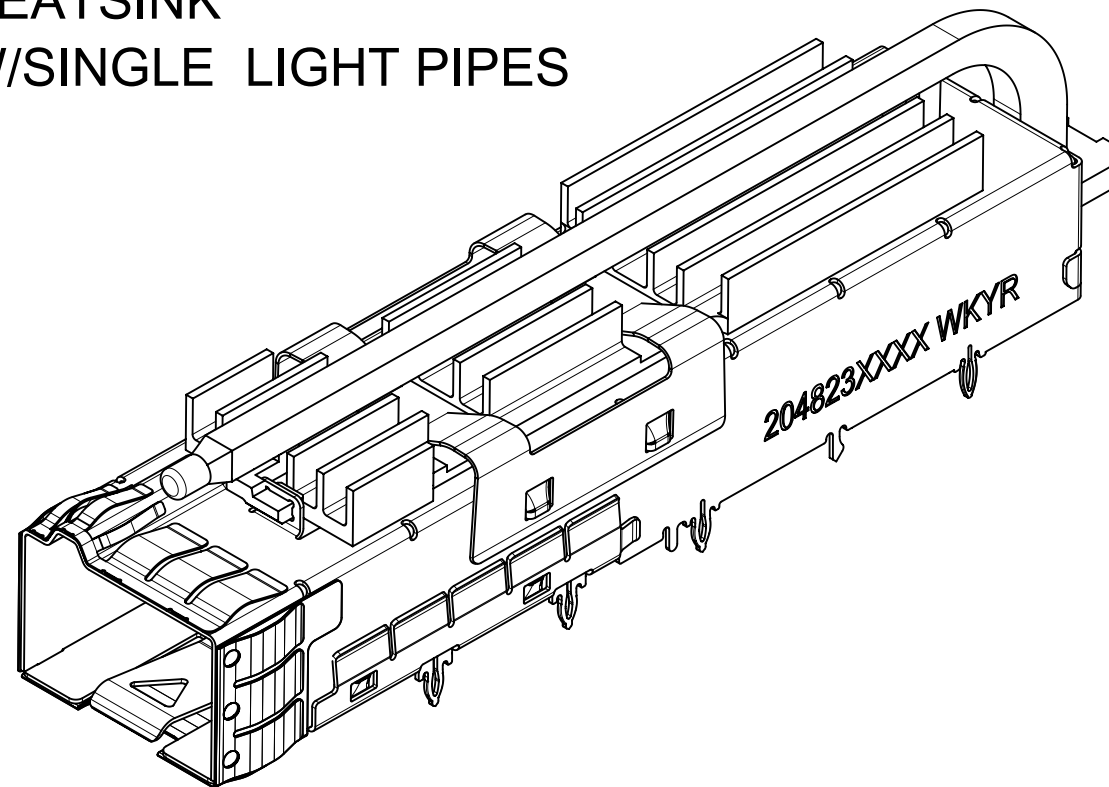

MOLEX P/N	HEATSINK	#OF REAR LEGS PER PORT
2048238101	PCI	0

HEATSINK
W/ DUAL LIGHT PIPES

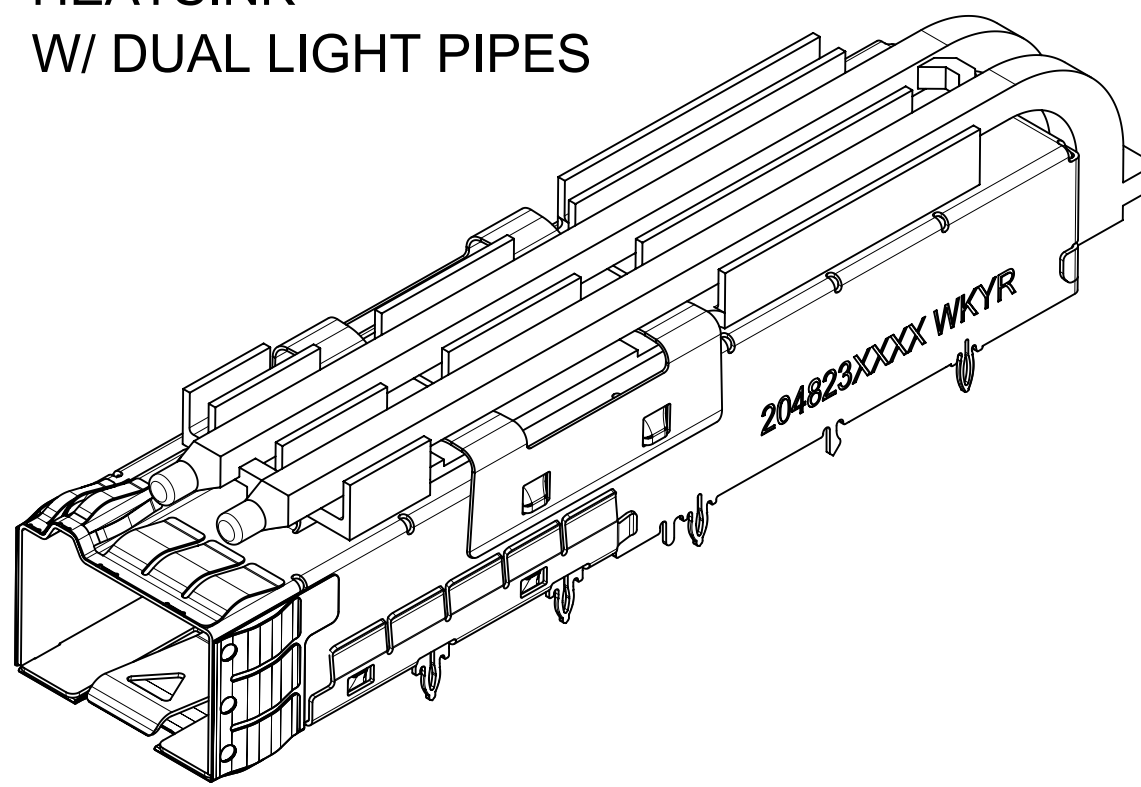

MOLEX P/N	HEATSINK	#OF REAR LEGS PER PORT
2048238201	PCI	0

THIS DRAWING CONTAINS INFORMATION THAT IS PROPRIETARY TO MOLEX ELECTRONIC TECHNOLOGIES, LLC AND SHOULD NOT BE USED WITHOUT WRITTEN PERMISSION

DIMENSION UNITS	SCALE	CURRENT REV	DESC:
mm	2.5:1		
GENERAL TOLERANCES (UNLESS SPECIFIED)		EC NO: 626123	
ANGULAR TOL	± 2.0°	DRWN: ASYAMIKAR	2019/10/23
4 PLACES	±	CHK'D: TKUMARKC	2019/10/24
3 PLACES	±	APPR: JCHIANG	2019/10/24
2 PLACES	± 0.13	INITIAL REVISION:	
1 PLACE	± 0.25	DRWN: TKUMARKC	2018/09/27
0 PLACES	±	APPR: RCHEN08	2018/12/04
DRAFT WHERE APPLICABLE MUST REMAIN WITHIN DIMENSIONS		THIRD ANGLE PROJECTION	DRAWING
			C-SIZE
		SERIES	204823
DOCUMENT NUMBER		DOC TYPE	DOC PART
2048238001		PSD	ASY
MATERIAL NUMBER		CUSTOMER	SHEET NUMBER
SEE SHEET 3			3 OF 10

molex

SFP-DD 1X1 CAGE ASSY, PCI VERSION, SPRING FINGER TYPE, 0 REAR LEG, W/ HEATSINK OPTIONS

PRODUCT CUSTOMER DRAWING

DOCUMENT NUMBER: 2048238001, DOC TYPE: PSD, DOC PART: ASY, REVISION: C2

MATERIAL NUMBER: SEE SHEET 3, CUSTOMER: , SHEET NUMBER: 3 OF 10

PCB LAYOUT FOR SINGLE SIDE MOUNT

HOST CONNECTOR DETAILS

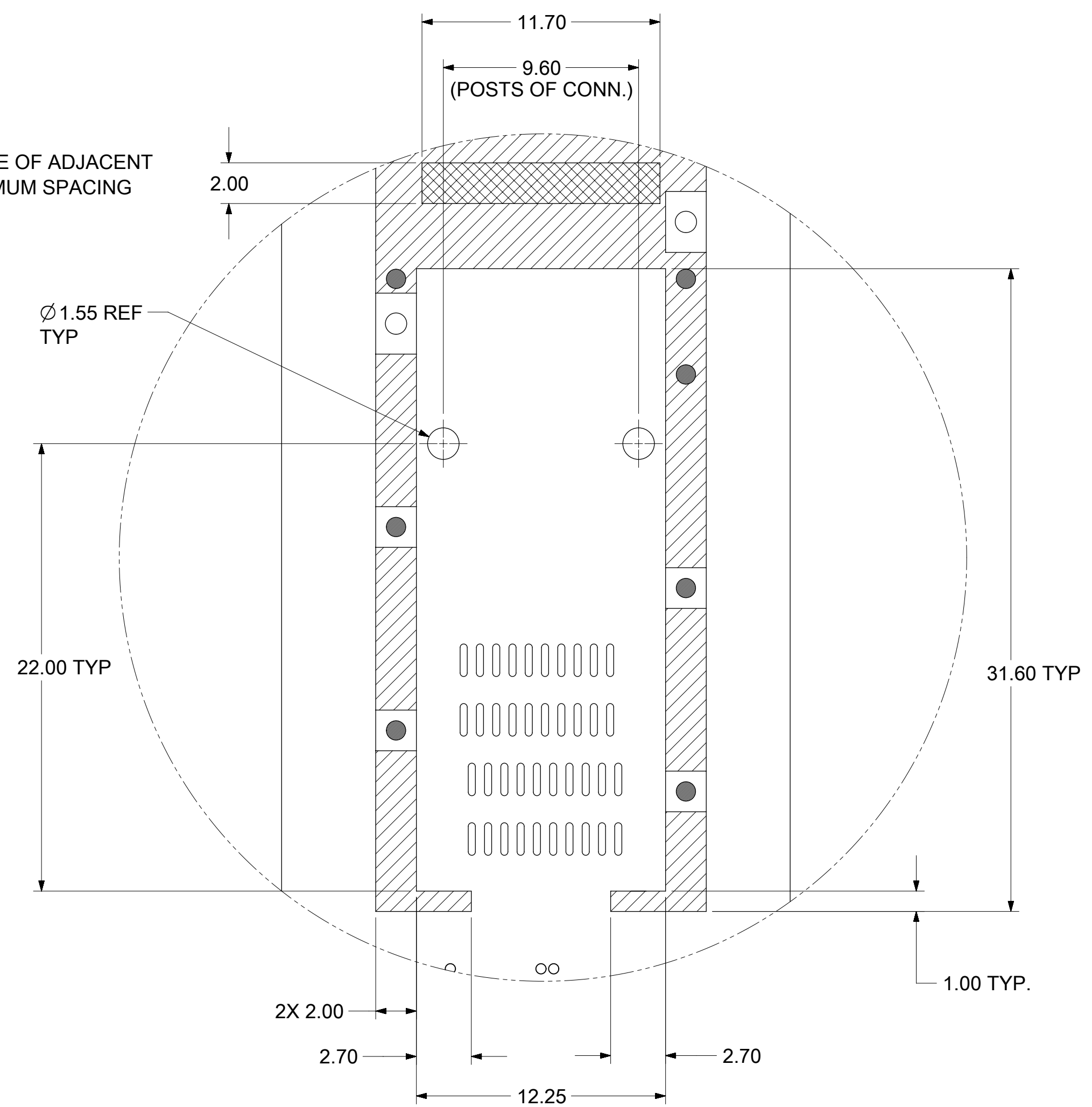
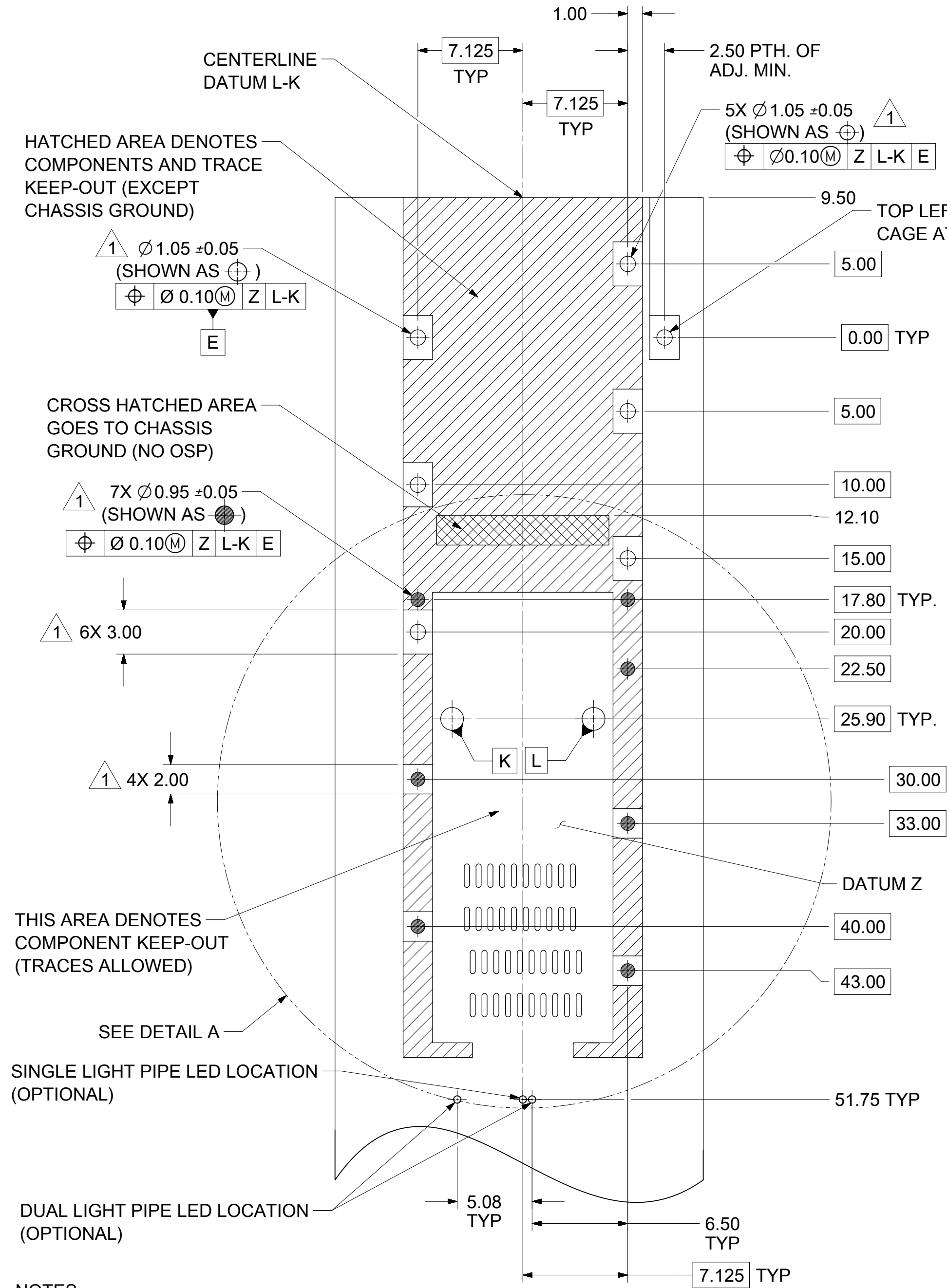

DETAIL A
SCALE 5:1

THIS DRAWING CONTAINS INFORMATION THAT IS PROPRIETARY TO MOLEX ELECTRONIC TECHNOLOGIES, LLC AND SHOULD NOT BE USED WITHOUT WRITTEN PERMISSION									
DIMENSION UNITS		SCALE		CURRENT REV DESC:					
mm		4:1							
GENERAL TOLERANCES (UNLESS SPECIFIED)				EC NO: 626123					
ANGULAR TOL ± 2.0°				DRWN: ASYAMIKAR		2019/10/23		SFP-DD 1X1 CAGE ASSY, PCI VERSION, SPRING FINGER TYPE, 0 REAR LEG, W/ HEATSINK OPTIONS	
4 PLACES ±				CHK'D: TKUMARKC		2019/10/24		PRODUCT CUSTOMER DRAWING	
3 PLACES ±				APPR: JCHIANG		2019/10/24		DOCUMENT NUMBER	
2 PLACES ± 0.13				INITIAL REVISION:				DOC TYPE DOC PART REVISION	
1 PLACE ± 0.25				DRWN: TKUMARKC		2018/09/27		2048238001	
0 PLACES ±				APPR: RCHEN08		2018/12/04		PSD ASY C2	
DRAFT WHERE APPLICABLE MUST REMAIN WITHIN DIMENSIONS			THIRD ANGLE PROJECTION		DRAWING		SERIES		MATERIAL NUMBER
			C-SIZE		204823		SEE SHEET 3		CUSTOMER
									SHEET NUMBER
									4 OF 10

PCB LAYOUT FOR BELLY TO BELLY MOUNT

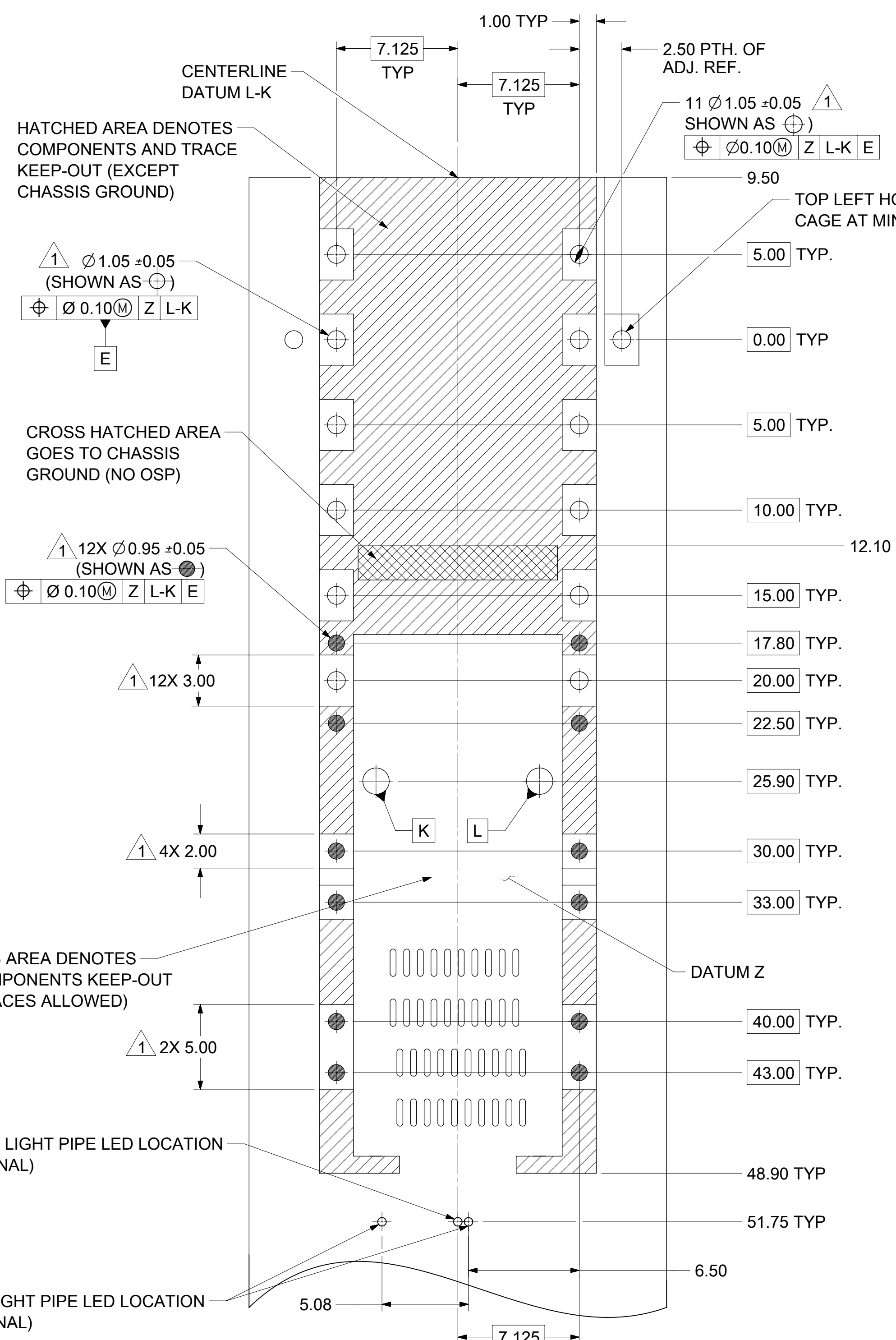

SEE SHEET 4 FOR HOST CONNECTOR POST DETAIL

- NOTES:
- PADS AND VIAS CONNECT TO CHASSIS GROUND
 - RECOMMENDED THRU HOLE PLATING INCLUDES HASL, OSP, OR IMMERSION (GOLD, SILVER, OR TIN).
 - CONNECTOR PAD LAYOUT PER SFP-DD MSA WILL ACCOMMODATE MOLEX CONNECTOR SERIES 204730 OR EQUIVALENT.
 - MIN PCB THICKNESS FOR BELLY TO BELLY USE 2.55MM

THIS DRAWING CONTAINS INFORMATION THAT IS PROPRIETARY TO MOLEX ELECTRONIC TECHNOLOGIES, LLC AND SHOULD NOT BE USED WITHOUT WRITTEN PERMISSION									
DIMENSION UNITS: mm		SCALE: 5:1		CURRENT REV DESC:				molex	
GENERAL TOLERANCES (UNLESS SPECIFIED)		EC NO: 626123		SFP-DD 1X1 CAGE ASSY, PCI VERSION, SPRING FINGER TYPE, 0 REAR LEG, W/ HEATSINK OPTIONS					
ANGULAR TOL $\pm 2.0^\circ$		4 PLACES \pm		DRWN: ASYAMIKAR 2019/10/23		CHK'D: TKUMARKC 2019/10/24		PRODUCT CUSTOMER DRAWING	
3 PLACES \pm		2 PLACES ± 0.13		APPR: JCHIANG 2019/10/24		INITIAL REVISION:		DOCUMENT NUMBER	
1 PLACE ± 0.25		0 PLACES \pm		DRWN: TKUMARKC 2018/09/27		APPR: RCHEN08 2018/12/04		2048238001	
DRAFT WHERE APPLICABLE MUST REMAIN WITHIN DIMENSIONS		THIRD ANGLE PROJECTION		DRAWING: C-SIZE		SERIES: 204823		MATERIAL NUMBER: SEE SHEET 3	
DOC STATUS: P1		RELEASE DATE: 2019/10/24 11:52:29		DOC TYPE: PSD		DOC PART: ASY		REVISION: C2	
SHEET NUMBER: 5 OF 10									

KEEP OUT AREA FOR INSERTION/EXTRACTION TOOL

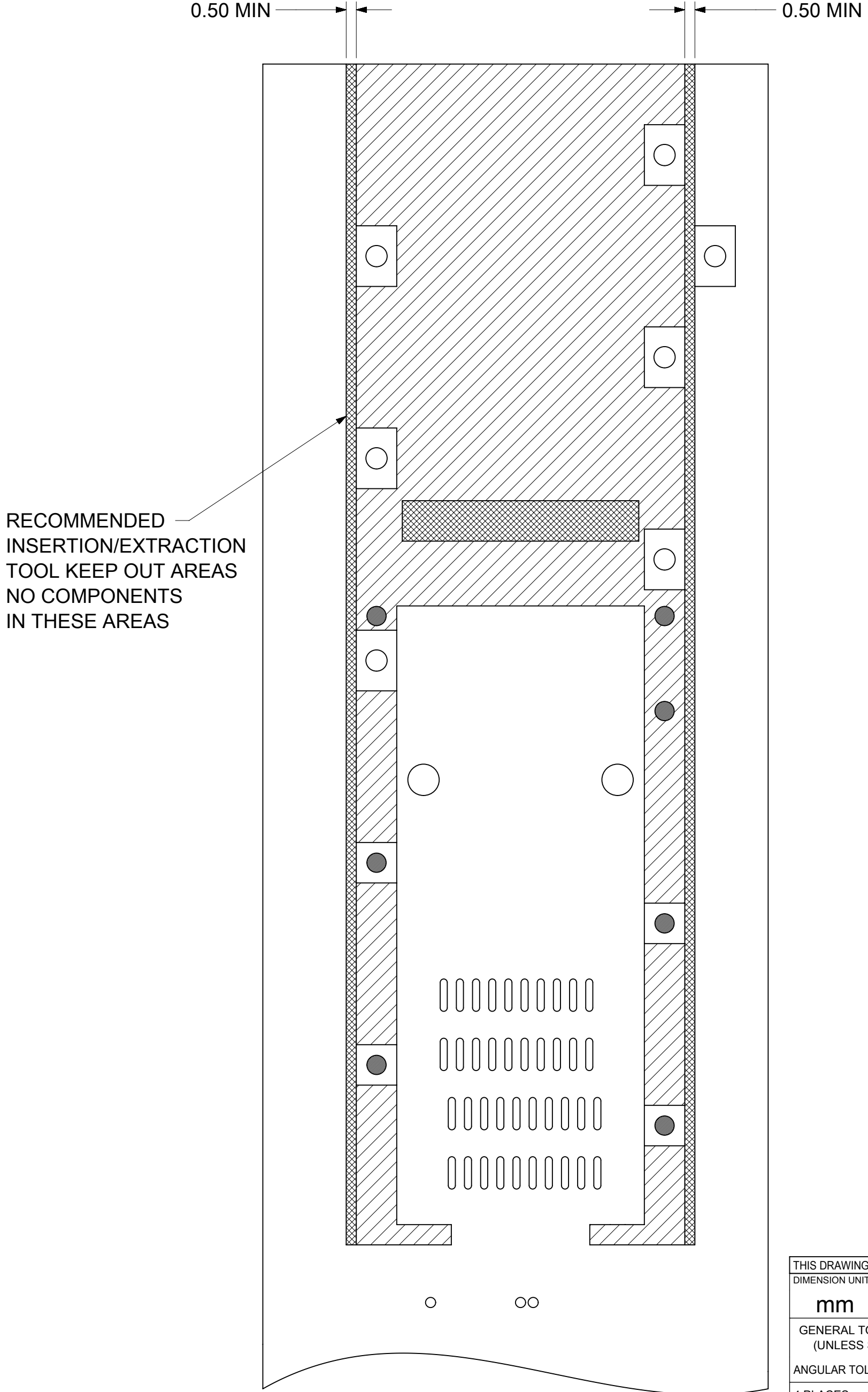

THIS DRAWING CONTAINS INFORMATION THAT IS PROPRIETARY TO MOLEX ELECTRONIC TECHNOLOGIES, LLC AND SHOULD NOT BE USED WITHOUT WRITTEN PERMISSION									
DIMENSION UNITS		SCALE		CURRENT REV DESC:				molex	
mm		5:1							
GENERAL TOLERANCES (UNLESS SPECIFIED)				EC NO: 626123				SFP-DD 1X1 CAGE ASSY, PCI VERSION, SPRING FINGER TYPE, 0 REAR LEG, W/ HEATSINK OPTIONS	
ANGULAR TOL ± 2.0°				DRWN: ASYAMIKAR 2019/10/23					
4 PLACES ±				CHK'D: TKUMARKC 2019/10/24					
3 PLACES ±				APPR: JCHIANG 2019/10/24				PRODUCT CUSTOMER DRAWING	
2 PLACES ± 0.13				INITIAL REVISION:				DOCUMENT NUMBER	
1 PLACE ± 0.25				DRWN: TKUMARKC 2018/09/27				2048238001	
0 PLACES ±				APPR: RCHEN08 2018/12/04				PSD ASY C2	
DRAFT WHERE APPLICABLE MUST REMAIN WITHIN DIMENSIONS		THIRD ANGLE PROJECTION		DRAWING		SERIES		MATERIAL NUMBER	
				C-SIZE		204823		SEE SHEET 3	
DOCUMENT STATUS		P1		RELEASE DATE		2019/10/24 11:52:29		CUSTOMER	
								SHEET NUMBER	
								6 OF 10	

BEZEL AND BOARD POSITION DIMENSIONS FOR SINGLE SIDE MOUNTING (CAGE WITH SPRING FINGER)

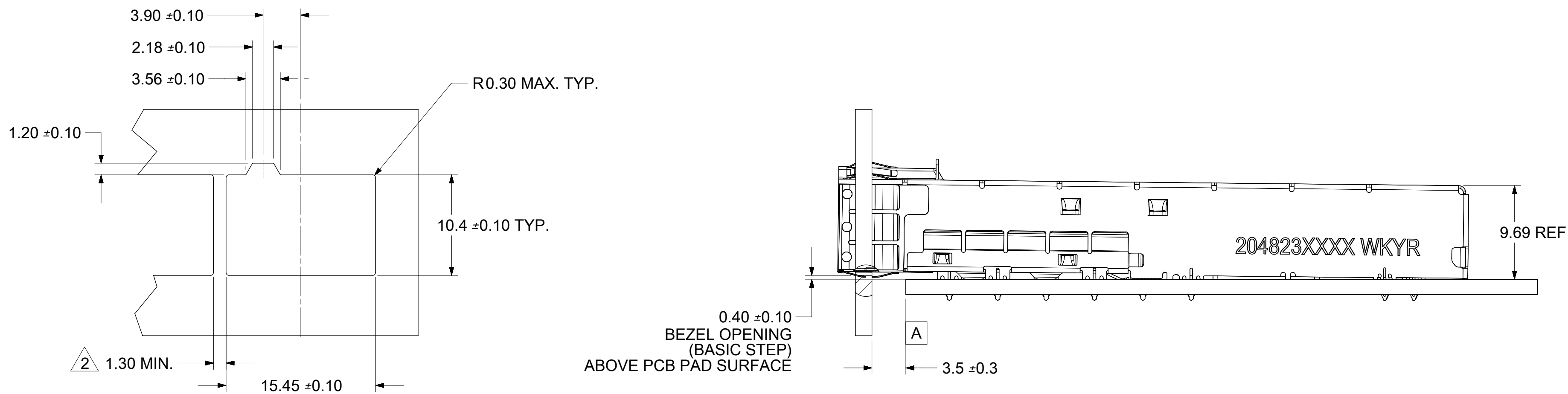

BEZEL AND BOARD POSITION DIMENSIONS FOR BELLY TO BELLY MOUNTING (CAGE WITH SPRING FINGER)

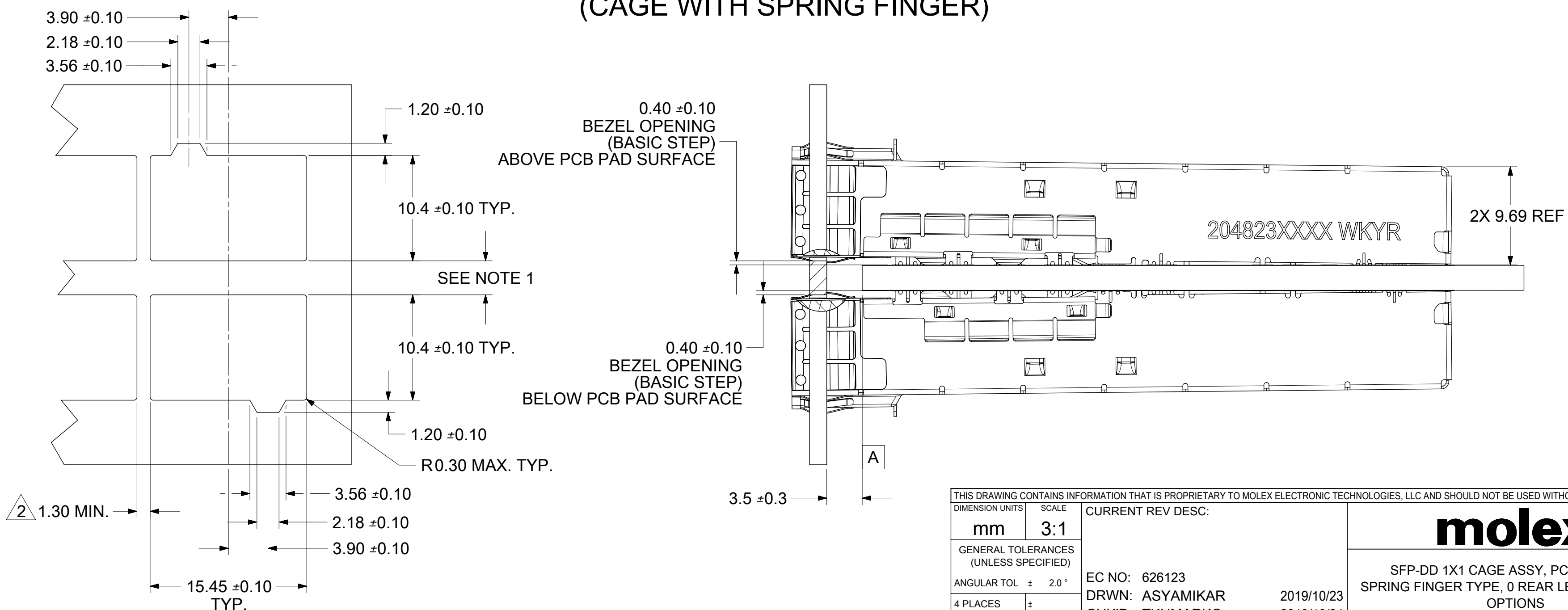

1. PCB THICKNESS VARIATION MUST BE CONSIDERED WHEN DETERMINING BEZEL OPENING AND LOCATION
- 2 THIS DIMENSION IS FOR REFERENCE ONLY. USER CAN MODIFY IT DEPENDS ON APPLICATION.
(THIS DIMENSION VARIES BASED ON DISTANCE OF "HOLE OF ADJACENT CAGE" ON PCB LAYOUT)

THIS DRAWING CONTAINS INFORMATION THAT IS PROPRIETARY TO MOLEX ELECTRONIC TECHNOLOGIES, LLC AND SHOULD NOT BE USED WITHOUT WRITTEN PERMISSION											
DIMENSION UNITS	SCALE	CURRENT REV DESC:					molex				
mm	3:1						SFP-DD 1X1 CAGE ASSY, PCI VERSION, SPRING FINGER TYPE, 0 REAR LEG, W/ HEATSINK OPTIONS				
GENERAL TOLERANCES (UNLESS SPECIFIED)		EC NO: 626123					PRODUCT CUSTOMER DRAWING				
ANGULAR TOL ± 2.0°		DRWN: ASYAMIKAR 2019/10/23									
4 PLACES ±		CHK'D: TKUMARKC 2019/10/24					DOCUMENT NUMBER: 2048238001 DOC TYPE: PSD DOC PART: ASY REVISION: C2				
3 PLACES ±		APPR: JCHIANG 2019/10/24									
2 PLACES ± 0.13		INITIAL REVISION:					MATERIAL NUMBER: SEE SHEET 3 CUSTOMER: SHEET NUMBER: 7 OF 10				
1 PLACE ± 0.25		DRWN: TKUMARKC 2018/09/27									
0 PLACES ±		APPR: RCHEN08 2018/12/04									
DRAFT WHERE APPLICABLE MUST REMAIN WITHIN DIMENSIONS		THIRD ANGLE PROJECTION		DRAWING		SERIES		MATERIAL NUMBER		CUSTOMER	
				C-SIZE		204823		SEE SHEET 3		7 OF 10	

BEZEL AND BOARD POSITION DIMENSIONS FOR SINGLE SIDE MOUNTING (CAGE WITH LIGHT PIPE)

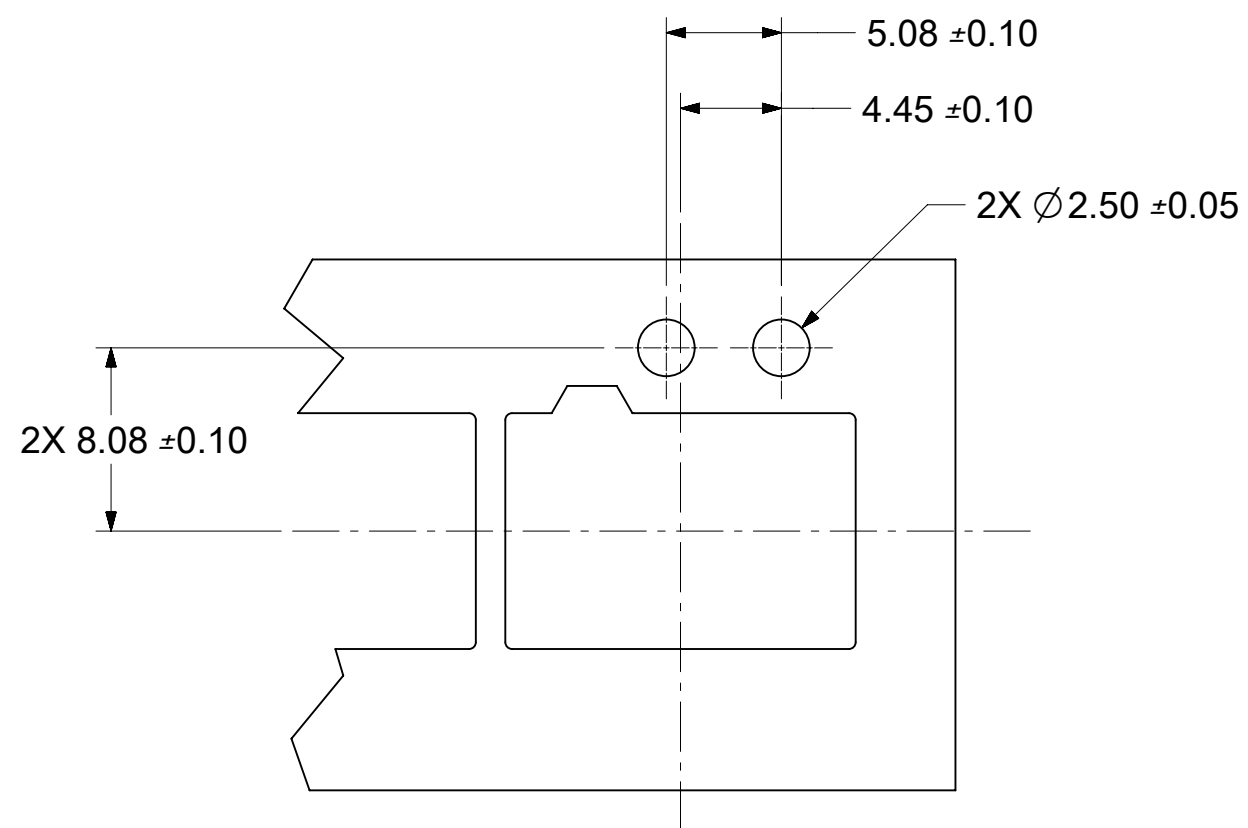
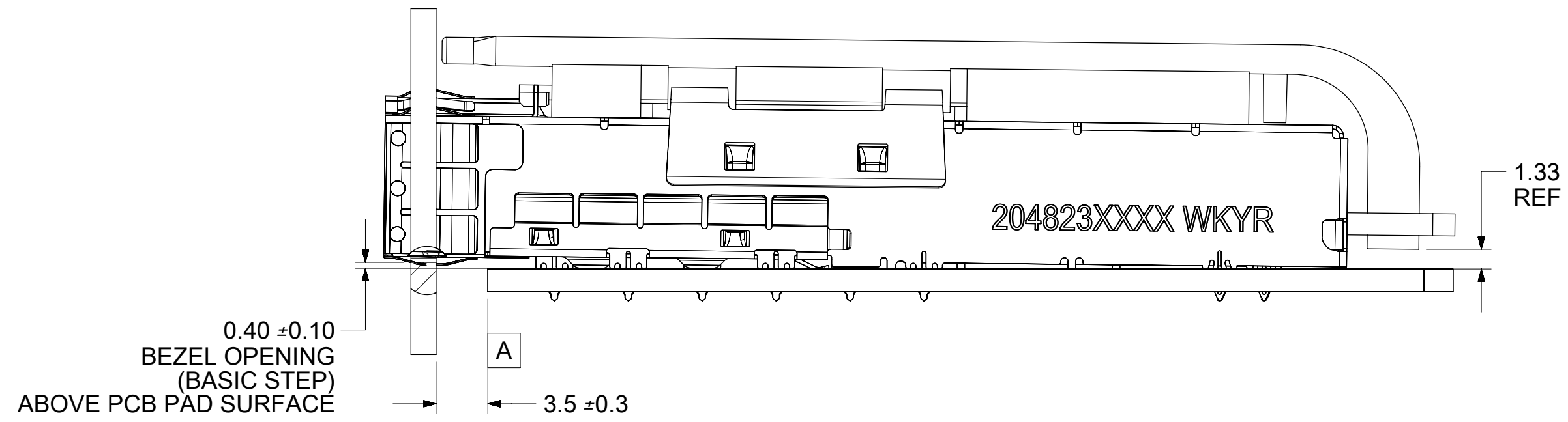

DUAL LIGHT PIPE OPTION

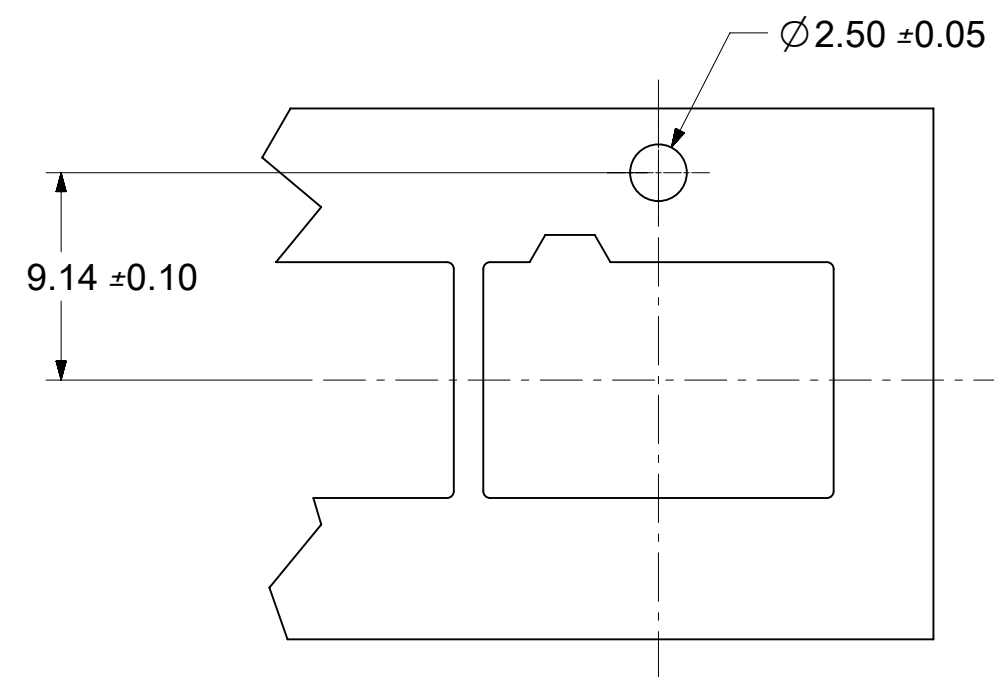

SINGLE LIGHT PIPE OPTION

THIS DRAWING CONTAINS INFORMATION THAT IS PROPRIETARY TO MOLEX ELECTRONIC TECHNOLOGIES, LLC AND SHOULD NOT BE USED WITHOUT WRITTEN PERMISSION									
DIMENSION UNITS		SCALE		CURRENT REV DESC:				molex	
mm		1:1							
GENERAL TOLERANCES (UNLESS SPECIFIED)				EC NO: 626123				SFP-DD 1X1 CAGE ASSY, PCI VERSION, SPRING FINGER TYPE, 0 REAR LEG, W/ HEATSINK OPTIONS	
ANGULAR TOL ± 2.0°				DRWN: ASYAMIKAR 2019/10/23					
4 PLACES ±				CHK'D: TKUMARKC 2019/10/24					
3 PLACES ±				APPR: JCHIANG 2019/10/24				PRODUCT CUSTOMER DRAWING	
2 PLACES ± 0.13				INITIAL REVISION:				DOCUMENT NUMBER	
1 PLACE ± 0.25				DRWN: TKUMARKC 2018/09/27				2048238001	
0 PLACES ±				APPR: RCHEN08 2018/12/04				PSD ASY C2	
DRAFT WHERE APPLICABLE MUST REMAIN WITHIN DIMENSIONS		THIRD ANGLE PROJECTION		DRAWING		SERIES		MATERIAL NUMBER	
				C-SIZE		204823		SEE SHEET 3	
DOCUMENT STATUS		RELEASE DATE		CUSTOMER		SHEET NUMBER		REVISION	
P1		2019/10/24 11:52:29				8 OF 10		C2	

BEZEL AND BOARD POSITION DIMENSIONS FOR BELLY TO BELLY MOUNTING (CAGE WITH LIGHT PIPE)

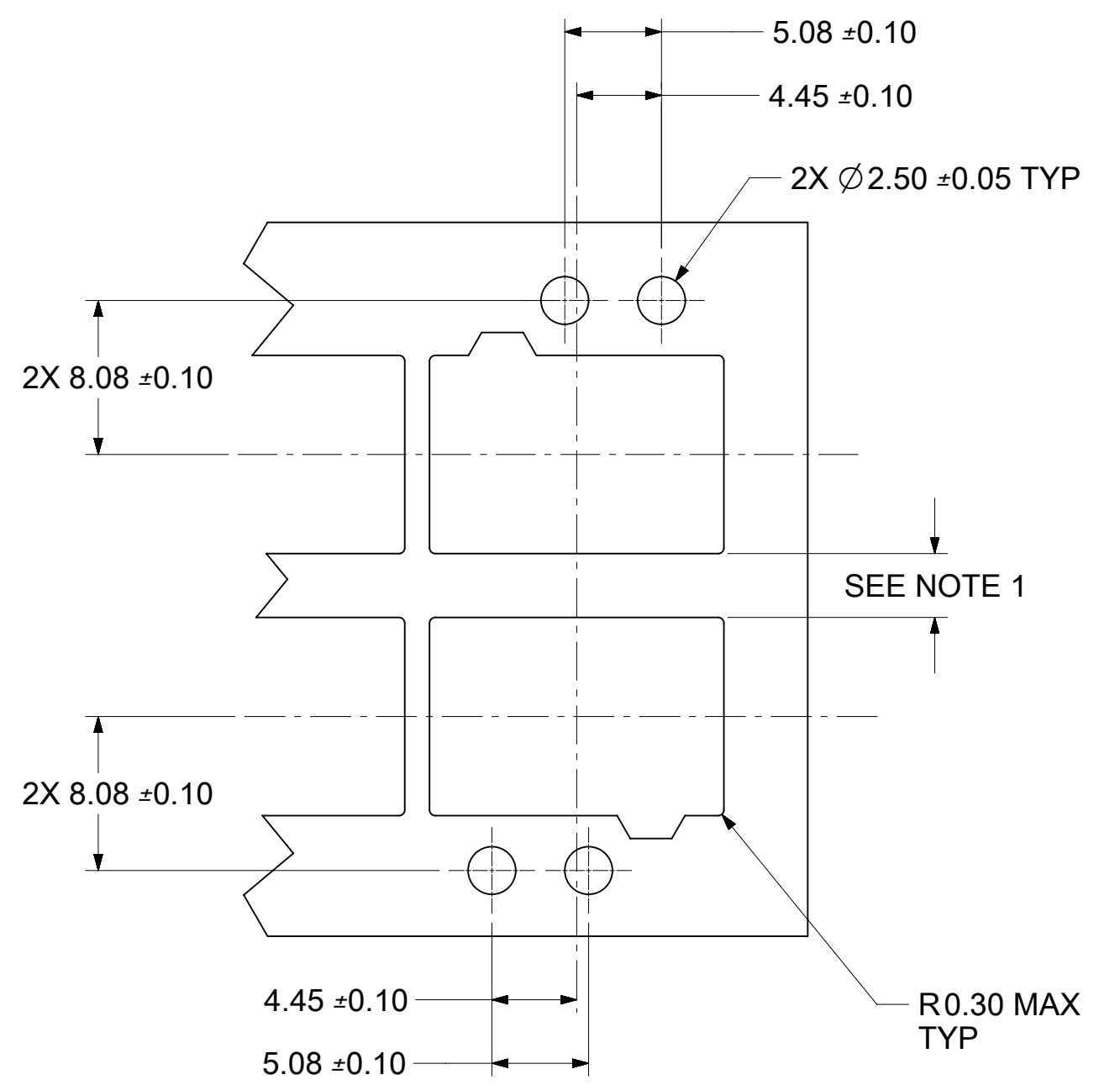
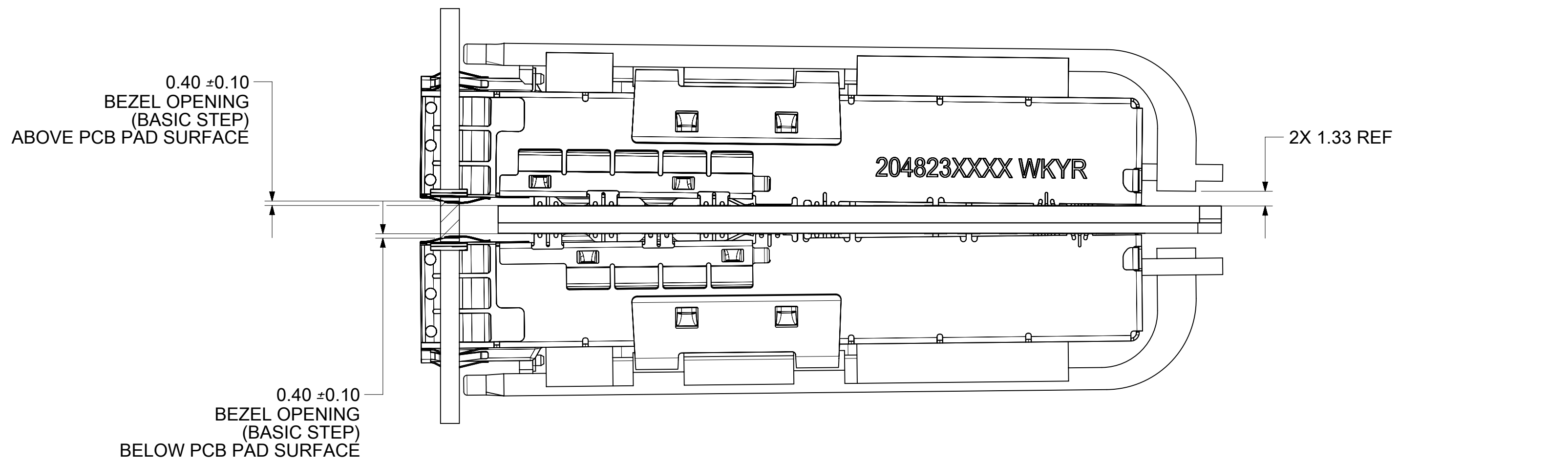

DUAL LIGHT PIPE OPTION

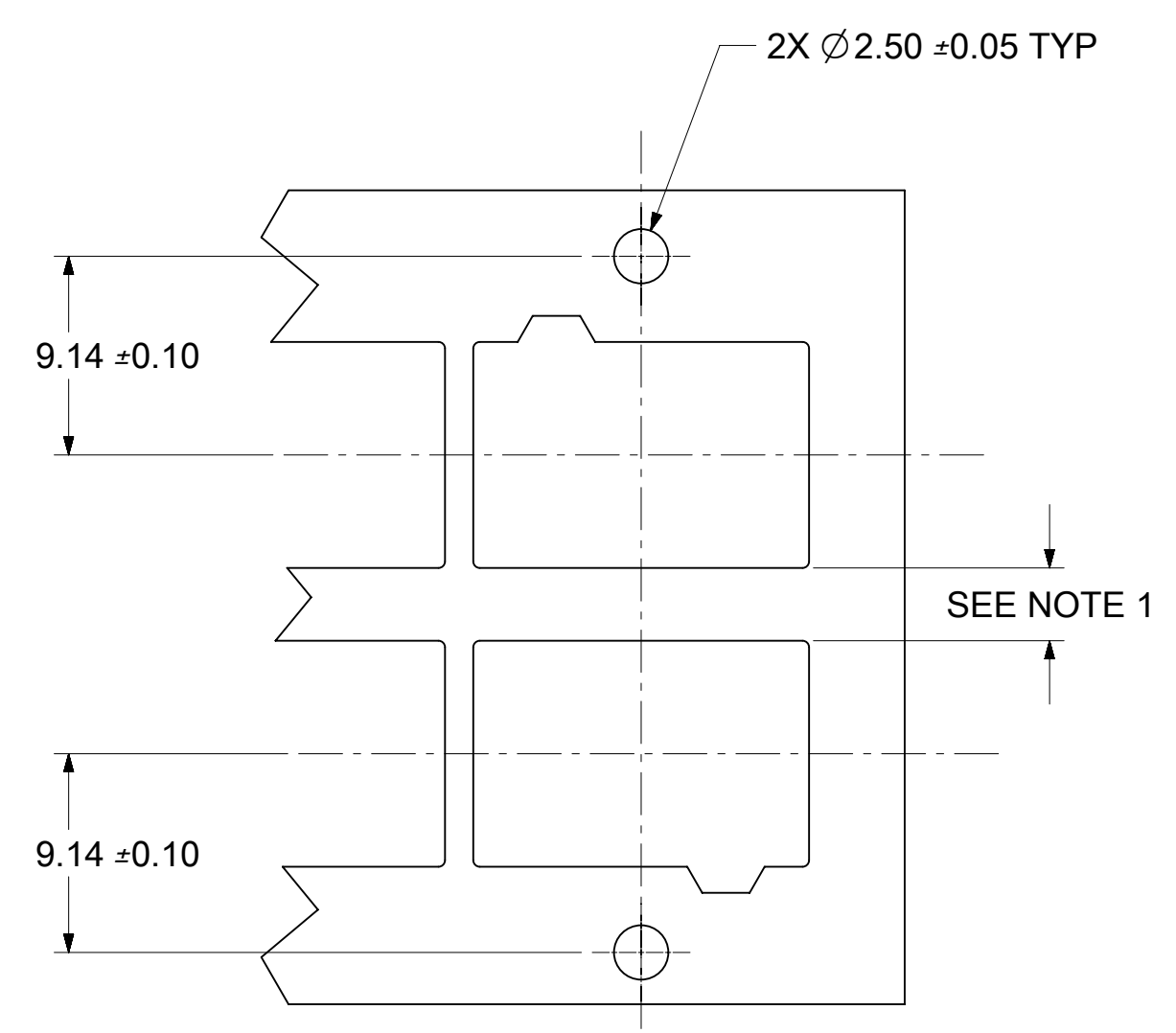

SINGLE LIGHT PIPE OPTION

NOTE:

1. PCB THICKNESS VARIATION MUST BE CONSIDERED WHEN DETERMINING BEZEL OPENING AND LOCATION

THIS DRAWING CONTAINS INFORMATION THAT IS PROPRIETARY TO MOLEX ELECTRONIC TECHNOLOGIES, LLC AND SHOULD NOT BE USED WITHOUT WRITTEN PERMISSION

DIMENSION UNITS	SCALE	CURRENT REV DESC:		molex				
mm	3:1			SFP-DD 1X1 CAGE ASSY, PCI VERSION, SPRING FINGER TYPE, 0 REAR LEG, W/ HEATSINK OPTIONS				
GENERAL TOLERANCES (UNLESS SPECIFIED)		EC NO: 626123		PRODUCT CUSTOMER DRAWING				
ANGULAR TOL ± 2.0°		DRWN: ASYAMIKAR 2019/10/23						
4 PLACES ±		CHK'D: TKUMARKC 2019/10/24						
3 PLACES ±		APPR: JCHIANG 2019/10/24		DOCUMENT NUMBER				
2 PLACES ± 0.13		INITIAL REVISION:		2048238001		DOC TYPE	DOC PART	REVISION
1 PLACE ± 0.25		DRWN: TKUMARKC 2018/09/27		PSD ASY C2				
0 PLACES ±		APPR: RCHEN08 2018/12/04		MATERIAL NUMBER		CUSTOMER		SHEET NUMBER
DRAFT WHERE APPLICABLE MUST REMAIN WITHIN DIMENSIONS		THIRD ANGLE PROJECTION	DRAWING	SERIES	SEE SHEET 3		9 OF 10	
			C-SIZE	204823				

REV	DATE	DESCRIPTIONS
A	2018/12/03	INITIAL RELEASE
B	2019/01/14	SHEET 1 : B4 : DATE CODE NATE IS UPDATED WITH LASER MARKING OPTION. SHEET 6: ADDED A SHEET TO SHOW "KEEP OUT AREA FOR INSERTION/EXTRACTION TOOL".
C	2019/03/25	SHEET 1 : DELETED 2048238003 P/N VIEWS AND 2048238201 VIEWS ARE SHOWN B2 : ADDED P/N TABLE. C8: ADDED DIMENSION 14.80 MAX. C8: ADDED DIMENSION DIM "A" D5: ADDED DIMENSION 72.35 D5: ADDED DIMENSION 64.45 SHEET 3: C11 : ADDED P/N 2048238101 C07 : ADDED P/N 2048238201 SHEET 4: F04: ADDED DIMENSION \varnothing 1.55 REF. SHEET 8 AND 9 ADDED TO SHOW LIGHT PIPE OPTION CAGE.
C1	2019/04/26	SHEET 2 : B1 : UPDATED DIM "A" FOR BOTH SINGLE AND DUAL LIGHT PIPE OPTION. SHEET 4 : G8: DIA SYMBOL ADDED IN TOLERANCE ZONE B9 : LED LOCATIONS SHOWN SHEET 5 : G7: DIA SYMBOL ADDED IN TOLERANCE ZONE A9 : LED LOCATIONS SHOWN SHEET 6 : B7: LED LOCATIONS SHOWN
C2	2019/10/23	FOR BETTER VISIBILITY, THE LOCATION OF DATE CODE TEXT ON THE CAGE COVER ADJUSTED IN SHEET 1, SHEET 2, SHEET 3, SHEET 7, SHEET 8 AND SHEET 9.

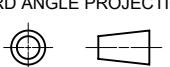
THIS DRAWING CONTAINS INFORMATION THAT IS PROPRIETARY TO MOLEX ELECTRONIC TECHNOLOGIES, LLC AND SHOULD NOT BE USED WITHOUT WRITTEN PERMISSION									
DIMENSION UNITS	SCALE	CURRENT REV DESC:							
mm	3:1								
GENERAL TOLERANCES (UNLESS SPECIFIED)		EC NO: 626123			SFP-DD 1X1 CAGE ASSY, PCI VERSION, SPRING FINGER TYPE, 0 REAR LEG, W/ HEATSINK OPTIONS				
ANGULAR TOL	± 2.0°	DRWN: ASYAMIKAR 2019/10/23							
4 PLACES	±	CHK'D: TKUMARKC 2019/10/24			PRODUCT CUSTOMER DRAWING				
3 PLACES	±	APPR: JCHIANG 2019/10/24							
2 PLACES	± 0.13	INITIAL REVISION:			DOCUMENT NUMBER: 2048238001 DOC TYPE: PSD DOC PART: ASY REVISION: C2				
1 PLACE	± 0.25	DRWN: TKUMARKC 2018/09/27							
0 PLACES	±	APPR: RCHEN08 2018/12/04			MATERIAL NUMBER: SEE SHEET 3 CUSTOMER:				
DRAFT WHERE APPLICABLE MUST REMAIN WITHIN DIMENSIONS		THIRD ANGLE PROJECTION	DRAWING	SERIES					
			C-SIZE	204823	10 OF 10				