

Demonstration System EPC9506 Quick Start Guide

*ZVS Class-D Wireless Power Amplifier
Demo Board using EPC2014*



DESCRIPTION

The EPC9506 is a high efficiency, Zero Voltage Switching (ZVS), Class-D Wireless Power amplifier demonstration board operating at 6.78 MHz (Lowest ISM band). The purpose of this demonstration system is to simplify the evaluation process of wireless power technology using eGaN® FETs by including all the critical components on a single board that can be easily connected into an existing system.

The amplifier board features the EPC2014 (40 V rated - EPC9506) enhancement mode field effect transistor (FET) in an optional half-bridge topology (single ended configuration) or default full-bridge topology (differential configuration), and includes the gate driver/s and oscillator that ensures operation of the system at 6.78 MHz. The amplifier board can also be operated using an external oscillator.

The amplifier board is equipped with a pre-regulator that limits the current of the supply to the amplifier. As the amplifier draws more current, which can be due to the absence of a device coil, the pre-regulator will reduce the voltage being supplied to the amplifier that will ensure a safe operating point. The pre-regulator also monitors the temperature of the main amplifier FETs and will reduce current if the temperature exceeds 85°C. The pre-regulator can be bypassed to allow testing with custom control hardware. The board further allows easy access to critical measurement nodes that allow accurate power measurement instrumentation hookup. A simplified diagram of the amplifier board is given in Figure 1.

For more information on the EPC2014 eGaN FET please refer to the data-sheet available from EPC at www.epc-co.com. The data-sheet should be read in conjunction with this quick start guide.

Table 1: Performance Summary (TA = 25 °C) EPC9506

Symbol	Parameter	Conditions	Min	Max	Units
V _{DD}	Control Supply Input Range		7	12	V
V _{IN}	Bus Input Voltage Range – Pre-Regulator mode		8	32	V
V _{IN}	Bus Input Voltage Range – Bypass mode		0	32	V
V _{OUT}	Switch Node Output Voltage			V _{IN}	V
I _{OUT}	Switch Node Output Current (each)			10*	A
V _{extosc}	External Oscillator Input Threshold	Input ‘Low’	-0.3	0.8	V
		Input ‘High’	2.4	5	V
V _{Pre_Disable}	Pre-regulator Disable Voltage Range	Open Drain/Collector	-0.3	5.5	V
I _{Pre_Disable}	Pre-regulator Disable Current	Open Drain/Collector	-1	1	mA
V _{Osc_Disable}	Oscillator Disable Voltage Range	Open Drain/Collector	-0.3	5	V
I _{Osc_Disable}	Oscillator Disable Current	Open Drain/Collector	-25	25	mA

* Assumes inductive load, maximum current depends on die temperature – actual maximum current will be subject to switching frequency, bus voltage and thermal.



EPC9506 Amplifier Board Photo

DESCRIPTION

The Amplifier Board (EPC9506)

Figure 1 shows a diagram of the EPC9506 ZVS class D amplifier with pre-regulator. The pre-regulator is set to a specified DC output current limit (up to 1.5 A) by adjusting P49 and operates from 8 V through 36 V input. The output voltage of the pre-regulator is limited to approximately 2 V below the input voltage. The pre-regulator can be bypassed by moving the jumper (JP60) over from the right 2 pins to the left 2 pins. To measure the current the amplifier is drawing, an ammeter can be inserted in place of the jumper (JP60) in the location based on the operating mode (pre-regulator or bypass).

The amplifier comes with its own oscillator that is pre-programmed to 6.78 MHz \pm 678 Hz. It can be disabled by placing a jumper into J70 or can be externally shutdown using an externally controlled open collector / drain transistor on the terminals of J70 (note which is the ground connection). The switch needs to be capable of sinking at least 25 mA. An external oscillator can be used instead of the internal oscillator when connected to J71 (note which is the ground connection) and the jumper (JP70) is moved from the right 2 pins to the left 2 pins.

The pre-regulator can also be disabled in the same manner as the oscillator using J51. The pre-regulator can be bypassed, to increase the operating voltage (with no current or thermal protection) to the amplifier or to use an external regulator, by moving the jumper JP60 from the right 2 pins to the left 2 pins. Jumper JP60 can also be used to connect an ammeter to measure the current drawn by the amplifier (make sure the ammeter connects to the pins that correspond to the mode of operation either bypass or pre-regulator).

Single Ended Operation

The amplifier can be configured for single ended operation where only devices Q1 and Q2 are used. In this mode only L_{ZVS1} and C_{ZVS} are used to establish ZVS operation. If Q11 and Q12 are populated, then the following changes need to be made to the board:

- 1) Remove R76 and R77
- 2) Short out C46 and C47
- 3) Short the connection of JMP1 (back side of the board)
- 4) Remove L_{ZVS12} (if populated)
- 5) Add L_{ZVS1} (270 nH)
- 6) Check that C_{ZVS1} is populated, if not then install.
- 7) R74 and R75 may need to be adjusted for the new operating condition to achieve maximum efficiency (see section on ZVS timing adjustment).

ZVS Timing Adjustment

Setting the correct time to establish ZVS transitions is critical to achieving high efficiency with the EPC9506 amplifier. This can be done by selecting the values for R74 and R75 respectively. This procedure is best performed using potentiometer P74 and P75 installed that is used to determine the fixed resistor values. The procedure is the same for both single ended and differential mode of operation. The timing MUST initially be set WITHOUT the source coil connected to the amplifier. The timing diagrams are given in Figure 4 and should be referenced when following this procedure. Only perform these steps if changes have been made to the board as it is shipped preset. The steps are:

1. Remove the jumper in JP60 and insert it into J51 to place the EPC9506 amplifier in bypass mode. With power off connect the main input power supply (+) bus to the center pin of JP60 (pin 2) and the ground of the main power to the ground (-) connection of J50 $-V_{IN}$.
2. With power off, connect the control input power supply bus to $+V_{DD}$ (J90). Note the polarity of the supply connector.
3. Connect a LOW capacitance oscilloscope probe to the probe-hole J2 and lean against the ground post as shown in Figure 2.
4. Turn on the control supply – make sure the supply is between 7V and 12 V range (7.5 V is recommended).
5. Turn on the main supply voltage to the required predominant operating value (such as 24 V but NEVER exceed the absolute maximum voltage of 32 V).
6. While observing the oscilloscope adjust P74 for the rising edge of the waveform so achieve the green waveform of figure 4. Repeat for the falling edge of the waveform by adjusting P75.
7. Check that the setting remains optimal with a source coil attached. In this case it is important that the source coil is TUNED to resonance WITH an applicable load. Theoretically the settings should remain unchanged. Adjust if necessary.
8. Replace the potentiometers with fixed value resistors. Configure the EPC9506 amplifier back to normal operation by removing the power connections to J50 and JP60, removing the jumper in J51 and inserting it back into JP60 (right 2 pins 2 & 3).

Differential Operation

The amplifier can be configured for differential operation where all the devices are used; Q1, Q2, Q11 and Q12. In this mode either L_{ZVS1} , L_{ZVS11} and C_{ZVS} or L_{ZVS12} only is used to establish ZVS operation.

Determining Component Values for L_{ZVS}

The ZVS tank circuit is not operated at resonance, and only provides the necessary negative device current for self-commutation of the output voltage at turn off. The capacitance C_{ZVS} is chosen to have a very small ripple voltage component and is typically around 1 μ F. The amplifier supply voltage, switch-node transition time will determine the value of inductance for L_{ZVSx} which needs to be sufficient to maintain ZVS operation over the DC device load resistance range and coupling between the device and source coil range and can be calculated using the following equation:

$$L_{ZVS} = \frac{\Delta t_{vt}}{8 \cdot f_{sw} \cdot C_{OSSQ}} \quad (1)$$

Where: Δt_{vt} = Voltage transition time [s]
 f_{sw} = Operating frequency [Hz]
 C_{OSSQ} = Charge equivalent device output capacitance [F].

Note that the amplifier supply voltage V_{AMP} is absent from the equation as it is accounted for by the voltage transition time. The charge equivalent capacitance can be determined using the following equation:

$$C_{OSSQ} = \frac{1}{V_{AMP}} \cdot \int_0^{V_{AMP}} C_{OSS}(v) \cdot dv \quad (2)$$

To add additional immunity margin for shifts in coil impedance, the value of L_{ZVS} can be decreased to increase the current at turn off of the devices (which will increase device losses). Typical voltage transition times range from 2 ns through 12 ns. For the differential case the voltage and charge (C_{OSSQ}) are doubled.

QUICK START PROCEDURE

The EPC9506 amplifier board is easy to set up and evaluate the performance of the eGaN FET in a wireless power transfer application.

The EPC9506 can be operated using any one of two alternative methods:

- a. Using the pre-regulator
- b. Bypassing the pre-regulator

a. Operation using the pre-regulator

The pre-regulator is used to supply power to the amplifier in this mode and will limit the DC current to the amplifier based on the setting. The pre-regulator also monitors the temperature of the amplifier and will limit the current in the event the temperature exceeds 85°C.

1. Make sure the entire system is fully assembled prior to making electrical connections and make sure jumper (JP60 is set to pre-regulator – right 2 pins).
2. With power **off**, connect the **main** input power supply bus to +V_{IN} (J50). Note the polarity of the supply connector.
3. With power **off**, connect the **control** input power supply bus to +V_{DD} (J90). Note the polarity of the supply connector.
4. Select and connect an applicable load resistance to the device board.
5. Make sure all instrumentation is connected to the system.
6. Turn on the control supply – make sure the supply is between 7 V and 12 V (7.5 V is recommended).
7. Turn on the main supply voltage to the required value (it is recommended to start at 8 V and do not exceed the absolute maximum voltage of 32 V).
8. Once operation has been confirmed, adjust the main supply voltage within the operating range and observe the output voltage, efficiency and other parameters on both the amplifier and device boards.
9. For shutdown, please follow steps in the reverse order. Start by reducing the main supply voltage to 0 V followed by steps 6 through 2.

b. Operation bypassing the pre-regulator

In this mode, the pre-regulator is bypassed and the main power is connected directly to the amplifier. This allows the amplifier to be operated using an external regulator.

In this mode there is no current or thermal protection for the eGaN FETs.

1. Make sure the entire system is fully assembled prior to making electrical connections and remove the jumper JP60. Never connect the main power positive (+) to J50 when operating in bypass mode.
2. With power **off**, connect the **main** input power supply ground to the ground terminal of J50 (-) and the positive (+) to the center pin of JP60.

3. With power **off**, connect the **control** input power supply bus to +V_{DD} (J90). Note the polarity of the supply connector.
4. Select and connect an applicable load resistance to the device board.
5. Make sure all instrumentation is connected to the system.
6. Turn on the control supply – make sure the supply is between 7 V and 12 V range (7.5 V is recommended).
7. Turn on the main supply voltage to the required value (it is recommended to start at 2 V and do not exceed the absolute maximum voltage of 32 V).
8. Once operation has been confirmed, adjust the main supply voltage within the operating range and observe the output voltage, efficiency and other parameters on both the amplifier and device boards. See Pre-Cautions when operating in the bypass mode
9. For shutdown, please follow steps in the reverse order. Start by reducing the main supply voltage to 0 V followed by steps 6 through 2.

NOTE. When measuring the high frequency content switch-node (Source Coil Voltage), care must be taken to avoid long ground leads. An oscilloscope probe connection (preferred method) has been built into the board to simplify the measurement of the Source Coil Voltage (J2 and J3 as shown in Figure 3).

THERMAL CONSIDERATIONS

The EPC9506 demonstration system showcases the EPC2014 eGaN FET in a wireless energy transfer application. Although the electrical performance surpasses that of traditional silicon devices, their relatively smaller size does magnify the thermal management requirements. The operator must observe the temperature of the gate driver and eGaN FETs to ensure that both are operating within the thermal limits as per the datasheets.

NOTE. The EPC9506 demonstration system has limited current and thermal protection only when operating off the Pre-Regulator. When bypassing the pre-regulator there is no current or thermal protection on board and care must be exercised not to over-current or over-temperature the devices. Wide coil coupling and load range variations can lead to increased losses in the devices.

Pre-Cautions

The EPC9506 demonstration system has no controller or enhanced protections systems and therefore should be operated with caution. Some specific precautions are:

1. Please contact EPC at info@epc-co.com should the tuning of the coil be required to change to suit specific conditions so that it can be correctly adjusted for use with the ZVS Class-D amplifier.
2. There is no heat-sink on the devices and during experimental evaluation it is possible present conditions to the amplifier that may cause the devices to overheat. Always check operating conditions and monitor the temperature of the EPC devices using an IR camera.

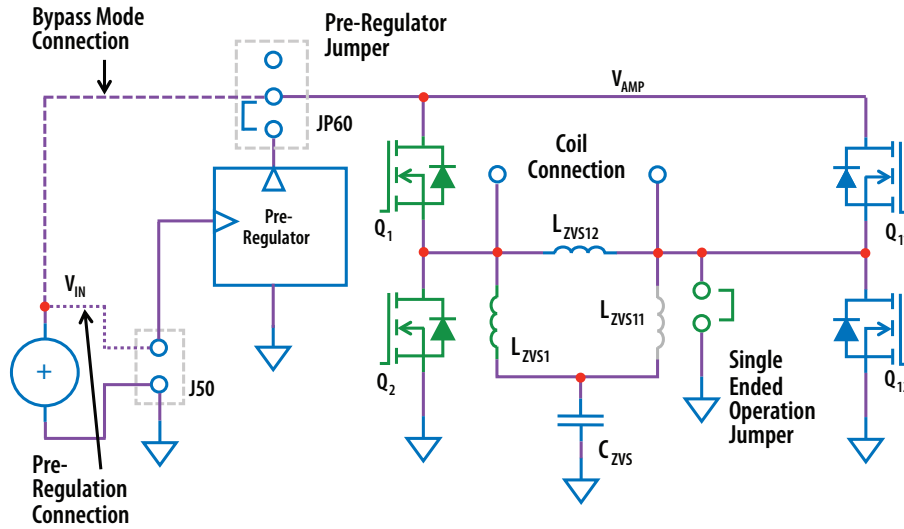

Figure 1: Diagram of EPC9506 Amplifier Board

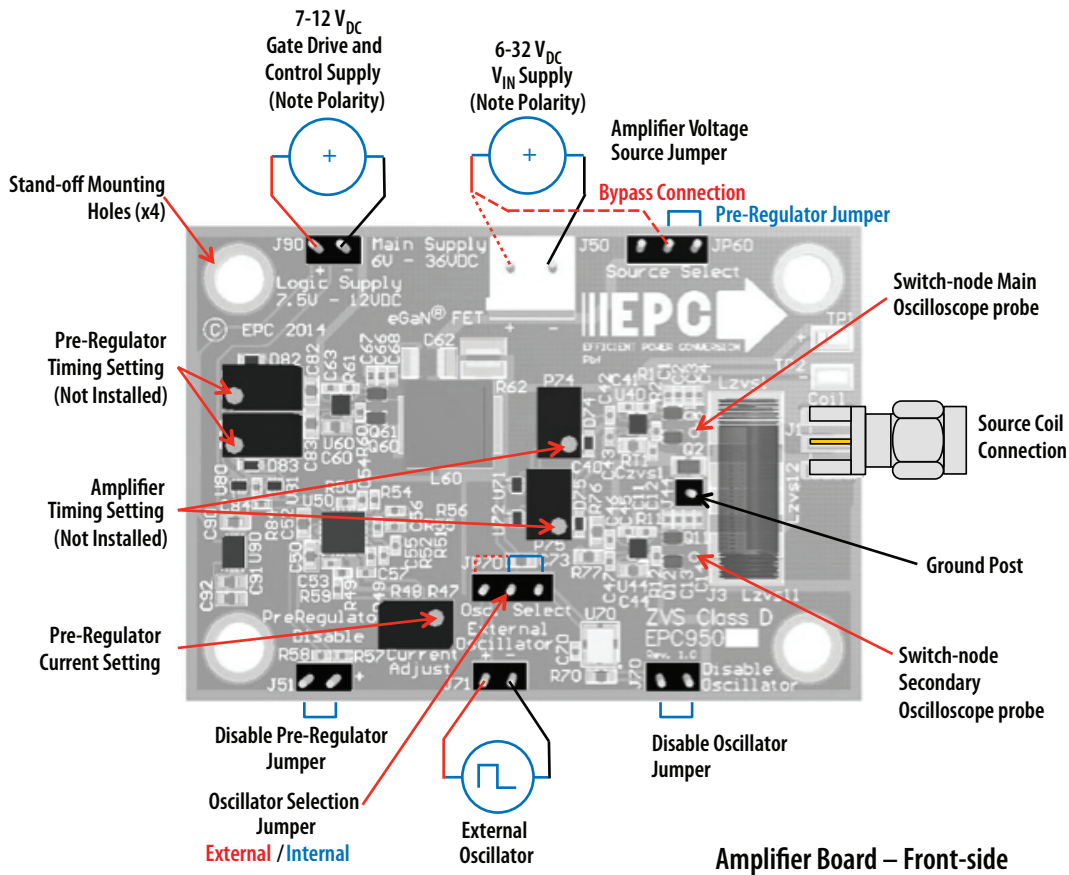

Figure 2: Proper Connection and Measurement Setup for the Amplifier Board

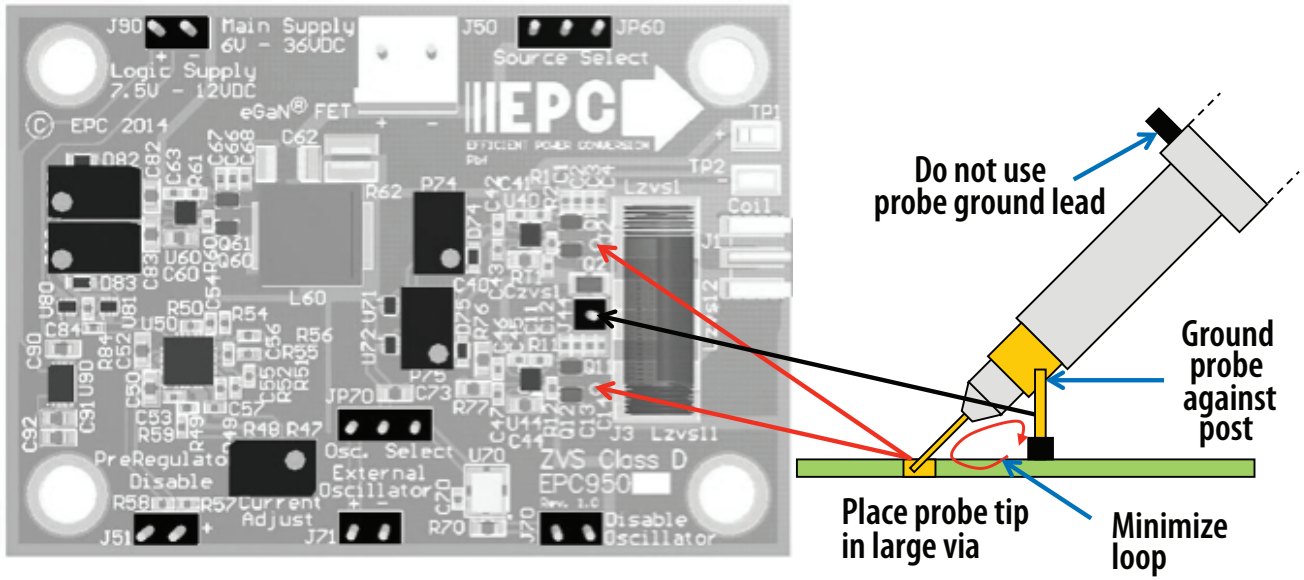

Figure 3: Proper Measurement of the Switch Nodes Using the Hole and Ground Post

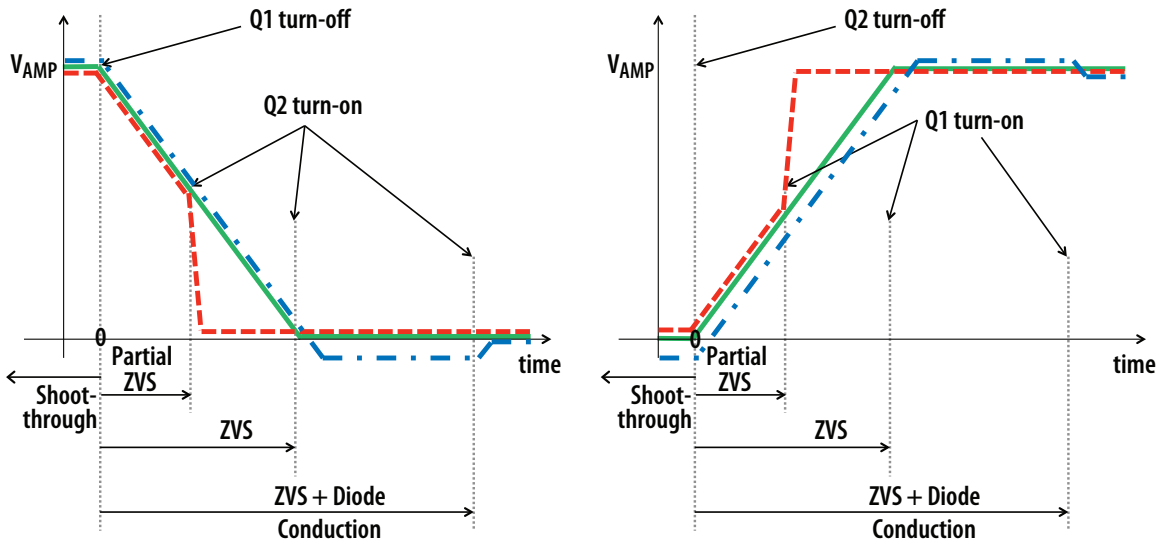

Figure 4: ZVS Timing Diagrams

Table 3: Bill of Materials - Amplifier Board

Item	Qty	Reference	Part Description	Manufacturer	Part #
1	12	C1, C2, C3, C4, C11, C12, C13, C14 C55, C66, C67, C68	10 nF, 100 V	TDK	C1005X7S2A103K050BB
2	7	C5, C6, C15, C16, C62, C64, C65	4.7 μ F, 50 V	Taiyo Yuden	UMK325BJ475MM-T
3	4	C40, C44 C52, C60	4.7 μ F, 16 V	TDK	C1608X5R1C475K
4	2	C41, C45	22 nF, 25 V	TDK	C1005X7R1E223K050BB
5	5	C42, C43, C46, C47 C84	47 pF, 50 V	Yageo	CC0402JRNPO9BN470
6	1	C50	1 μ F, 50 V	Taiyo Yuden	UMK107AB7105KA-T
7	2	C53, C54	2.2 nF, 50 V	Yageo	CC0402KRX7R9BB222
8	1	C56	1 nF, 50 V	Yageo	CC0402KRX7R9BB102
9	3	C57, C63, C70	100 nF, 25 V	TDK	C1005X7R1E104K050BB
10	4	C71, C72, C80, C81	100 nF, 25 V	TDK	C1608X7R1E104K
11	1	C73	DNP, 100 pF, 25 V	Generic	Generic
12	2	C82, C83	100 pF, 25 V	TDK	C1608COG1H101J080AA
13	3	C90, C91, C92	1 μ F, 25 V	TDK	C1608X7R1E105K
14	1	Czvs1	DNP 1 μ F, 50 V	Taiyo Yuden	C2012X7R1H105K125AB
15	4	D74, D75, D82, D83	40 V, 30 mA	Diodes Inc.	SDM03U40
16	1	J1	SMA Board Edge	Linx	CONREVSMA013.062
17	2	J44, J61	.1" Male Vert.	Tyco	4-103185-0-01
18	1	J50	.156" Male Vert.	Würth	645002114822
19	4	J51, J70, J71, J90	.1" Male Vert.	Würth	61300311121
20	1	JMP1	DNP	—	—
21	2	JP60, JP70	.1" Male Vert.	Tyco	4-103185-0-03
22	1	L60	10 μ H	Würth	744314101
23	2	Lzvs1, Lzvs11	DNP, 270 nH	CoilCraft	22225Q-271JEB
24	1	Lzvs12	500 nH	CoilCraft	29295Q-501JEB
25	1	P49	DNP, 10k Ω	Murata	PV37Y103C01B00
26	4	P74, P75, P82, P83	DNP, 1k Ω	Murata	PV37Y102C01B00
27	6	Q1, Q2, Q11, Q12, Q60, Q61	40 V, 10 A, 16 m Ω	EPC	EPC2014
28	6	R1, R2, R11, R12, R60, R61	2.2 Ω	Yageo	RC0402JR-072R2L
29	1	R47	6.04k Ω	Panasonic	ERJ-2RKF6041X
30	1	R48	2.74k Ω	Panasonic	ERJ-2RKF2741X
31	1	R49	3.3k Ω	Panasonic	ERJ-2RKF3301X
32	1	R50	40.2k Ω	Yageo	RC0402FR-0740K2L
33	1	R51	280k Ω	Panasonic	ERJ-2RKF2803X
34	1	R52	10k Ω	Yageo	RC0402FR-0710KL
35	1	R54	15k Ω	Yageo	RC0402JR-0715KL
36	3	R55, R56, R84	10 Ω	Yageo	RC0402FR-0710RL
37	1	R57	374k Ω	Panasonic	ERJ-2RKF3743X
38	1	R58	124k Ω	Panasonic	ERJ-2RKF1243X
39	1	R59	45.3k Ω	Panasonic	ERJ-2RKF4532X
40	1	R62	24 m Ω , 1 W	Susumu	PRL1632-R024-F-T1
41	1	R70	47k Ω	Stackpole	RMCF0603JT47K0
42	1	R73	10k Ω	Yageo	RC0603JR-0710KL
43	1	R74	100 Ω	Panasonic	ERJ-3EKF1000V
44	1	R75	124 Ω	Panasonic	ERJ-3EKF1240V
45	2	R76, R77	0 Ω	Yageo	RC0603JR-070RL

(continued on next page)

Table 3: Bill of Materials - Amplifier Board (continued)

Item	Qty	Reference	Part Description	Manufacturer	Part #
46	1	R82	31.6 Ω	Panasonic	ERJ-3EKF31R6V
47	1	R83	191 Ω	Panasonic	ERJ-3EKF1910V
48	1	RT1	470k Ω at 25°C	Murata	NCP15WM474E03RC
49	2	TP1, TP2	SMD probe loop	Keystone	5015
50	3	U40, U44, U60	100 V eGaN Driver	Texas Instruments	LM5113TM
51	1	U50	Step Down Controller	Linear Technologies	LT3741EUF#PBF
52	1	U70	Programmable Oscillator – 6.78 MHz	EPSON	SG-8002CE
53	2	U71, U80	2 In AND	Fairchild	NC7SZ08L6X
54	2	U72, U81	2 In NAND	Fairchild	NC7SZ00L6X
55	1	U90	5.0 V, 250 mA, DFN	Microchip	MCP1703T-5002E/MC
56	2	JPR1 (JP60 right), JPR2 (JP70 right)	.1" jumper	TE Connectivity	382811-8

EPC would like to acknowledge Würth Electronics (www.we-online.com/web/en/wuerth_elektronik/start.php) for their support of this project.

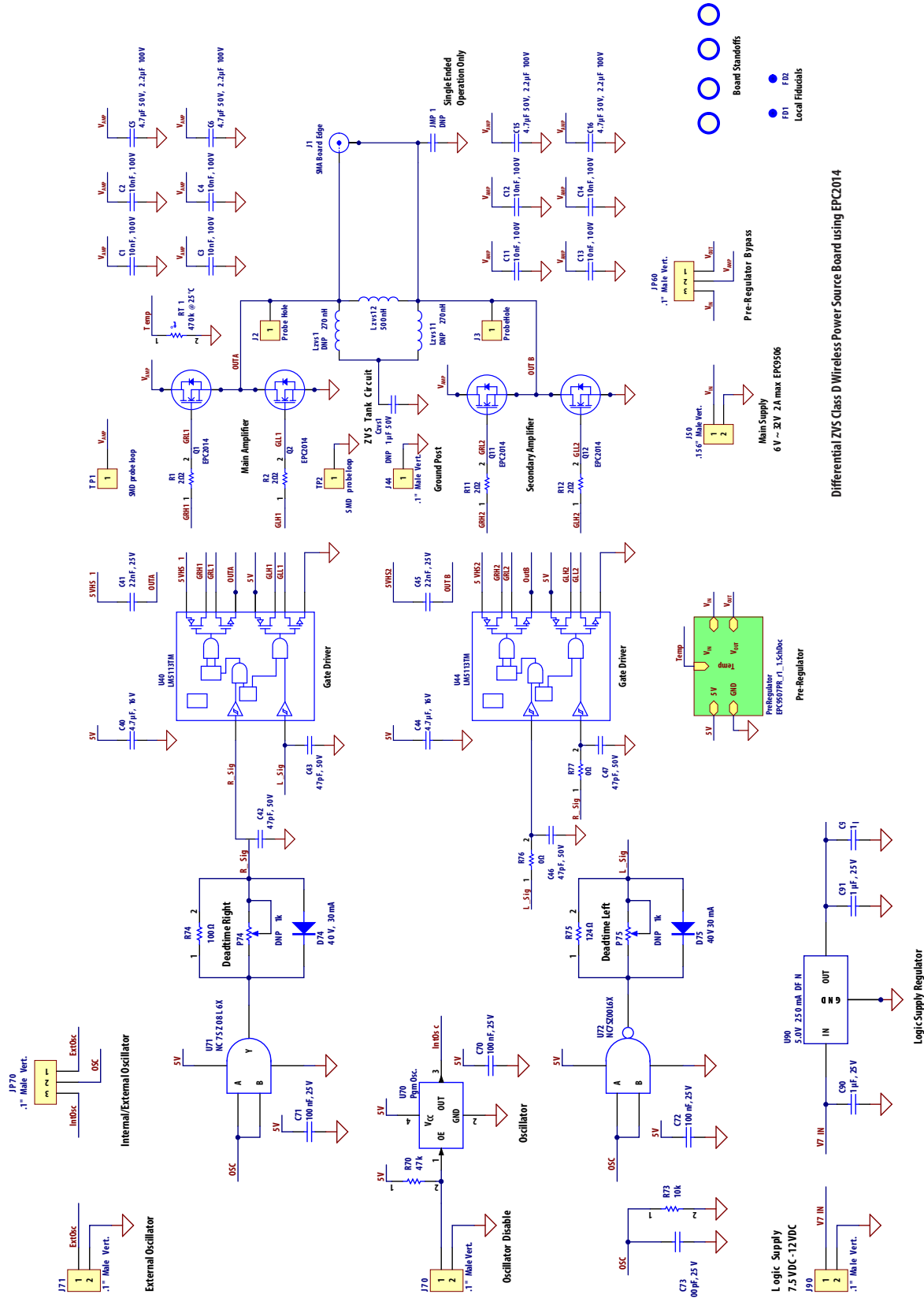

Differential ZVS Class D Wireless Power Source Board using EPC2014

Figure 5: EPC9506 Source Board Amplifier Schematic

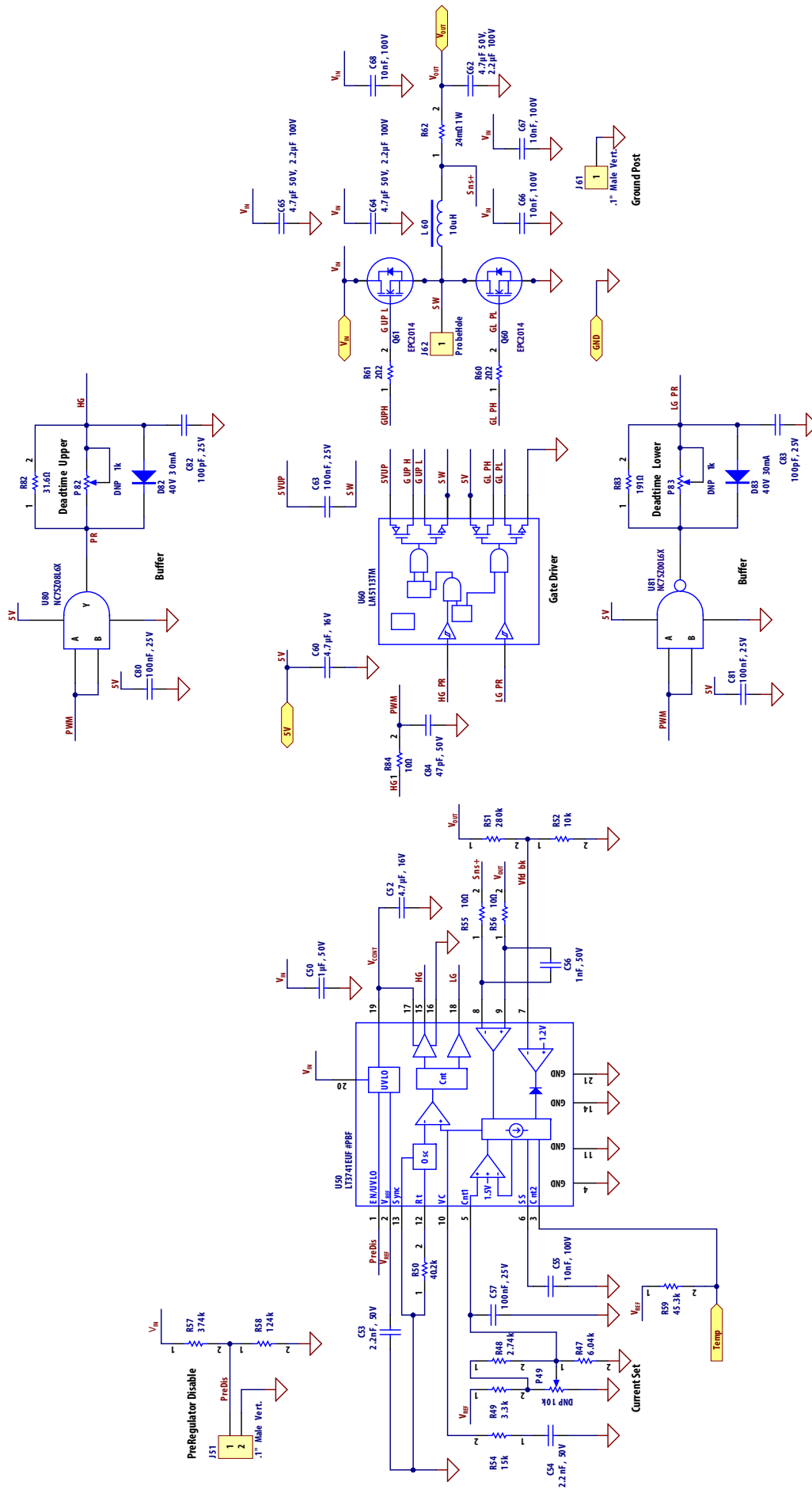

Figure 6: EPC9506 -Source Board Pre-Regulator Schematic

For More Information:

Please contact info@epc-co.com
or your local sales representative

Visit our website:
www.epc-co.com

Sign-up to receive
EPC updates at
bit.ly/EPCupdates
or text "EPC" to 22828



EPC Products are distributed through Digi-Key.

www.digikey.com

Demonstration Board Notification

The EPC9506 board is intended for product evaluation purposes only and is not intended for commercial use. As an evaluation tool, it is not designed for compliance with the European Union directive on electromagnetic compatibility or any other such directives or regulations. As board builds are at times subject to product availability, it is possible that boards may contain components or assembly materials that are not RoHS compliant. Efficient Power Conversion Corporation (EPC) makes no guarantee that the purchased board is 100% RoHS compliant. No Licenses are implied or granted under any patent right or other intellectual property whatsoever. EPC assumes no liability for applications assistance, customer product design, software performance, or infringement of patents or any other intellectual property rights of any kind.

EPC reserves the right at any time, without notice, to change said circuitry and specifications.