

Getting started with the X-NUCLEO-AMICAM1 analog MEMS microphone expansion board based on MP23ABS1 for STM32 Nucleo

Introduction

The X-NUCLEO-AMICAM1 expansion board allows synchronized acquisition and streaming of up to 4 microphones at a maximum sampling rate of 192 KHz.

It represents a quick and easy solution to develop microphone-based applications and start implementing audio algorithms.

The expansion board is designed around the MP23ABS1 analog MEMS microphone and is compatible with the ST morpho connector layout and with analog microphone coupon boards (e.g., STEVAL-MIC004V1).

The X-NUCLEO-AMICAM1 embeds three MP23ABS1 microphones: two connected to an external ADC and one directly routed to the STM32 embedded ADC.

The analog amplification stage is achieved thanks to ST TSV91x wide bandwidth operational amplifiers.

Figure 1. X-NUCLEO-AMICAM1 expansion board

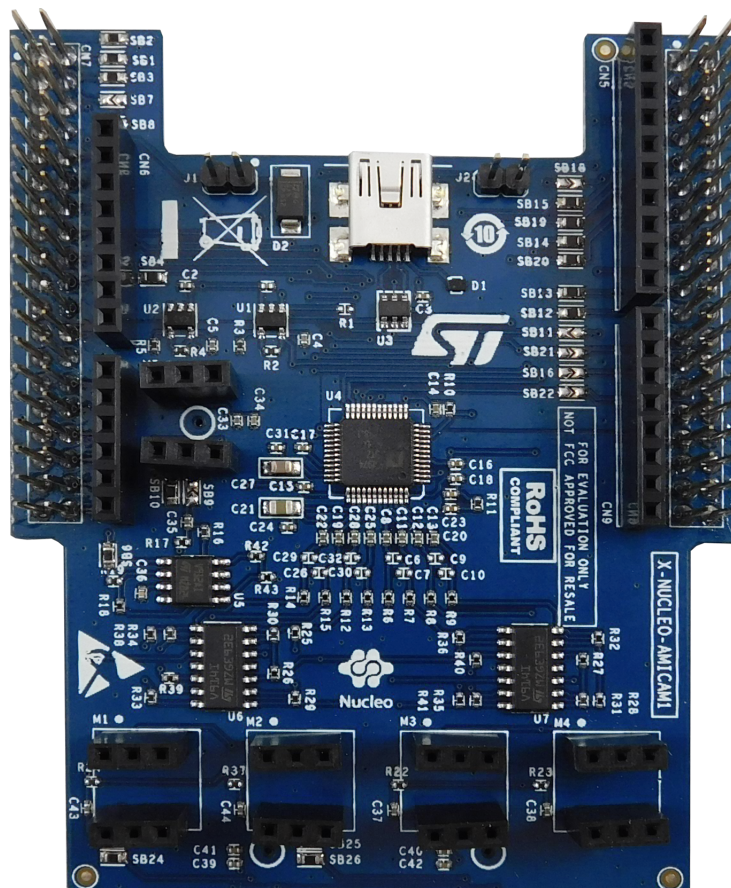

1 Overview

The **X-NUCLEO-AMICAM1** expansion board is a comprehensive tool designed for the evaluation of **MP23ABS1** analog MEMS microphones.

It features:

- 3 on-board **MP23ABS1** analog MEMS microphones
- 5 slots to plug analog microphone coupon boards (e.g., **STEVAL-MIC004V1**)
- Synchronized acquisition and streaming of up to 4 microphones
- Amplification stage based on TSV91x wide bandwidth operational amplifiers
- On-board external ADC
- Direct acquisition of a single microphone exploiting STM32 embedded ADC
- Up to 192 KHz sampling frequency
- Free comprehensive development firmware library and audio capture plus USB streaming sample application compatible with **STM32Cube**
- Compatible with **STM32 Nucleo** boards
- Equipped with ST morpho connectors (top and bottom) and Arduino UNO R3 connectors (top) to allow stacking of multiple boards
- RoHS and WEEE compliant

The **X-NUCLEO-AMICAM1** expansion board implements an amplification stage for each microphone, based on TSV91x operational amplifiers, and allows microphone recording using either a dedicated third-party external analog to digital converter, mounted on-board, or the embedded STM32 ADC.

Figure 2. X-NUCLEO-AMICAM1, STM32 Nucleo and STEVAL-MIC004V1 stack

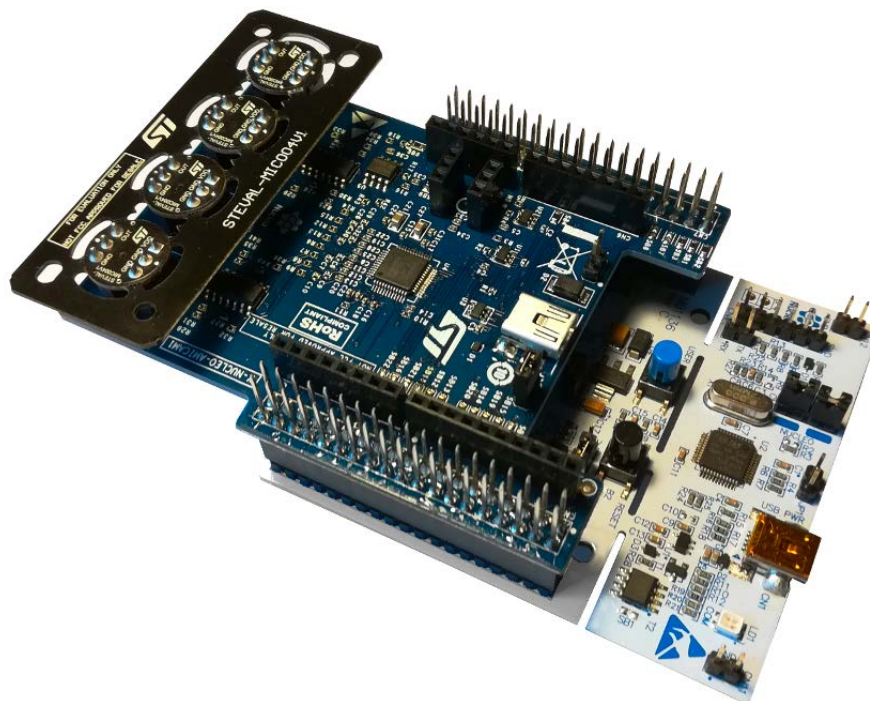

As shown in the figure above, three microphones are mounted on the **X-NUCLEO-AMICAM1** expansion board: 2 of them (M1OB, M2OB) are connected to the external ADC while the third one (M3OB) is directly connected to STM32 embedded ADC.

Five additional headers are available for external analog microphone coupon boards (e.g. **STEVAL-MIC004V1**). The external ADC is controlled through a SPI interface.

The expansion board provides also USB streaming using the STM32 Nucleo microcontroller USB peripheral; a USB connector is available for data and power supply.
Solder bridges allow choosing from different options, depending on the number of microphones and the MCU peripherals involved.

Figure 3. X-NUCLEO-AMICAM1 expansion board block diagram

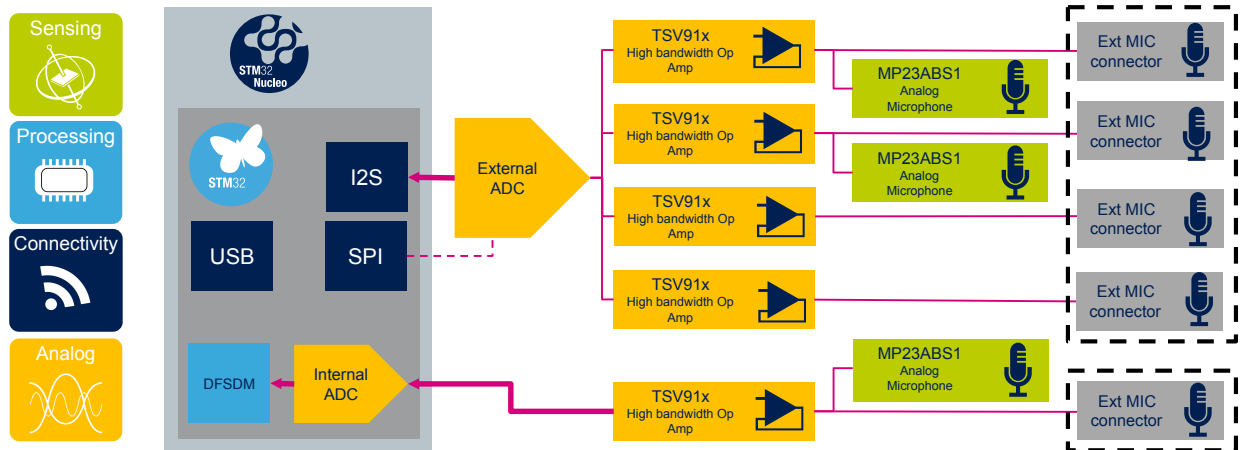

2 Hardware description

Two different solutions are implemented on the X-NUCLEO-AMICAM1 expansion board to allow MP23ABS1 evaluation in different scenarios:

- a low power and low cost solution using STM32 embedded ADC and TSV912 operational amplifier
- the use of a third party external ADC and TSV914 amplifier

Acoustic quality, power consumption hardware requirements (power supply and amplification circuits) differ on the basis of the chosen solution.

2.1 Amplification stage and signal acquisition - internal ADC

The STM32 analog to digital converter is used in single ended configuration: the microphone signal, in this case, is amplified around a common mode which is equal to half the VREF provided to the STM32 analog supply input (for further details on the power scheme, see [Figure 6. X-NUCLEO-AMICAM1 expansion board: power supply scheme](#)).

Figure 4. X-NUCLEO-AMICAM1 expansion board: amplification of a single microphone

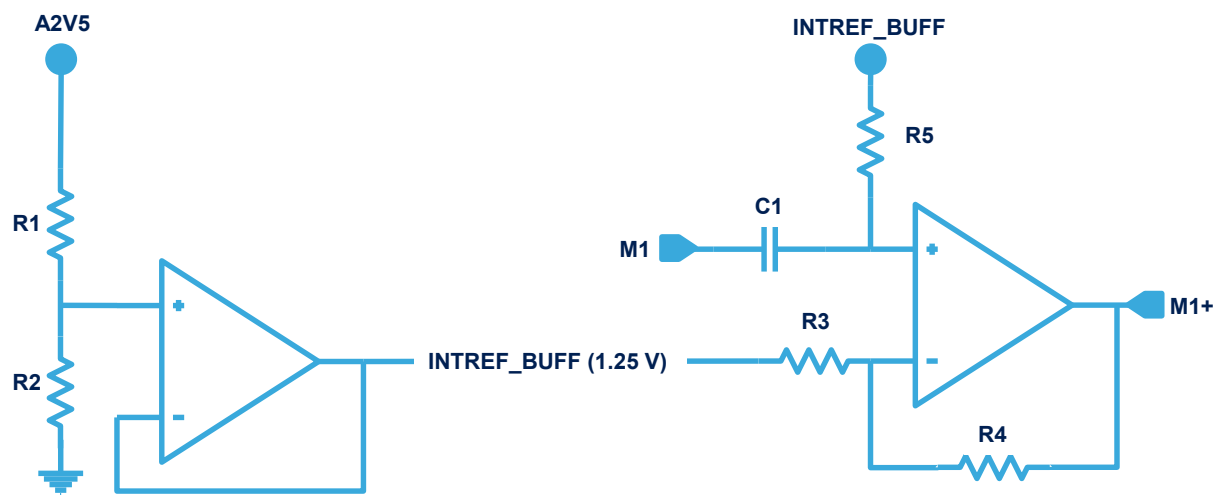

The first operational amplifier is used as a buffer for the bias signal generated by a voltage divider (with R1 equal to R2); the second one adds a gain equal to $1 + \frac{R4}{R3}$ to the microphone signal which is then routed to the STM32 ADC.

Depending on the STM32 Nucleo development board, different ADC configurations are possible, enabling several acquisition strategies which may include oversampling, filtering and decimation using DFSDM hardware peripheral to gain in SNR and bit depth.

2.2 Amplification stage and signal acquisition - external ADC

The adopted third party analog to digital converter has a differential interface: the microphone amplification stage performs both gain addition and single to differential conversion to exploit the ADC dynamics.

Figure 5. X-NUCLEO-AMICAM1 expansion board: amplification and conversion to differential

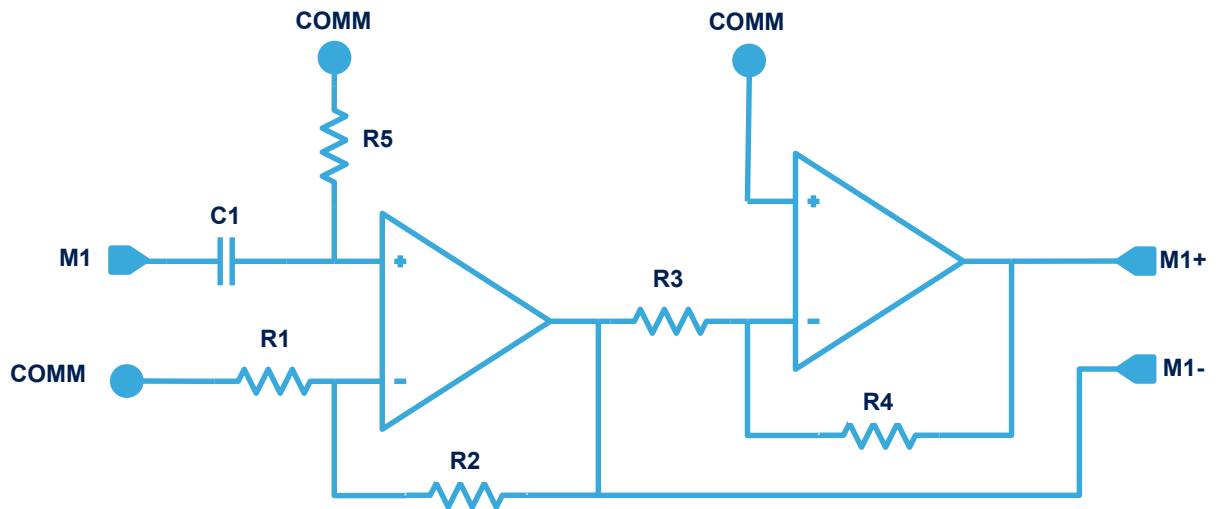

The first operational amplifier adds a gain equal to $1 + \frac{R2}{R1}$, while the second one, configured in inverting configuration with R3 equal to R4, simply adds a phase shift of 180 degrees to the amplified signal. The COMM represents the bias provided by the external ADC, which is controlled by an SPI interface, and microphone data are acquired by the STM32 through an I²S interface.

2.3 Power scheme

Power scheme is designed to provide separate supplies to the critical analog parts, which you can find on both the X-NUCLEO-AMICAM1 and the STM32 Nucleo boards.

Figure 6. X-NUCLEO-AMICAM1 expansion board: power supply scheme

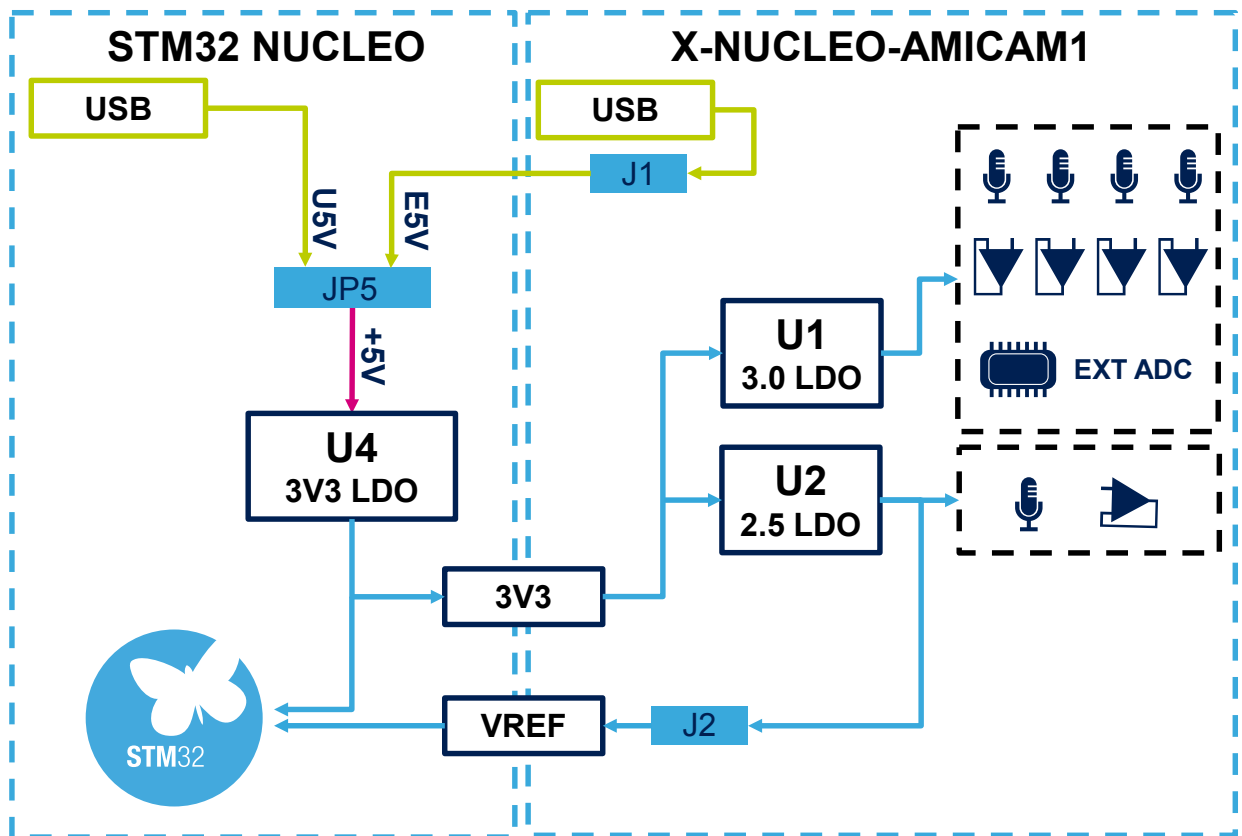

All the analog supplies are generated starting from the 3V3 coming from the LDO on the *STM32 Nucleo* boards. Starting from this source, two different regulators are used on the *X-NUCLEO-AMICAM1* expansion board:

- U1 LDO which outputs 3 volts used by the microphones connected to the external ADC and all the relevant components
- U2 LDO which generates 2.5 volts and feeds the single microphone connected to the internal *STM32* ADC as well as the *STM32* analog reference

Note: *in the standard board configuration, the single microphone (M3OB) connected to the STM32 ADC is disabled by default; to enable this feature two actions are required:*

- *unsolder a solder bridge on the STM32 Nucleo (the solder bridge depends on the STM32 Nucleo type, as detailed in Section 3.1.2 Single microphone acquisition configuration)*
- *close J2 header*

Caution: Do not close J2 if the proper solder bridge is not open on the *STM32 Nucleo* board, as the *STM32 Nucleo* and the *X-NUCLEO-AMICAM1* expansion board could be damaged (refer to Section 3.1 Board setup for further information).

The on-board USB connector supports audio streaming to the host PC and can also be used to power the whole system up, including the *STM32 Nucleo* board, by:

- closing jumper J1 on the *X-NUCLEO-AMICAM1* expansion board
- placing JP5 in position E5 on the *STM32 Nucleo* development board

2.4 Solder bridges

Solder bridges allow you to choose among different configurations and enable or disable on-board microphones versus microphone coupon boards.

Table 1. X-NUCLEO-AMICAM1: solder bridge functions

Function	Solder bridge
I ² S serial data 2 from external ADC	SB1
I ² S bit clock to external ADC	SB2
I ² S serial data 1 from external ADC	SB3
I ² S word select	SB4
Amplified single microphones to STM32 ADC pin	SB6
NRST signal to external ADC reset pin	SB7
NRST signal to external ADC reset pin	SB8
Microphone coupon M5 connected to STM32 ADC	SB9
On-board microphone M3OB connected to STM32 ADC	SB10
I ² S master clock to external ADC	SB11
SPI CS to external ADC	SB12
SPI MOSI to external ADC	SB13
SPI MISO from external ADC	SB14
SPI clock	SB15
I ² S bit clock to external ADC	SB16
I ² S master clock to external ADC	SB18
USB DP signal	SB19
USB DM signal	SB20
I ² S serial data 2 from external ADC	SB21
I ² S bit clock to external ADC	SB22
Microphone coupon M1 connected to external ADC	SB23
On-board microphone M1OB connected to external ADC	SB24
Microphone coupon M2 connected to external ADC	SB25
On-board microphone M2OB connected to external ADC	SB26

2.5 Connectors

Table 2. X-NUCLEO-AMICAM1 expansion board: ST morpho connectors

Connector	Pin	Signal	Remarks
CN7	1	I2S_CK	
	2	I2S_SD2	
	3	I2S_SD1	
	4	NRST	
	6	E5V	
	8	GND	
	12	3V3	
	14	NRST	
	16	3V3	
	17	I2S_WS	

Connector	Pin	Signal	Remarks
CN7	18	5V	
	19	GND	
	20	GND	
	22	GND	
	28	M5+	
CN10	1	SPI_CS	
	4	I2S_MCLK	
	7	A2V5	If J2 is closed
	9	GND	
	11	SPI1_SCK	
	12	OTG_FS_DP_NUCLEO	
	13	SPI_MISO	
	14	OTG_FS_DM_NUCLEO	
	15	SPI1_MOSI	
	19	I2S_MCLK	
	20	GND	
	25	I2S_CK	
	26	I2S_SD2	
	30	I2S_CK	
32	AGND		

Table 3. X-NUCLEO-AMICAM1 expansion board: Arduino connectors

Connector	Pin	Signal	Remarks
CN6	2	3V3	
	3	NRST	
	4	3V3	
	5	5V	
	6	GND	
	7	GND	
	8	V_IN	
CN8	1	M5+	
CN5	2	I2S_MCLK	
	4	SPI_MOSI	
	5	SPI_MISO	
	6	SPI_SCK	
	7	GND	
	8	A2V5	If J2 is closed
CN9	7	I2S_CK	

3 System requirements

To use the [X-NUCLEO-AMICAM1](#) expansion board, you need the same hardware and software resources of [STM32 Nucleo](#) boards (for details, refer to UM1724 on www.st.com) as well as 40 MB of free space on your hard disk and at least 128 MB of RAM to run the firmware package.

3.1 Board setup

The [X-NUCLEO-AMICAM1](#) expansion board can be connected to any [STM32 Nucleo](#) board. However, the related firmware offers an out-of-the-box package for some [STM32 Nucleo](#) boards.

When mounting the [X-NUCLEO-AMICAM1](#) on the [STM32 Nucleo](#), align all the pins with their corresponding connector.

Caution: Handle the boards carefully during this operation and implement ESD prevention measures to avoid damaging (or bending) the male/female pins, connectors and the expansion board components.

The default [X-NUCLEO-AMICAM1](#) configuration allows the acquisition of two on-board microphones (M1OB and M2OB) through the external ADC mounted on the board.

The following configurations and use cases can also be implemented:

- 4 microphone acquisition using coupon boards (e.g. [STEVAl-MIC004V1](#)) and the external ADC
- single microphone acquisition using [STM32](#) embedded ADC

3.1.1 4 microphone acquisition configuration

Step 1. Open SB24 and SB26 to disconnect M1OB and M2OB on-board microphones from the ADC

Step 2. Close SB23 and SB25 to connect M1 and M2 external headers to the ADC

Step 3. Mount coupon boards on the headers

Caution: Do not close SB23 and SB24 at the same time to avoid potential shortcircuit between M1OB on-board microphone and M1 external microphone if the coupon is mounted.

Do not close SB25 and SB26 at the same time: it will result in a potential shortcut between M2OB onboard microphone and M2 external microphone if the coupon is mounted.

3.1.2 Single microphone acquisition configuration

Step 1. Change the solder bridge configuration on the [STM32 Nucleo](#) to allow VREF routing to the appropriate [STM32](#) pin as follows:

- On [STM32 Nucleo-XXXXRX](#) 64-pin boards (MB1136): open SB57
- On [STM32 Nucleo-LXXXXX](#) 144-pin boards (MB1312): open SB149, close SB 119
- On [STM32 Nucleo-XXXXZX](#) 144-pin boards (MB1137): open SB12

Step 2. Close J2 on the [X-NUCLEO-AMICAM1](#) board.

Caution: Do not close J2 if the proper solder bridge is not open on the [STM32 Nucleo](#) board, as the [STM32 Nucleo](#) and the [X-NUCLEO-AMICAM1](#) expansion board could be damaged.

Step 3. Check SB9 and SB10 on the [X-NUCLEO-AMICAM1](#).

- SB10 closed, SB9 open: acquisition of the on-board M3OB microphone
- SB10 open, SB9 closed: acquisition of an external coupon plugged onto M5 header

Caution: Do not close SB9 and SB10 at the same time as a potential shortcircuit could occur between M3OB on-board microphone and M5 external microphone if the coupon board is mounted.

4 Bill of materials

Table 4. X-NUCLEO-AMICAM1 bill of materials

Item	Q.ty	Ref.	Part / Value	Description	Manufacturer	Order code
1	1	CN5	HEADER 10	Arduino connector	Samtec or equivalent	SSQ-110-21-F-S
2	2	CN6, CN9	HEADER 8	Arduino connectors	Samtec or equivalent	SSQ-108-21-F-S
3	2	CN7, CN10	HEADER 19x2	Morpho connectors	Samtec or equivalent	SSQ-119-01-L-D
4	1	CN8	HEADER 6	Arduino connector	Samtec or equivalent	SSQ-106-21-F-S
5	20	C1, C2, C4, C5, C8, C11, C12, C13, C19, C22, C25, C28, C33, C35, C37, C38, C39, C40, C43, C44	1 μ F X5R \pm 10% 0402 (1005 Metric)	Ceramic capacitors	Kemet	C0402C105K8PAC7411
6	11	C3, C14, C15, C16, C17, C18, C24, C31, C34, C41, C42	100 nF 16 V X7R \pm 10% 0402 (1005 Metric)	Ceramic capacitors	Kemet	C0402C104K4RAC7411
7	8	C6, C7, C9, C10, C26, C29, C30, C32	10 nF 16 V X7R \pm 10% 0402 (1005 Metric)	Ceramic capacitors (not mounted)	Yageo	CC0402KRX7R7BB103
8	1	C20	39 nF 25 V X7R \pm 10% 0402 (1005 Metric)	Ceramic capacitor	Murata	GRM155R71E393KA88D
9	1	C21	47 μ F 10 V X5R \pm 20% 0805 (2012 Metric)	Ceramic capacitor	Taiyo Yuden	LMK212BBJ476MG-T
10	1	C23	2.2 nF 16 V X7R \pm 10% 0402 (1005 Metric)	Ceramic capacitor	Würth Elektronik	885000000000
11	1	C27	10 μ F 10 V X5R \pm 10% 0805 (2012 Metric)	Ceramic capacitor	Samsung Electro-MechanicsMurata	CL21A106KPFNNNG
12	1	C36	10 nF 16 V X7R \pm 10% 0402 (1005 Metric)	Ceramic capacitor	Yageo	CC0402KRX7R7BB103
13	1	D1	ESDA7P60-1U1M	High junction temperature Transil	ST	ESDA7P60-1U1M
14	1	D2	STPS160A	Schottky diode	ST	STPS160A
15	2	J1, J2	HEADER 2	Stripline TH 2 pin	Harwin	M20-9773646
16	3	M10B, M20B, M30B	MP23ABS1	High performance MEMS audio sensor single ended analog bottom-port microphone	ST	MP23ABS1TR
17	5	M1, M2, M3, M4, M5	HEADER 3X2	Analog microphone coupon connector	Fischer Elektronik or equivalent	BL1/36Z

Item	Q.ty	Ref.	Part / Value	Description	Manufacturer	Order code
18	1	R1	1.5 K OHM ±1% 1/16 W 0402 (1005 Metric)	SMD resistor (not mounted)	Vishay	CRCW04021K50FKED
19	1	R2	33 K OHM ±1% 1/16 W 0402 (1005 Metric)	SMD resistor	Vishay	CRCW040233K0FKED
20	1	R3	12 K OHM ±1% 1/16 W 0402 (1005 Metric)	SMD resistor	Vishay	CRCW040212K0FKED
21	1	R4	51 K OHM ±1% 1/16 W 0402 (1005 Metric)	SMD resistor	Vishay	CRCW040251K0FKED
22	1	R5	24 K OHM ±1% 1/16 W 0402 (1005 Metric)	SMD resistor	Vishay	CRCW040224K0FKED
23	8	R6, R7, R8, R9, R12, R13, R14, R15	0 OHM ±1% 0.2 W 0402 (1005 Metric)	SMD resistors	Vishay	CRCW04020000Z0EDHP
24	9	R10, R25, R28, R29, R32, R33, R36, R38, R41	10 K OHM ±1% 1/16 W 0402 (1005 Metric)	SMD resistors	Panasonic	ERA2AEB103X
25	1	R11	3.32 K OHM ±1% 0.1 W 0402 (1005 Metric)	SMD resistor	Panasonic	ERJ-2RKF3321X
26	9	R16, R22, R23, R24, R30, R31, R34, R35, R37	56 K OHM ±1% 0.12 W 0402 (1005 Metric)	SMD resistors	TE Connectivity	CRGP0402F56K
27	1	R17	160 OHM ±1% 1/16 W 0402 (1005 Metric)	SMD resistor	TE Connectivity	CPF0402B160RE1
28	1	R18	4.7 K OHM ±1% 1/16 W 0402 (1005 Metric)	SMD resistor	ROHM	MCR01MZPF4701
29	1	R19	100 K OHM ±1% 0.12 W 0402 (1005 Metric)	SMD resistor	TE Connectivity	CRGP0402F100K
30	4	R26, R27, R39, R40	2 K OHM ±1% 1/16 W 0402 (1005 Metric)	SMD resistors	Vishay	CRCW04022K00FKED
31	2	R42, R43	1 M OHM ±1% 1/16 W 0402 (1005 Metric)	SMD resistors	Vishay	CRCW04021M00FKED
32	14	SB1, SB2, SB3, SB4, SB6, SB10, SB12, SB13, SB14, SB15, SB19, SB20, SB24, SB26	0 OHM ±1% 0.1 W 0603 (1608 Metric)	SMD resistor	Vishay	CRCW06030000Z0EB
33	10	SB7, SB8, SB9, SB11, SB16, SB18, SB21, SB22, SB23, SB25	0 OHM ±1% 0.1 W 0603 (1608 Metric)	SMD resistors (not mounted)	Vishay	CRCW06030000Z0EB
34	1	SP1		Not mounted	Any	Any
35	1	USB1	USB Mini-B	USB connector	CUI	UJ2-MBH-1-SMT-TR

Item	Q.ty	Ref.	Part / Value	Description	Manufacturer	Order code
36	2	U1, U2	LDK130M-R	300 mA low quiescent current very low noise LDO	ST	LDK130M-R
37	1	U3	USBLC6-2SC6	ESD protection for USB 2.0 high speed	ST	USBLC6-2SC6
38	1	U4	AD1974	4-channel differential ADC	Analog Devices	AD1974YSTZ
39	1	U5	TSV912	Wide-bandwidth (8MHz) rail to rail input/output 5 V CMOS Op-Amps, dual	ST	TSV912
40	2	U6, U7	TSV914	Wide-bandwidth (8MHz) rail to rail input/output 5 V CMOS Op-Amps, quad	ST	TSV914

5 Schematic diagrams

Figure 7. X-NUCLEO-AMICAM1 circuit schematic - connectors

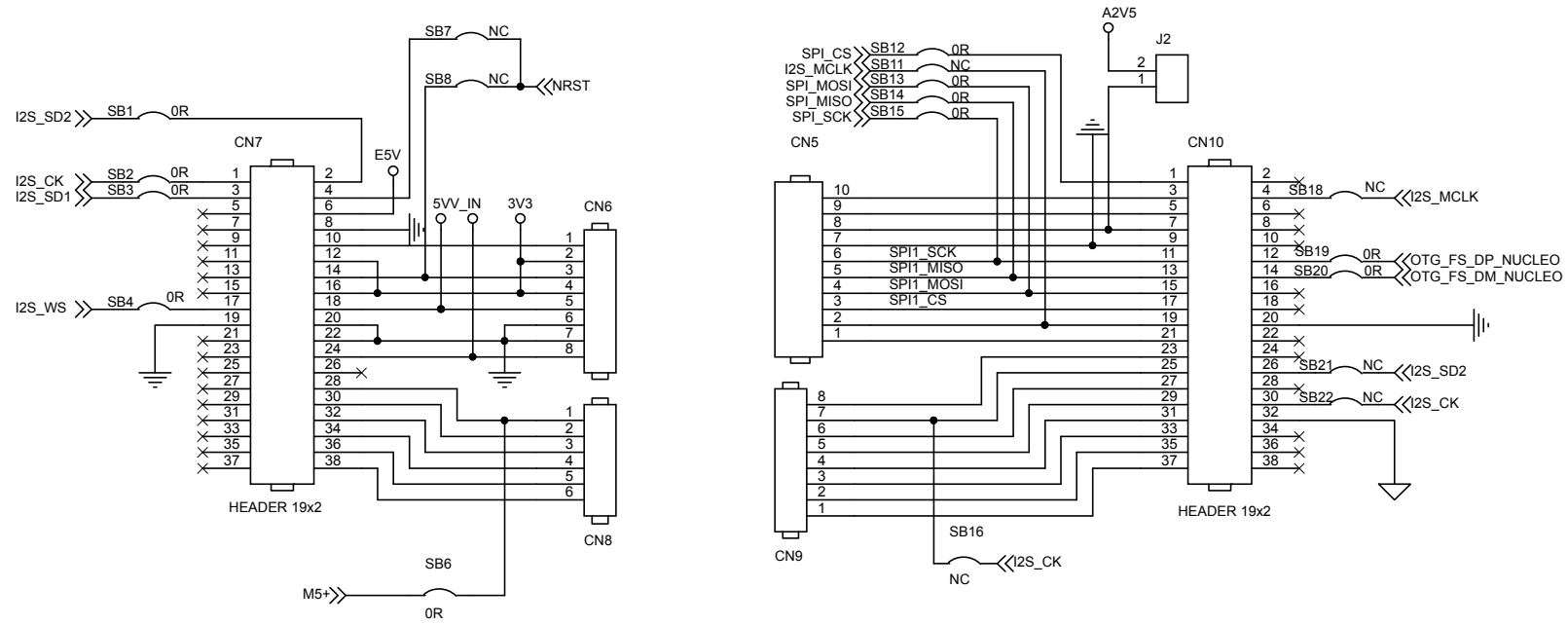

Figure 8. X-NUCLEO-AMICAM1 circuit schematic - USB, power, external ADC

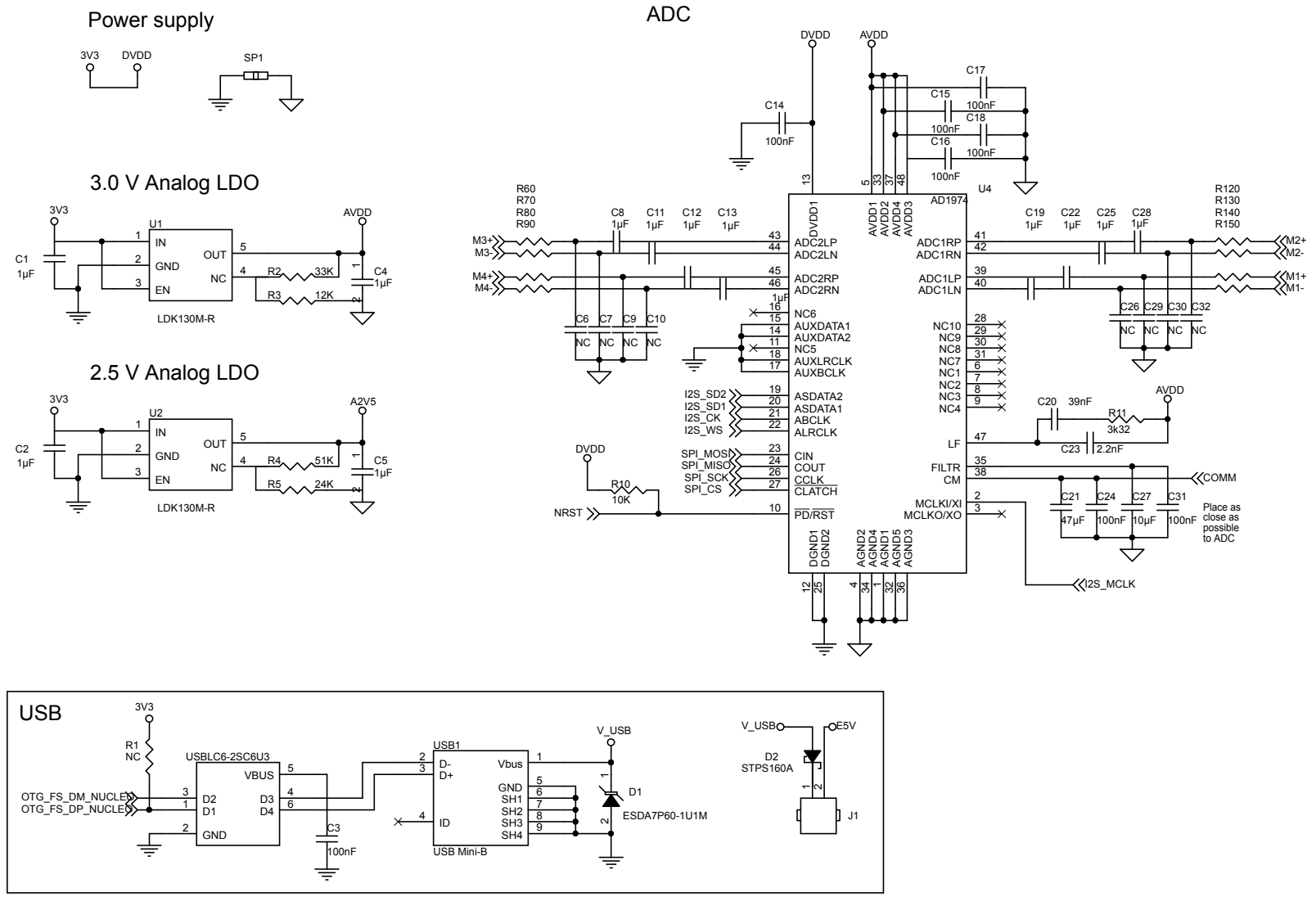
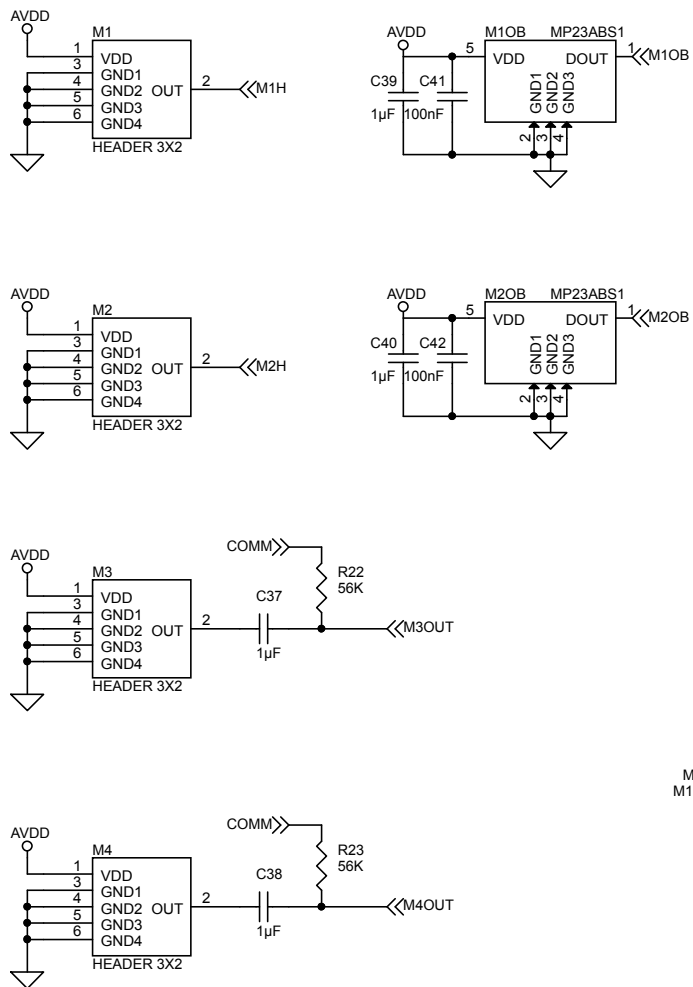

Figure 9. X-NUCLEO-AMICAM1 circuit schematic - microphones to external ADC

Microphones



OpAmp

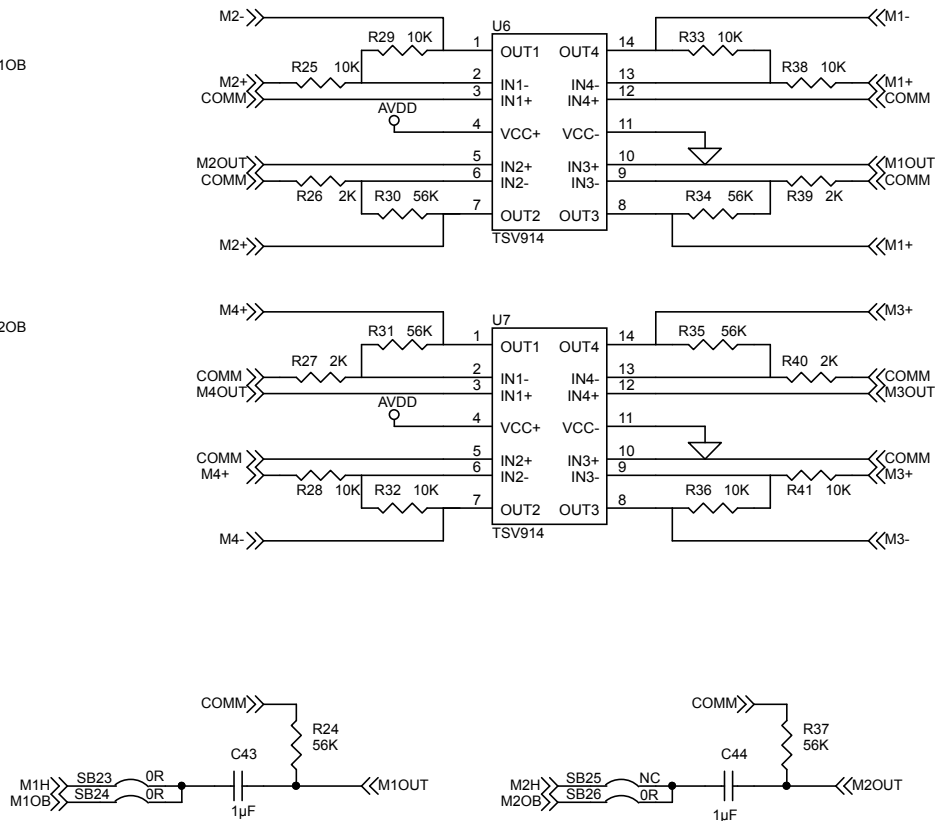
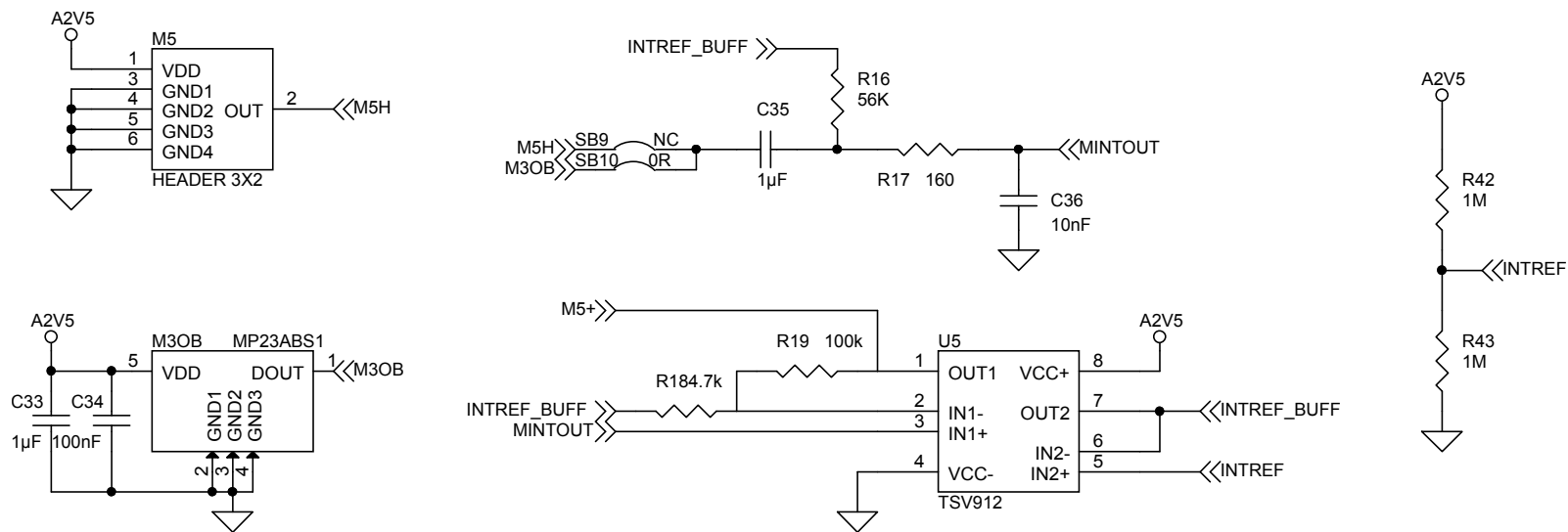

Figure 10. X-NUCLEO-AMICAM1 circuit schematic - microphones to internal ADC

HP Filter --> $f_c = 2.8\text{Hz}$
 LP Filter --> $f_c = 99.4\text{KHz}$



Revision history

Table 5. Document revision history

Date	Version	Changes
09-Dec-2019	1	Initial release.
20-Mar-2020	2	Updated Section 1 Overview and Table 2. X-NUCLEO-AMICAM1 expansion board: ST morpho connectors.

IMPORTANT NOTICE – PLEASE READ CAREFULLY

STMicroelectronics NV and its subsidiaries (“ST”) reserve the right to make changes, corrections, enhancements, modifications, and improvements to ST products and/or to this document at any time without notice. Purchasers should obtain the latest relevant information on ST products before placing orders. ST products are sold pursuant to ST’s terms and conditions of sale in place at the time of order acknowledgement.

Purchasers are solely responsible for the choice, selection, and use of ST products and ST assumes no liability for application assistance or the design of Purchasers’ products.

No license, express or implied, to any intellectual property right is granted by ST herein.

Resale of ST products with provisions different from the information set forth herein shall void any warranty granted by ST for such product.

ST and the ST logo are trademarks of ST. For additional information about ST trademarks, please refer to www.st.com/trademarks. All other product or service names are the property of their respective owners.

Information in this document supersedes and replaces information previously supplied in any prior versions of this document.

© 2020 STMicroelectronics – All rights reserved