

May.1.2023 Copyright 2023 HIROSE ELECTRIC CO., LTD. All Rights Reserved.
In case of consideration for using Automotive equipment / device which demand high reliability, kindly contact our sales window correspondents.

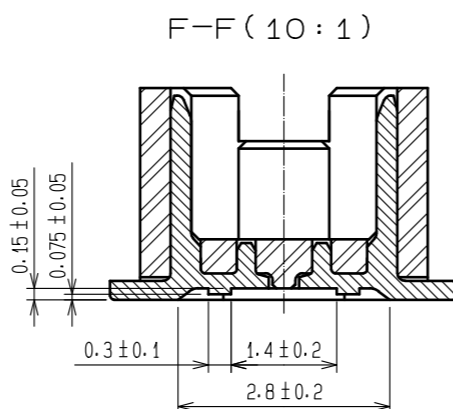

CODE No.	CONTACT	A	B	C	D	E
CL537-0499-0-51	20	7.2	4.5	5.3	5.7	5.3
CL537-0587-0-51	30	9.7	7.0	7.8	8.2	7.8
CL537-0588-0-51	36	11.2	8.5	9.3	9.7	9.3
CL537-0589-0-51	40	12.2	9.5	10.3	10.7	10.3
CL537-0590-0-51	50	14.7	12.0	12.8	13.2	12.8
CL537-0591-0-51	60	17.2	14.5	15.3	15.7	15.3

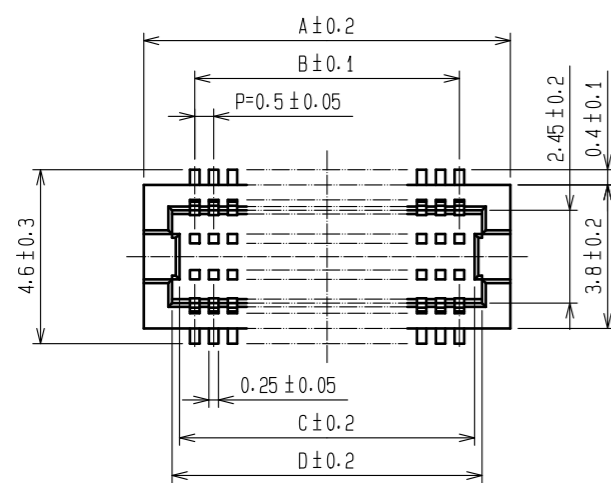
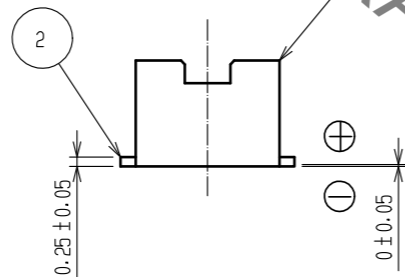
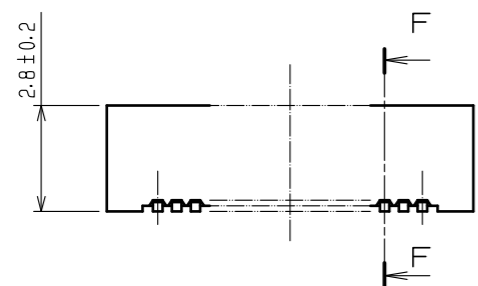

RECOMMEND METAL MASK PATTERN (10:1)

RECOMMENDED LAND PATTERN (10:1)

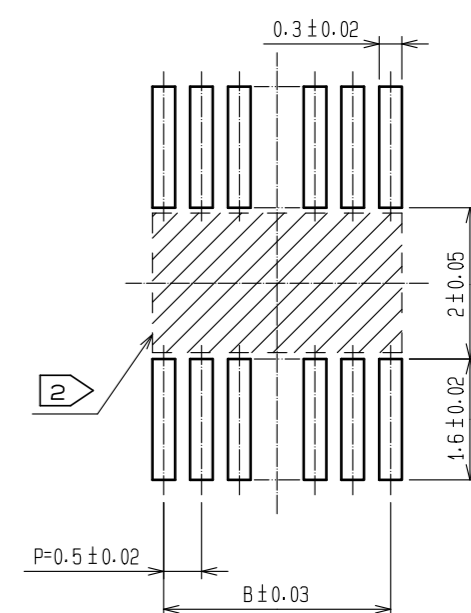
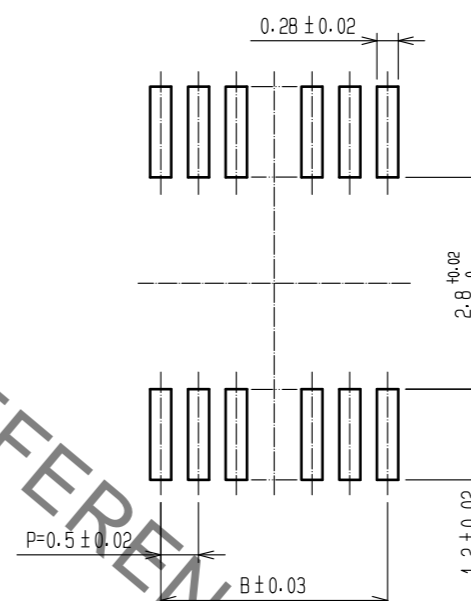

METAL MASK THICKNESS : 120 μm

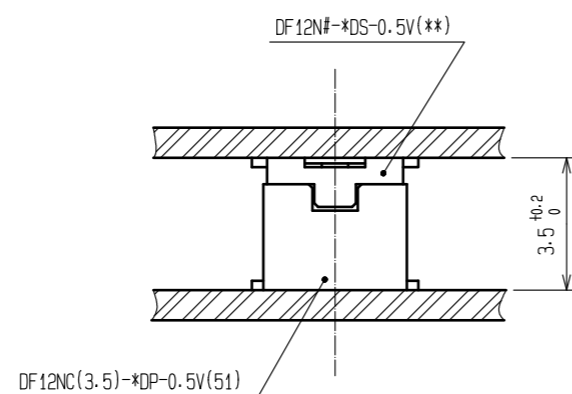
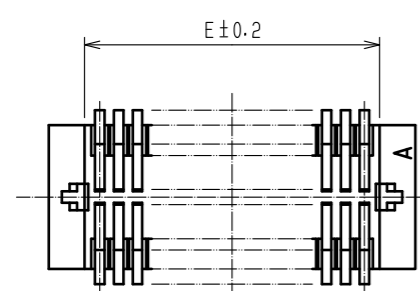

NOTES 1 LEAD CO-PLANARITY SHALL BE 0.08 mm MAX.
2 IF THERE IS PATTERN ON PART, THERE IS A POSSIBILITY THAT IT WILL MAKE CONTACT WITH THE LEADS.

NO.	MATERIAL	FINISH . REMARKS	NO.	MATERIAL	FINISH . REMARKS
2	PHOSPHOR BRONZE	CONTACT AREA:GOLD PLATED 0.2μm min LEAD AREA:GOLD PLATED 0.015μm min OTHERS(UNDER PLATING):NICKEL PLATED 2μm min	6	PS	CLEAR (REINFORCEMENT COLLAR)
			5	PS	BLACK (PLASTIC REEL)
			4	POLYESTER	CLEAR (COVER TAPE)
1	POLYAMIDE	UL94V-0.BLACK	3	PS	CLEAR (EMBOSSED CARRIER TAPE)

UNITS	SCALE	COUNT	DESCRIPTION OF REVISIONS	DESIGNED	CHECKED	DATE
mm	5 : 1	0				

HRS HIROSE ELECTRIC CO., LTD.	APPROVED : WR. FUKUCHI	20200702	DRAWING NO.	EDC-390690-51-77
	CHECED : TS. MIYAZAKI	20200702	PART NO.	DF12NC(3.5)-*DP-0.5V(51)
	DESIGNED : RN. IIDA	20200702	CODE NO.	CL537
	DRAWN : RN. IIDA	20200702		

May.1.2023 Copyright 2023 HIROSE ELECTRIC CO., LTD. All Rights Reserved.
In case of consideration for using Automotive equipment / device which demand high reliability, kindly contact our sales window correspondents.

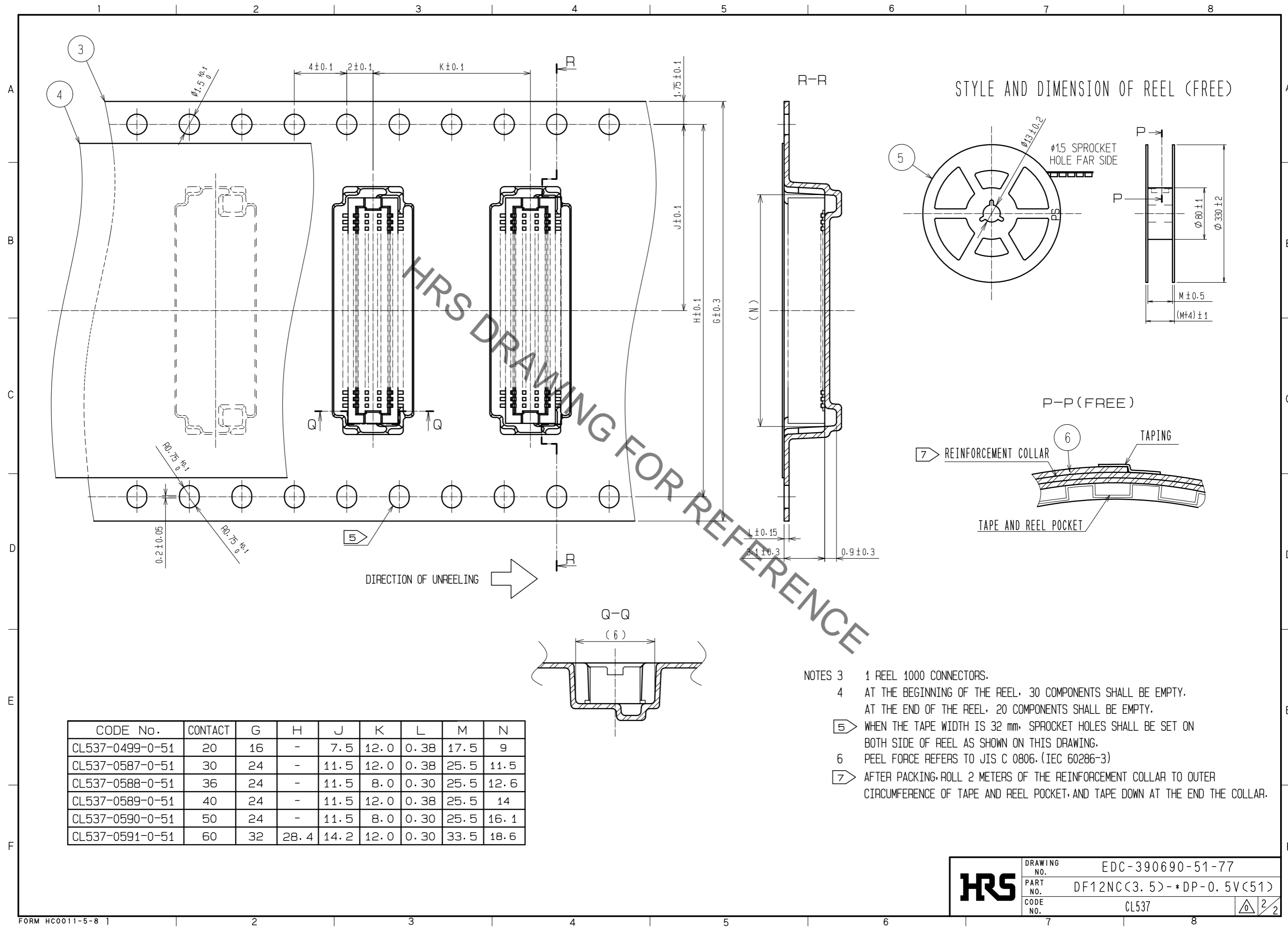

HRS DRAWING FOR REFERENCE

CODE No.	CONTACT	G	H	J	K	L	M	N
CL537-0499-0-51	20	16	-	7.5	12.0	0.38	17.5	9
CL537-0587-0-51	30	24	-	11.5	12.0	0.38	25.5	11.5
CL537-0588-0-51	36	24	-	11.5	8.0	0.30	25.5	12.6
CL537-0589-0-51	40	24	-	11.5	12.0	0.38	25.5	14
CL537-0590-0-51	50	24	-	11.5	8.0	0.30	25.5	16.1
CL537-0591-0-51	60	32	28.4	14.2	12.0	0.30	33.5	18.6

- NOTES
- 3 1 REEL 1000 CONNECTORS.
 - 4 AT THE BEGINNING OF THE REEL, 30 COMPONENTS SHALL BE EMPTY.
AT THE END OF THE REEL, 20 COMPONENTS SHALL BE EMPTY.
 - 5 WHEN THE TAPE WIDTH IS 32 mm, SPROCKET HOLES SHALL BE SET ON BOTH SIDE OF REEL AS SHOWN ON THIS DRAWING.
 - 6 PEEL FORCE REFERS TO JIS C 0806. (IEC 60286-3)
 - 7 AFTER PACKING, ROLL 2 METERS OF THE REINFORCEMENT COLLAR TO OUTER CIRCUMFERENCE OF TAPE AND REEL POCKET, AND TAPE DOWN AT THE END THE COLLAR.

HRS	DRAWING NO.	EDC-390690-51-77	
	PART NO.	DF12NC(3.5)-*DP-0.5V(51)	
	CODE NO.	CL537	2/2