

REVISIONS				
ZONE	REV	DESCRIPTION	DATE	APPROVED

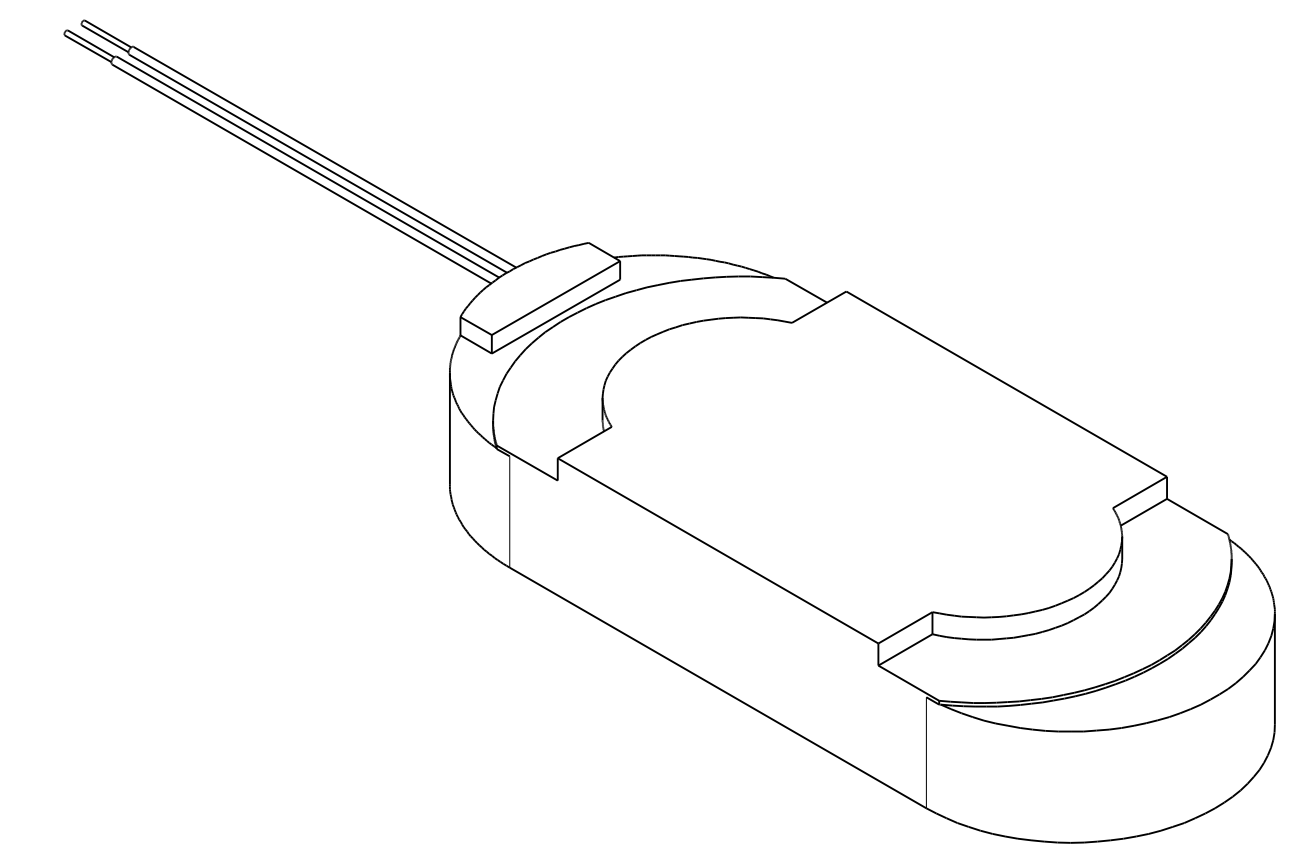

No.	Part Name	Material	Quantity
-----	-----------	----------	----------

1	UL1571 AWG32#	RED/BLACK	2
2	PCB	FR-4	1
3	Frame	PBT	1
4	Magnet	Nd Fe B	1
5	Plate	SPCC	1
6	Voice Coil	Copper	1
7	Membrane	PEN	1
8	Cap	SUS303	1
9	Gasket	BLACK NET	1
10	Screen	BLACK NET	1

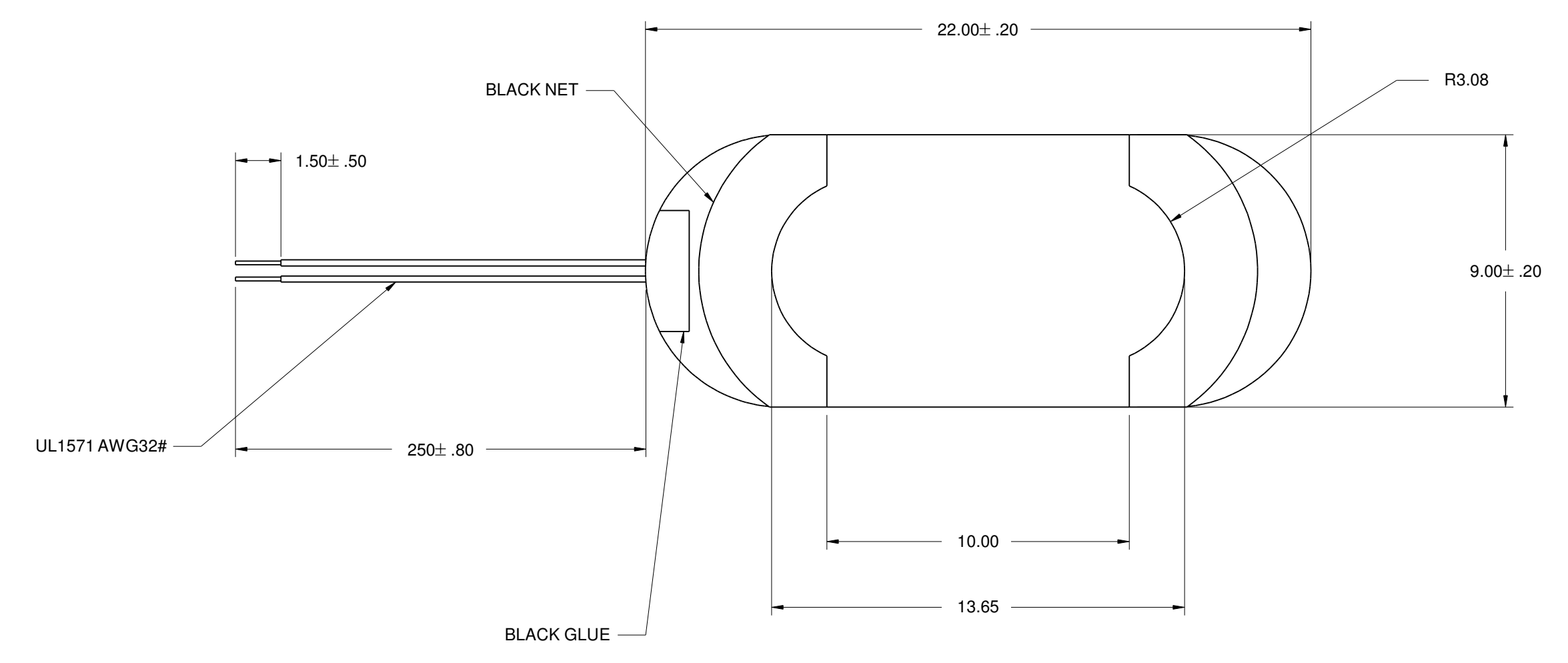
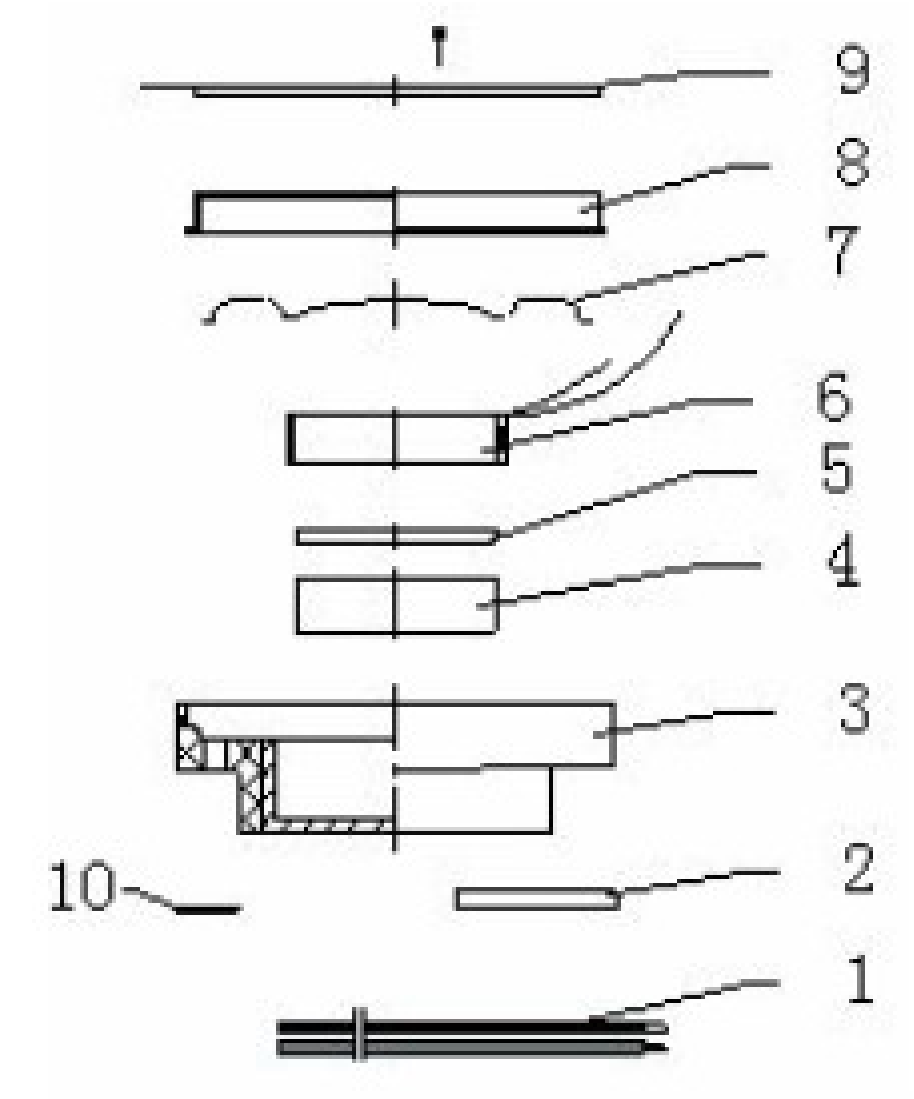
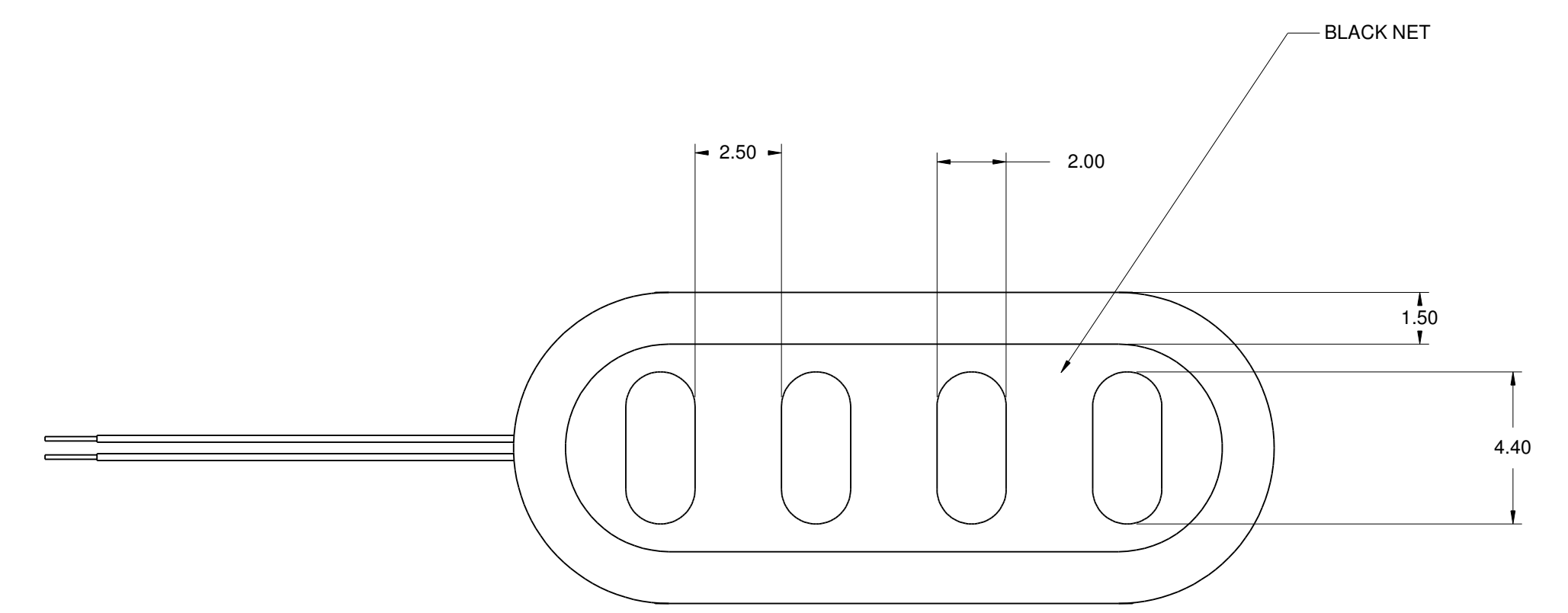
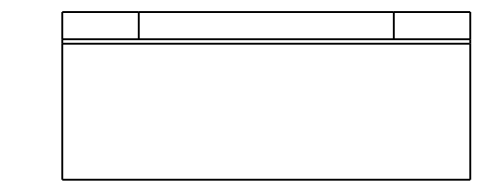
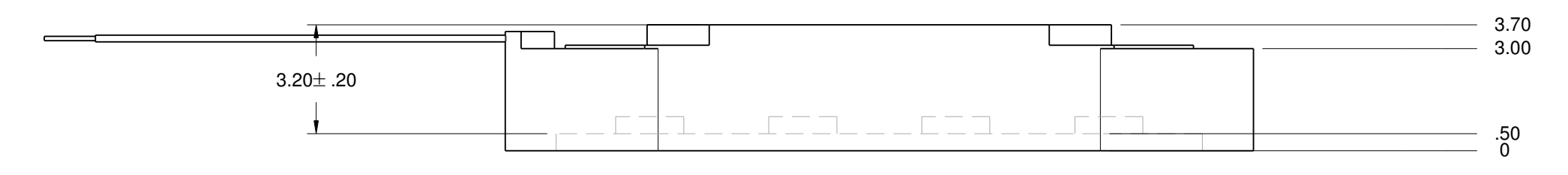

SIZE	FSCM NO.	DWG NO.	REV
D		SP-2209	
SCALE	1:1	SHEET	1 OF 1