

SW2011

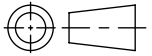

Revision Level		Revision Record	Changed	Date	Approved	Date
Drawing	Part					
03	A	SEE ECN# 012204	MHT	10/18/2012	MHT	10/18/2012

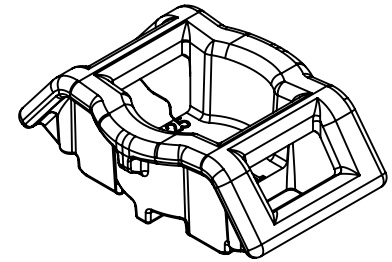
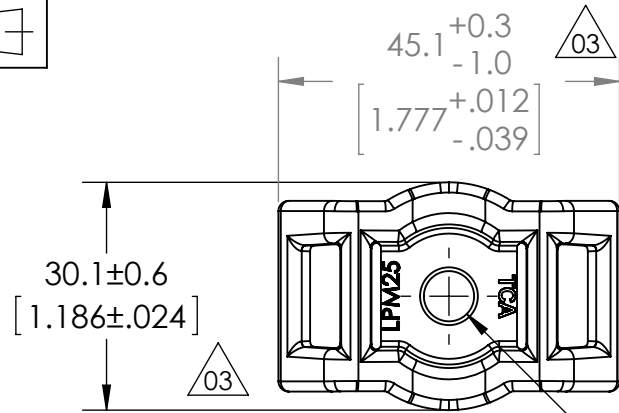

Ø6.65
[.262]

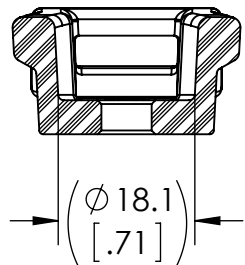

SECTION B-B

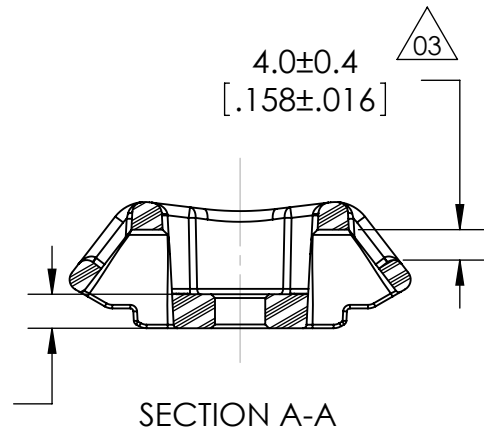
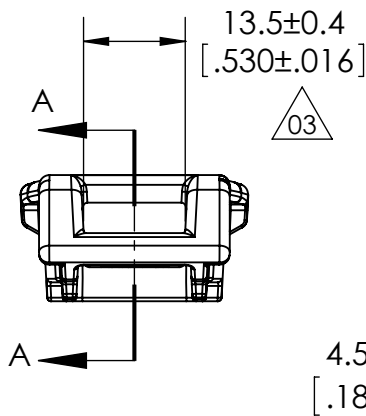
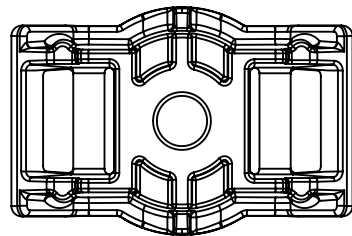
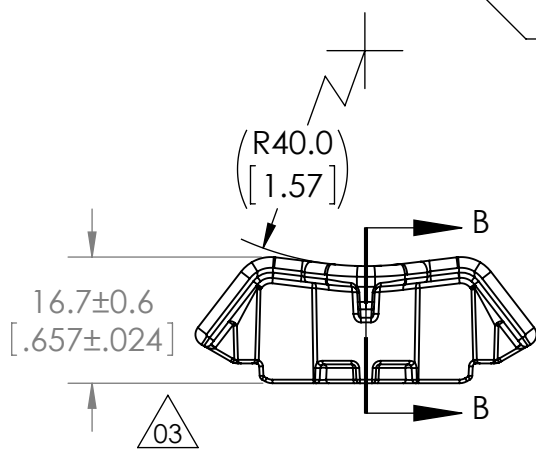

SECTION A-A

NOTES:

1. MAXIMUM TORQUE NOT TO EXCEED; 11.3 Nm (100 in/lb)

Material
PA66HIRHSUV

Units: millimeters

Dimension without tolerances details to:

- .xxx = ±.013
- .xx = ±.13
- .x = ±.3
- None = ±.8
- < = ±0.5°

The copyright of this drawing is reserved by HellermannTyton. It is issued on condition that it is not reproduced, copied, or disclosed to a third party, either wholly or in part, without the consent of HellermannTyton.

Drawn	LAW	04/11/2012
Approved	LAW	04/11/2012

HellermannTyton

North America
Email: corp@htamericas.com
Web: www.hellermann.tyton.com

Article/Type-No LPM25

Title
LOW PROFILE MOUNT
FOR 6mm OR 0.25in HEX HEAD BOLT

Drawing-No

12-0302-001-CSU

Production : Phase

Scale 1:1

Project Number

PRP 12-0302

Format AH

Sheet 1/1