

NOTES: UNLESS OTHERWISE SPECIFIED

1. COSMETIC SPECIFICATION REFER TO WI-QA-038.

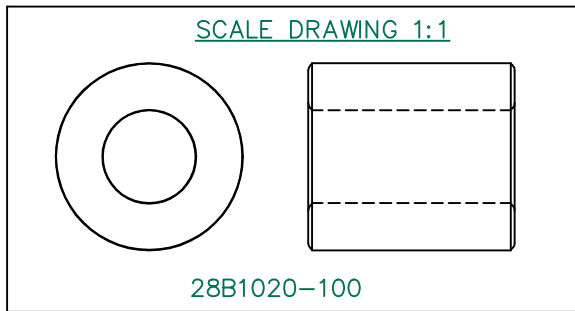

IMPEDANCE (Z)			
Frequency	25 MHz	100 MHz	300 MHz
Nominal (REF)	147 Ω	276 Ω	412 Ω
Minimum	- Ω	220 Ω	- Ω

Z vs. FREQUENCY
(REF. ONLY)

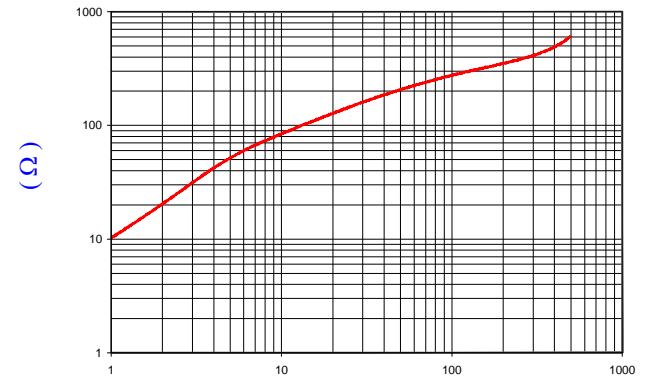

FREQUENCY (MHz)

AGILENT E4991A Impedance/Material Analyzer
HP 16092A-Test Fixture

FERRITE CORE DIMENSIONS (SPEC): mm [in]

A	25.91 [1.020]	±	0.46 [.018]
B	12.83 [.505]	±	0.25 [.010]
C	28.58 [1.125]	±	0.76 [.030]

WEIGHT/1000 56.01 kgs [123.49 Lbs]

DIMENSIONS ARE IN mm [INCHES].				This print is the property of Laird Tech. and is loaned in confidence subject to return upon request and with the understanding that no copies shall be made without the written consent of Laird Tech. All rights to design or invention are reserved.			
REV	DESCRIPTION	DATE	INT				
G	UPDATE THE LOGO	05/13/15	QIU	PROJECT/PART NUMBER:		REV	DRAWN BY:
F	UPDATE COMPANY LOGO & DETAIL A CALLOUT	4/15/09	JRK	28B1020-100		G	DJB
E	UPDATE FORMAT & Z SPECS, ADD CURVE REM COATING SPECS, CHG P/N FROM 10*	07/22/03	JRK	DATE:	07/03/90	SCALE:	1.5 : 1
				CAD #	28B1020-100-G	TOOL #	B1020
						MATERIAL: FERRITE	