

May.1.2023 Copyright 2023 HIROSE ELECTRIC CO., LTD. All Rights Reserved.
In case of consideration for using Automotive equipment / device which demand high reliability, kindly contact our sales window correspondents.

COUNT	DESCRIPTION OF REVISIONS	BY	CHKD	DATE	COUNT	DESCRIPTION OF REVISIONS	BY	CHKD	DATE

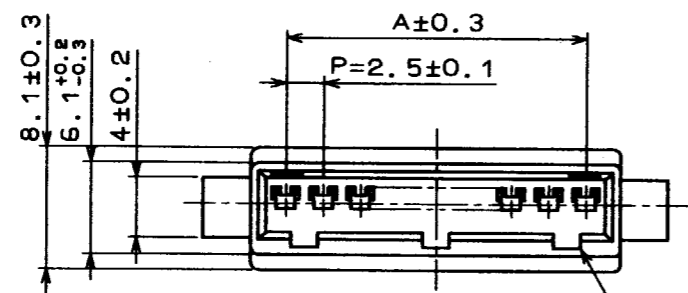

NOTE 1
HRS DRAWING FOR REFERENCE

< PANEL CUT-OUT >

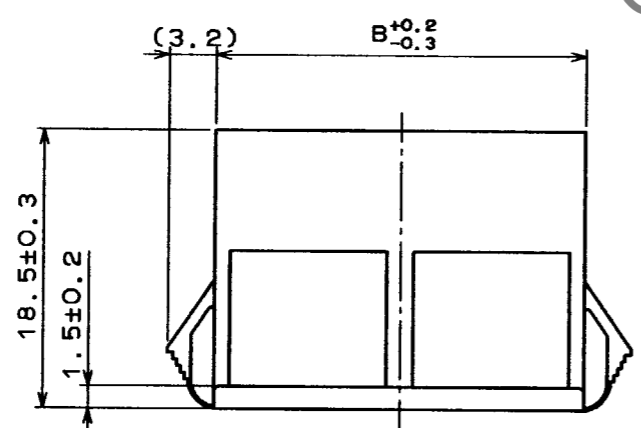
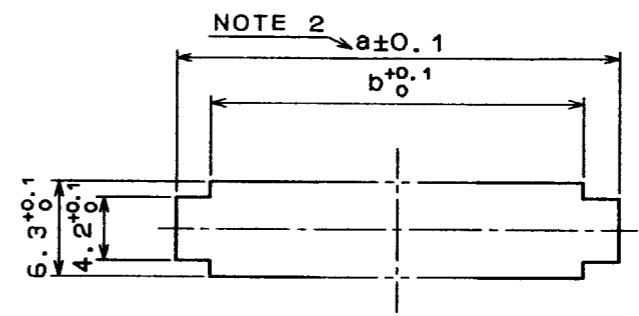

CL No.	PART No.	A	B	PANEL CUT-OUT			
				PANEL THICKNESS			b
				0.5-1.2	1.3-1.6	1.7-2.0	
CL541-0700-9	DF1BA- 2EP-2.5RC	2.5	7.1	11.2	11.9	12.6	7.3
CL541-0701-1	DF1BA- 3EP-2.5RC	5.0	9.6	13.7	14.4	15.1	9.8
CL541-0702-4	DF1BA- 4EP-2.5RC	7.5	12.1	16.2	16.9	17.6	12.3
CL541-0703-7	DF1BA- 5EP-2.5RC	10.0	14.6	18.7	19.4	20.1	14.8
CL541-0704-0	DF1BA- 6EP-2.5RC	12.5	17.1	21.2	21.9	22.6	17.3
CL541-0705-2	DF1BA- 7EP-2.5RC	15.0	19.6	23.7	24.4	25.1	19.8
CL541-0706-5	DF1BA- 8EP-2.5RC	17.5	22.1	26.2	26.9	27.6	22.3
CL541-0707-8	DF1BA- 9EP-2.5RC	20.0	24.6	28.7	29.4	30.1	24.8
CL541-0708-0	DF1BA-10EP-2.5RC	22.5	27.1	31.2	31.9	32.6	27.3
CL541-0709-3	DF1BA-11EP-2.5RC	25.0	29.6	33.7	34.4	35.1	29.8
CL541-0710-2	DF1BA-12EP-2.5RC	27.5	32.1	36.2	36.9	37.6	32.3
CL541-0711-5	DF1BA-13EP-2.5RC	30.0	34.6	38.7	39.4	40.1	34.8
CL541-0713-0	DF1BA-15EP-2.5RC	35.0	39.6	43.7	44.4	45.1	39.8

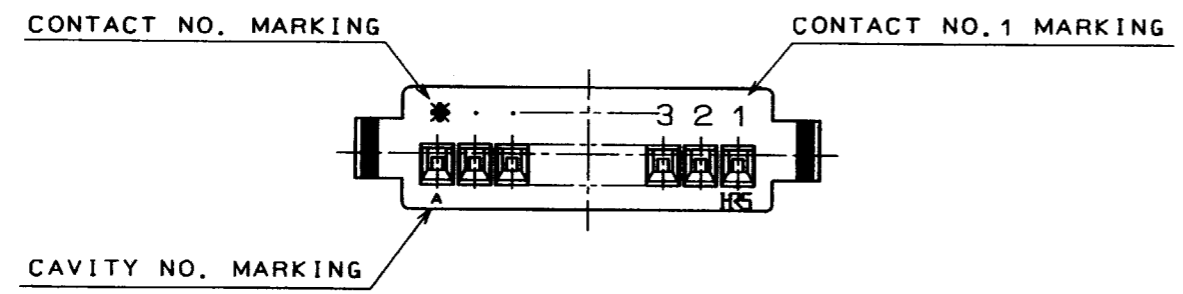

NOTES 1: CONCAVE PORTION TO PREVENT CONNECTOR MISINSERTION SHALL BE APPLIED ONE AT THE CENTER FOR 2 CONTACTS, TWO AT BOTH ENDS FOR 3 TO 6 CONTACTS AND 3 FOR ANOTHER NUMBER OF CONTACT AS THE FIGURE SHOWN.

2: WHEN YOU MOUNT DF1BA RELAY SOCKET ON A PANEL, PLEASE TAKE NOTE OF DIMENSIONS 'a', INDICATED IN THE TABLE ABOVE. BECAUSE THE CUT-OUT DIMENSION DEPENDS ON PANEL THICKNESS. THE PANEL CUT-OUT SHALL BE FREE FROM BURR.

TO

1 POLYAMIDE		NATURAL(WHITE) UL94V-0				
NO.	MATERIAL	FINISH, REMARKS	NO.	MATERIAL	FINISH, REMARKS	
CODE NO. (OLD)		DRAWN	DESIGNED	CHECKED	APPROVED	RELEASED
		R. SASAKI	M. Tanaka	J. Oma	H. Yamamoto	
		951011	95.10.23	95.10.23	95.10.23	
DRAWING NO.		PART NO.				
EDC3-160595		DF1BA- * EP-2.5RC				
SCALE		CODE NO.		CODE NO. SHALL BE IN ACCORDANCE WITH TABLE.		
2:1						
UNITS						
mm		HRS HIROSE ELECTRIC CO., LTD.		1/1		