

May.1.2023 Copyright 2023 HIROSE ELECTRIC CO., LTD. All Rights Reserved.
In case of consideration for using Automotive equipment / device which demand high reliability, kindly contact our sales window correspondents.

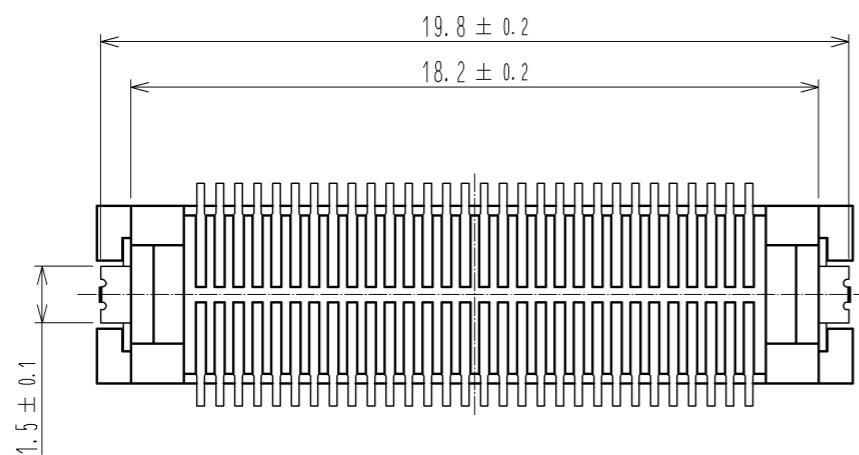

RECOMMENDED PATTERN

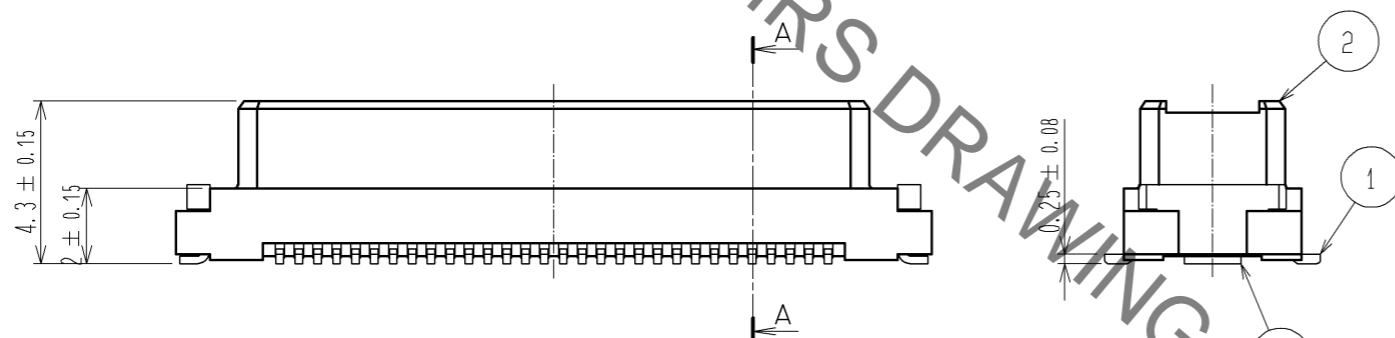
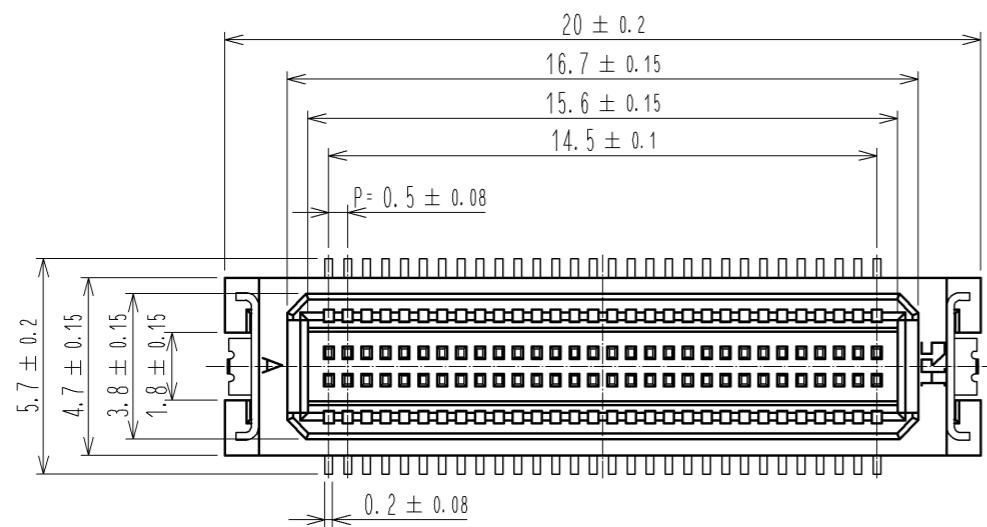
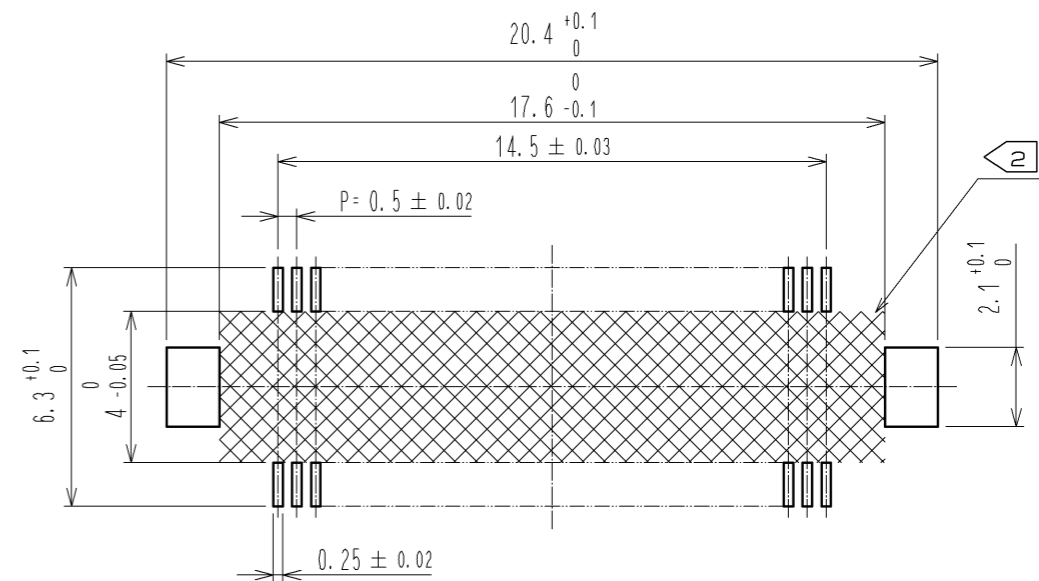

A-A (10 : 1)

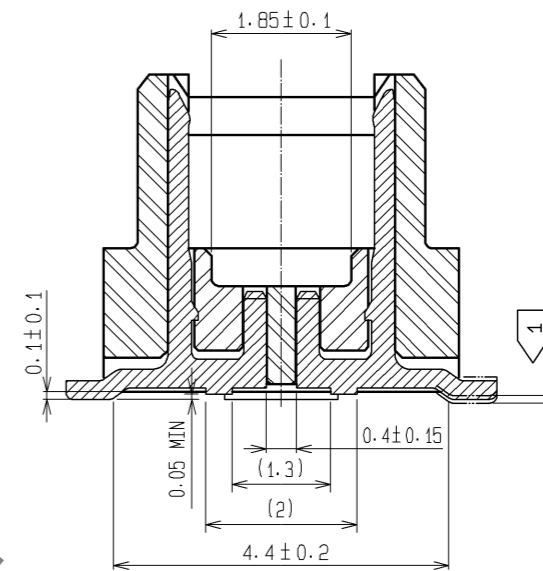

- NOTES 1 LEAD CO-PLANARITY INCLUDE REINFORCED METAL FITTINGS SHALL BE 0.1mm MAX .
2 WHEN A PART MARKED WITH HAS A PATTERN BUT NO RESIST ON IT. TAKE CARE TO PREVENT THE CONNECTOR FROM TOUCHING IT.

MATED HIGHT (h)	RECEPTACLE NO. (mm)	
	DF17#(3.0)-60DS-0.5V(57)	DF17#(4.0)-60DS-0.5V(57)
HEADER NO.	5	6
DF17B(2.0)-60DP-0.5V(58)		

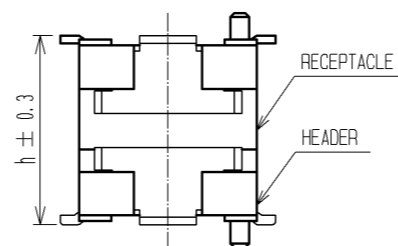

NO.	MATERIAL	FINISH . REMARKS	NO.	MATERIAL	FINISH . REMARKS
2	POLYAMIDE (PA6T)	WHITE BEIGE . UL94V-0	7	PS	PLASTIC REEL . BLACK
1	PHOSPHER BRONZE	CONTACT AREA:GOLD PLATED 0.1#m min LEAD AREA:TIN PLATED 1#m min UNDER PLATING:NICKEL PLATED 1#m min	6	POLYESTER	CLEAR (COVER TAPE)
			5	A-PET	CLEAR(EMBOSSD CARRIER TAPE)
			4	POLYIMIDE	BROWN(HEAT-RESISTANCE TAPE)
			3	PHOSPHER BRONZE	TIN PLATED : 1#m min UNDER PLATING:NICKEL PLATED 1#m min

UNITS	SCALE	COUNT	DESCRIPTION OF REVISIONS	DESIGNED	CHECKED	DATE
mm	5 : 1	△				

APPROVED : KH. IKEDA	09.06.12	DRAWING NO.	EDC3-161740-04
CHECED : AR. TAKAHASHI	09.06.12	PART NO.	DF17B(2.0)-60DP-0.5V(58)
DESIGNED : TY. YAMASAKI	09.06.09	CODE NO.	CL683-0106-8-58
DRAWN : TY. YAMASAKI	09.06.09		

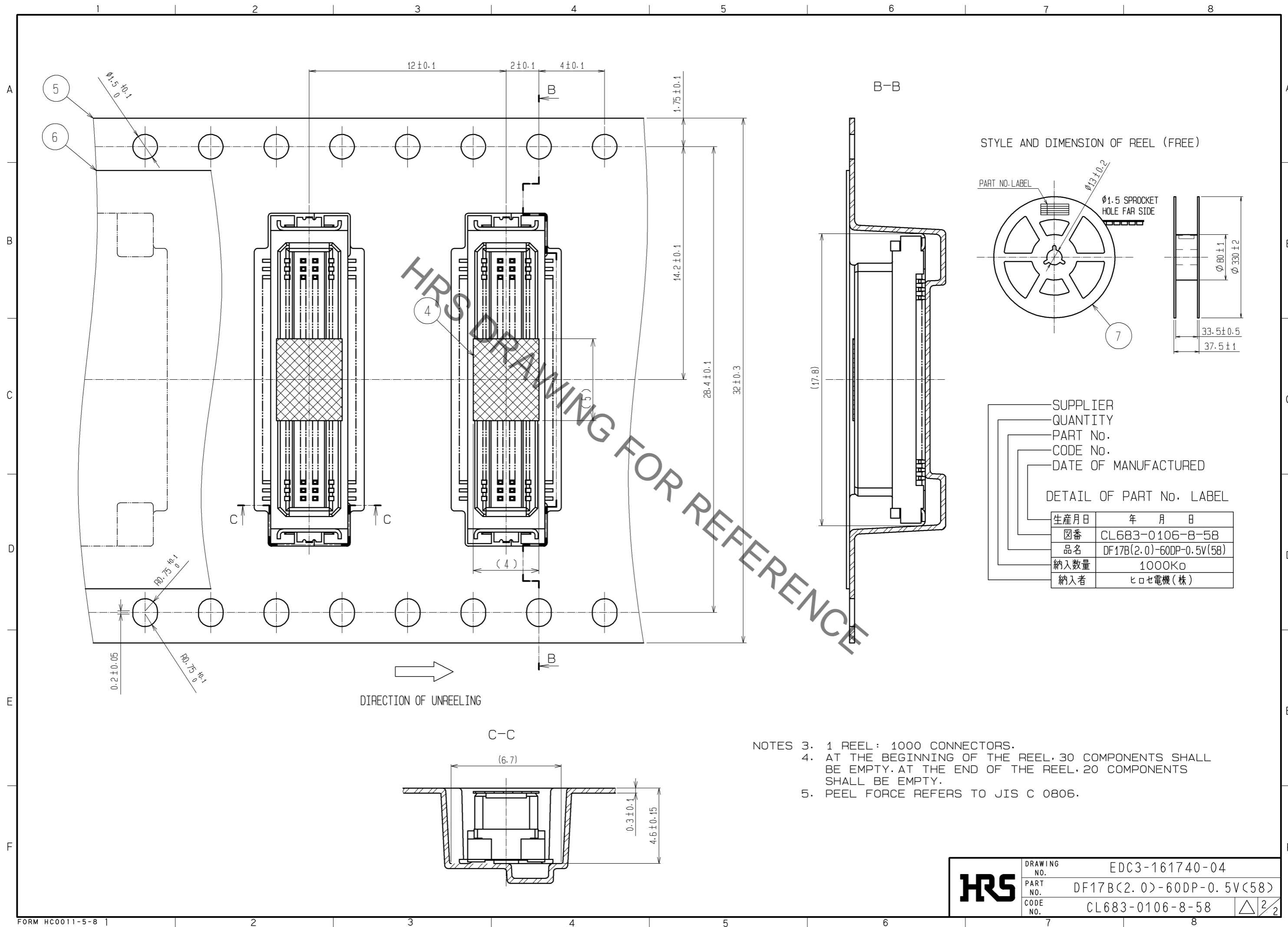

HRS	DRAWING NO.	EDC3-161740-04	
	PART NO.	DF17B(2.0)-60DP-0.5V(58)	
	CODE NO.	CL683-0106-8-58	△ 2/2