

| REVISIONS | | | | | |
|-----------|-----|---------------------------|-----------|-----|------|
| P | LTR | DESCRIPTION | DATE | DWN | APVD |
| C1 | | REVISED PER ECN-22-145617 | 23JUN2022 | AP | MT |

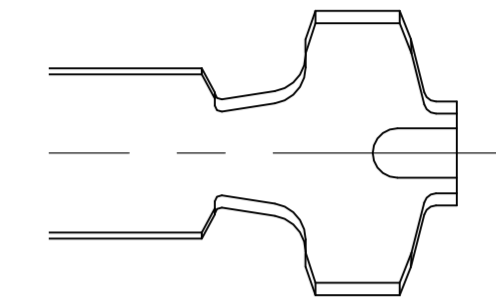

-13 ONLY

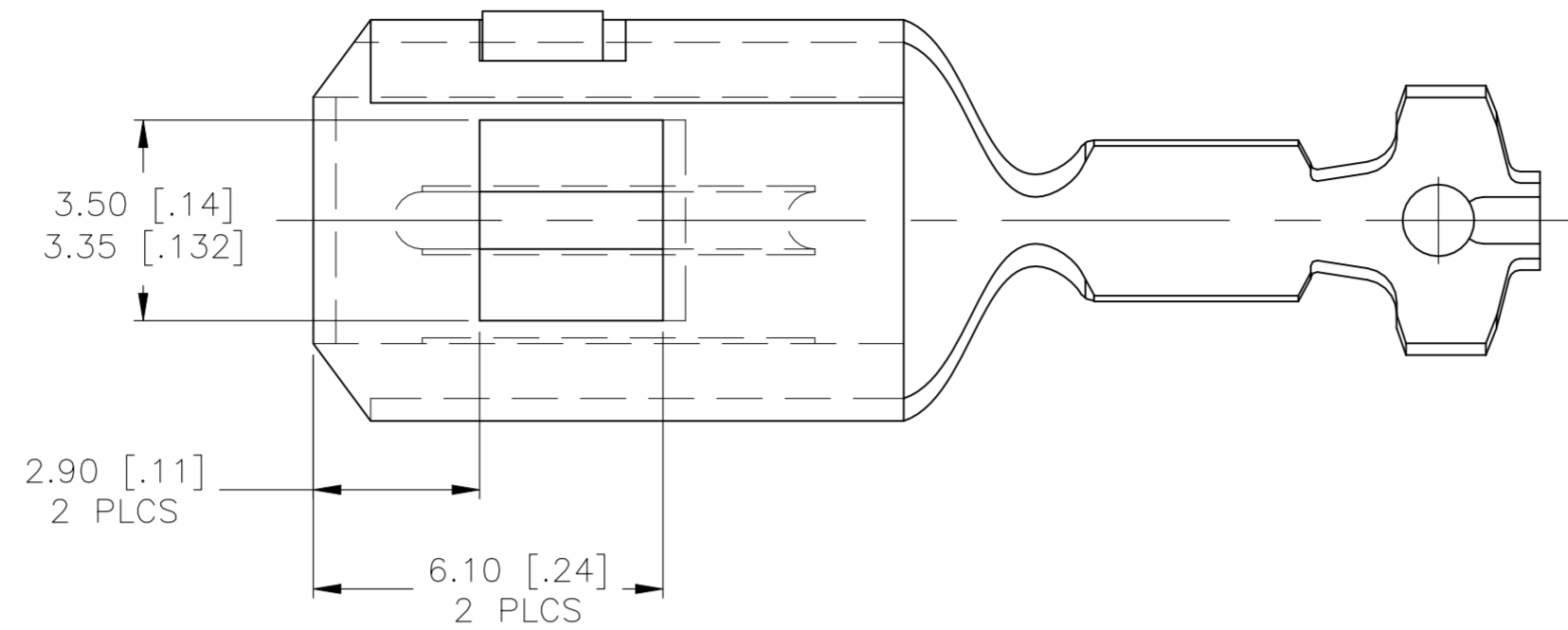
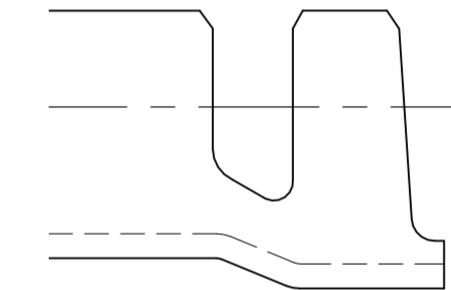
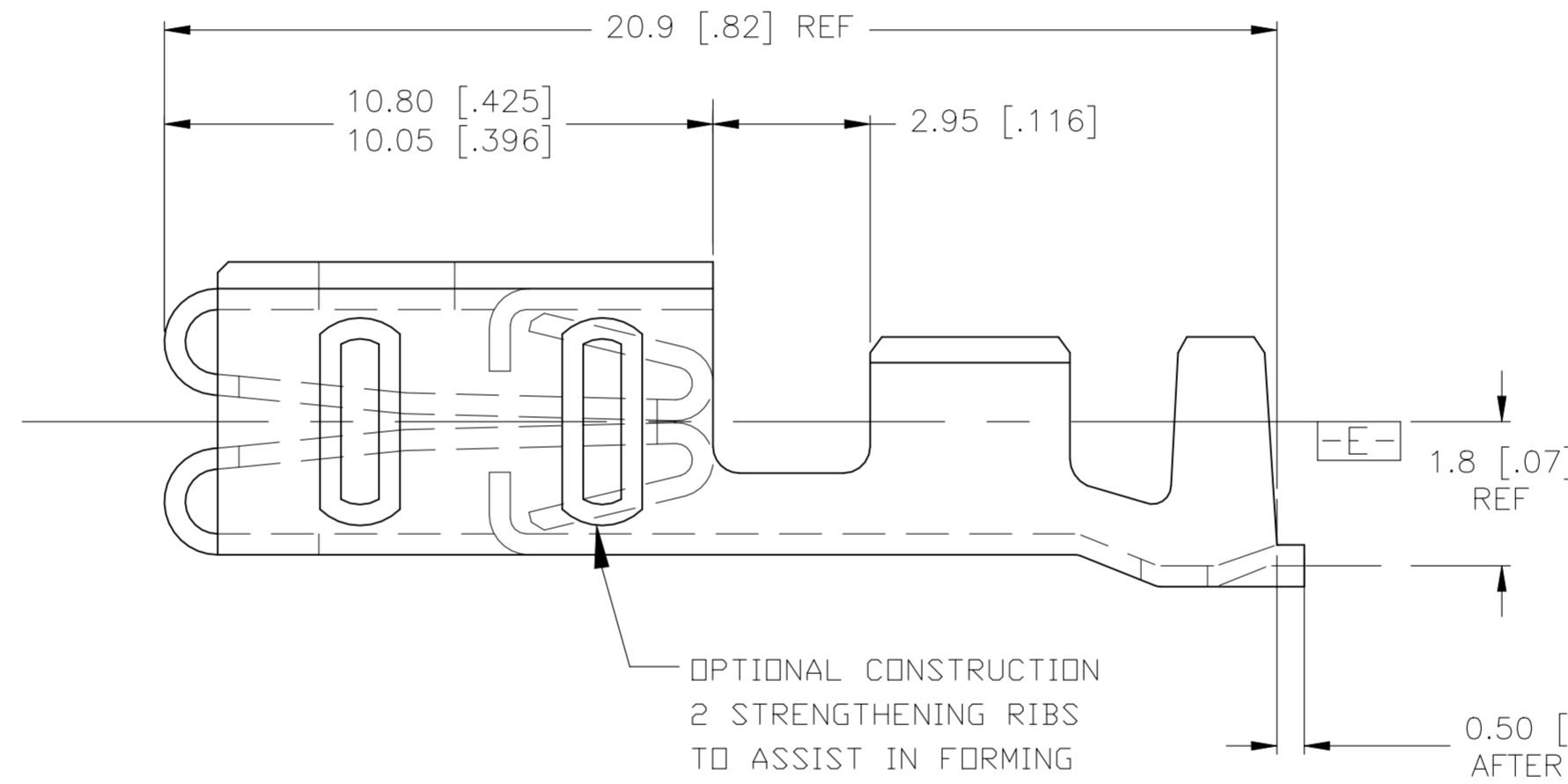

-13 ONLY

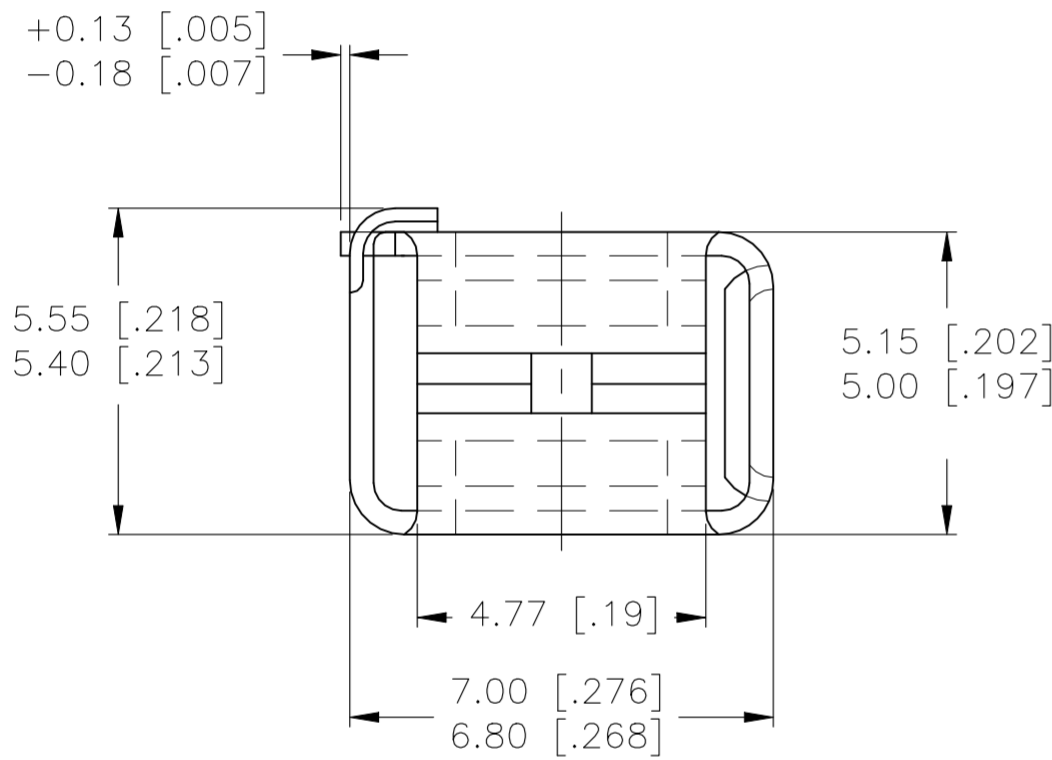

MATERIAL:

- A. N/A
- B. N/A
- C. UNS-C26000 BRASS
- D. BERYLLIUM COPPER ALLOY UNS-C17410.
- E. UNS-C19400 COPPER

FINISH: HOT TIN DIP PRE TIN STRIP

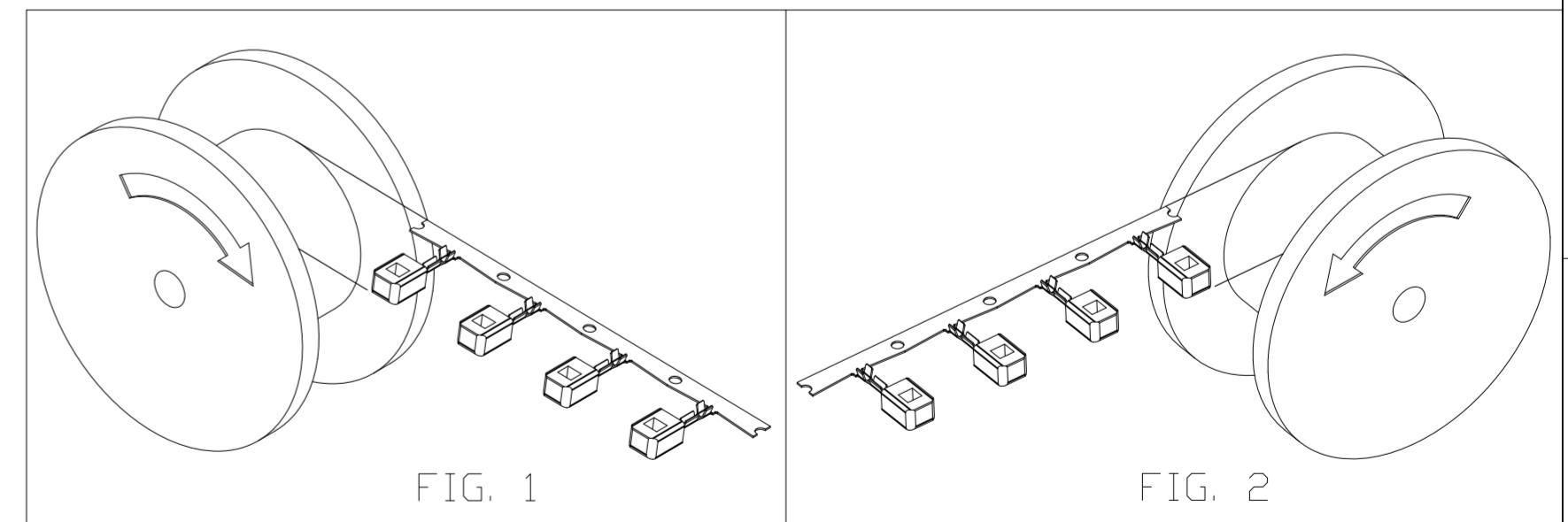

FIG. 1

FIG. 2

| | | | | | |
|-----------|-------|---------------------------|---------------|-------------------|-------|
| 14 | LIGHT | - | E8EB-14474 UA | 1-1438243-1 | E |
| 14 | HEAVY | 1438243-9 | E8EB 14474 VA | 1438243-2 | C |
| 18 | HEAVY | 1-1438243-2 | E7EB 14474 EA | 1438243-1 | C |
| WIRE GAGE | DUTY | TE P/N REWOUND SEE FIG. 2 | FORD P/N | TE P/N SEE FIG. 1 | MAT'L |

OBSOLETE

| DIMENSIONS: | | TOLERANCES UNLESS OTHERWISE SPECIFIED: | | WINDING | |
|-------------|--|--|-------------|--|--|
| mm | | 0 PLC ± - | 1 PLC ± 0.2 | THIS DRAWING IS A CONTROLLED DOCUMENT. | |
| | | 2 PLC ± 0.15 | 3 PLC ± - | DWN JR BUSSARD 03 JUNE 2003 | |
| MATERIAL | | 4 PLC ± - | ANGLES ± 3° | CHK DM REVAK 03 JUNE 2003 | |
| SEE NOTES | | FINISH | | APVD DM REVAK 03 JUNE 2003 | |
| SEE NOTES | | SEE NOTES | | PRODUCT SPEC | |
| MATERIAL | | FINISH | | APPLICATION SPEC | |
| SEE NOTES | | SEE NOTES | | WEIGHT 0 | |
| SEE NOTES | | SEE NOTES | | SIZE A2 | |
| SEE NOTES | | SEE NOTES | | CAGE CODE 00779 | |
| SEE NOTES | | SEE NOTES | | DRAWING NO C=1438243 | |
| SEE NOTES | | SEE NOTES | | RESTRICTED TO - | |
| SEE NOTES | | SEE NOTES | | CUSTOMER DRAWING | |
| SEE NOTES | | SEE NOTES | | SCALE 4:1 | |
| SEE NOTES | | SEE NOTES | | SHEET 1 of 1 | |
| SEE NOTES | | SEE NOTES | | REV C1 | |