

BASE CAGE DETAILS

1000173242

SHOWN

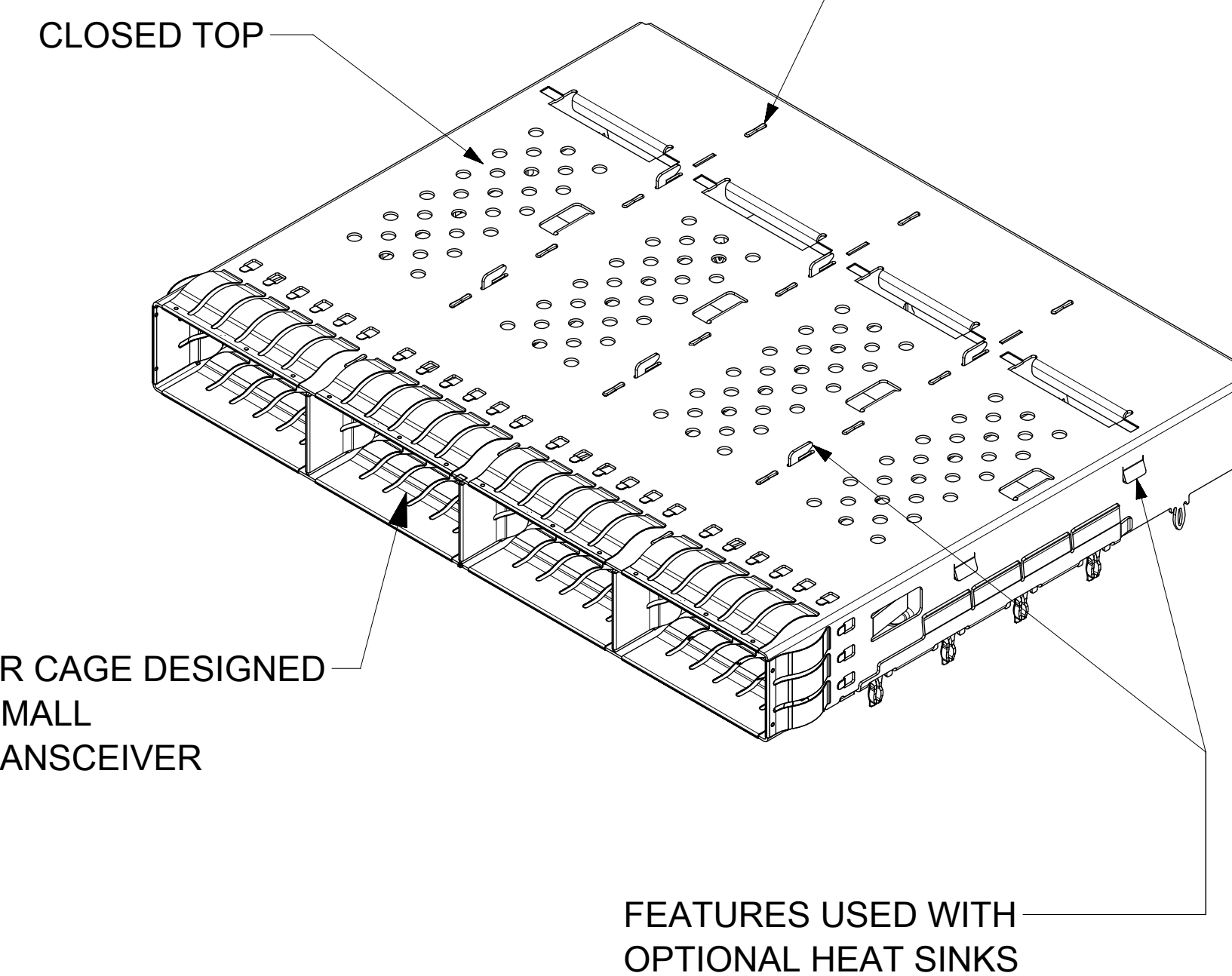
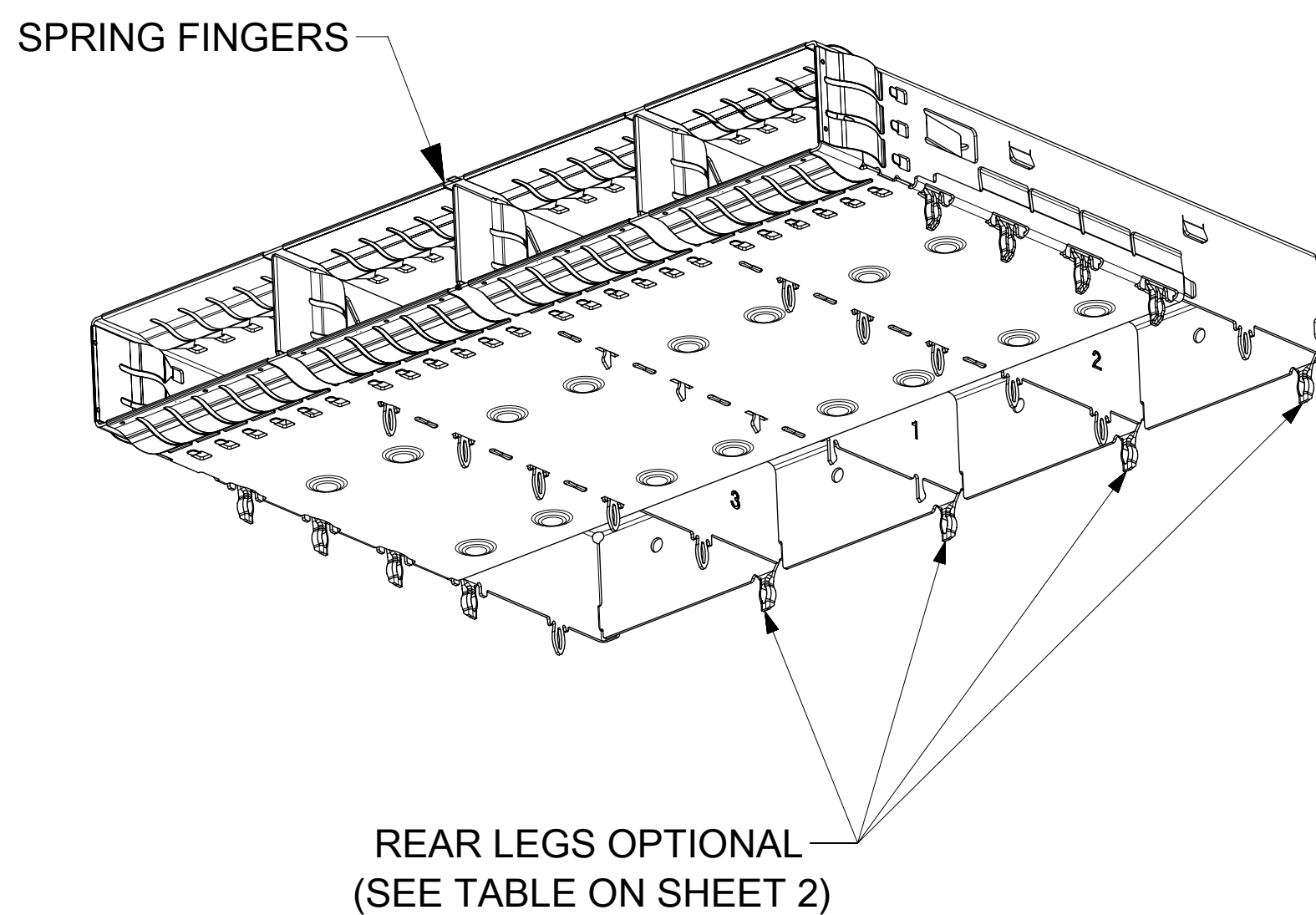
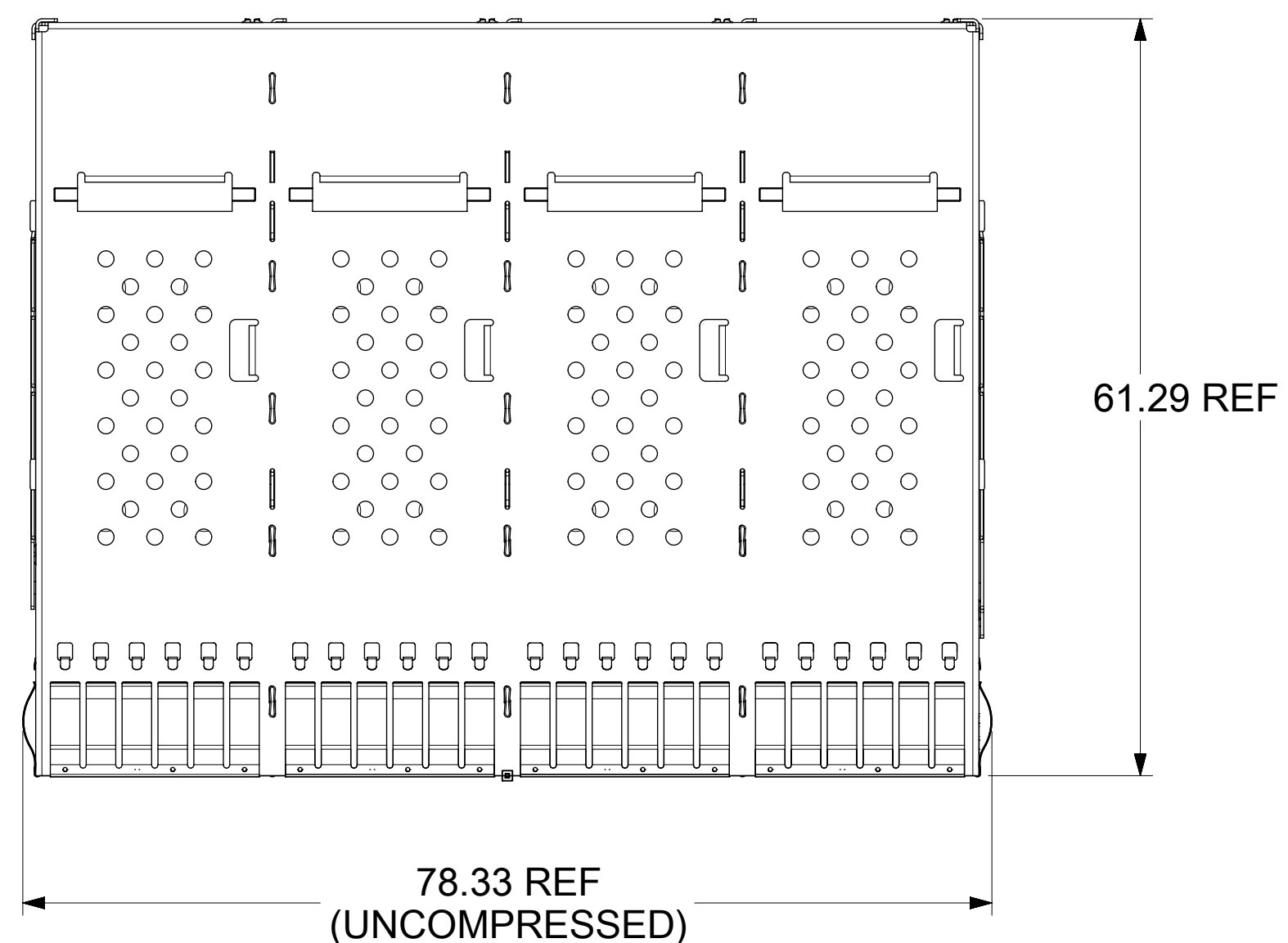

DIMENSIONS OF EACH INNER CAGE DESIGNED
TO FUNCTION WITH QUAD SMALL
FORM-FACTOR (zQSFP+) TRANSCEIVER

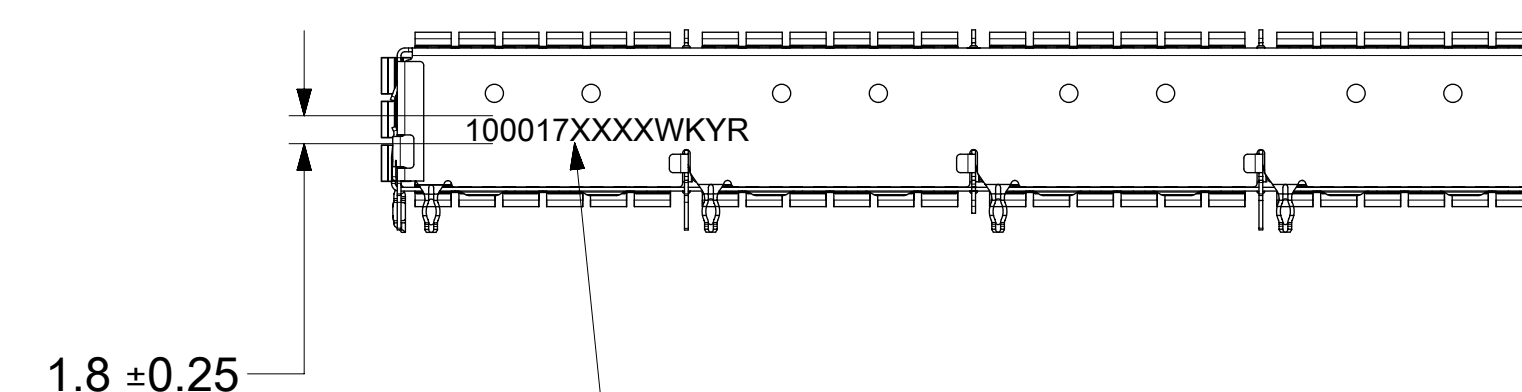
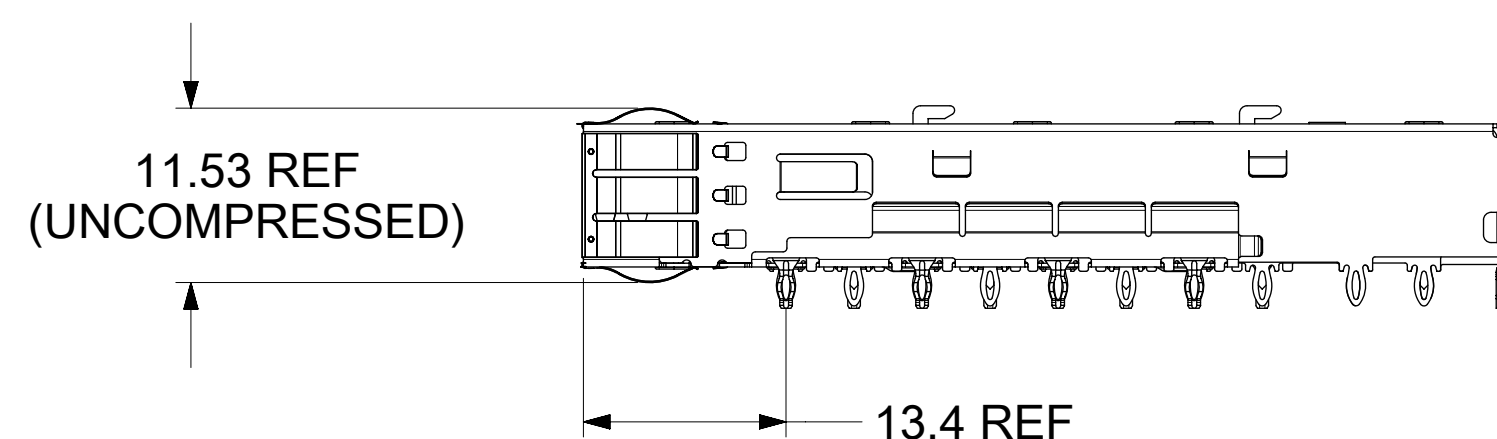
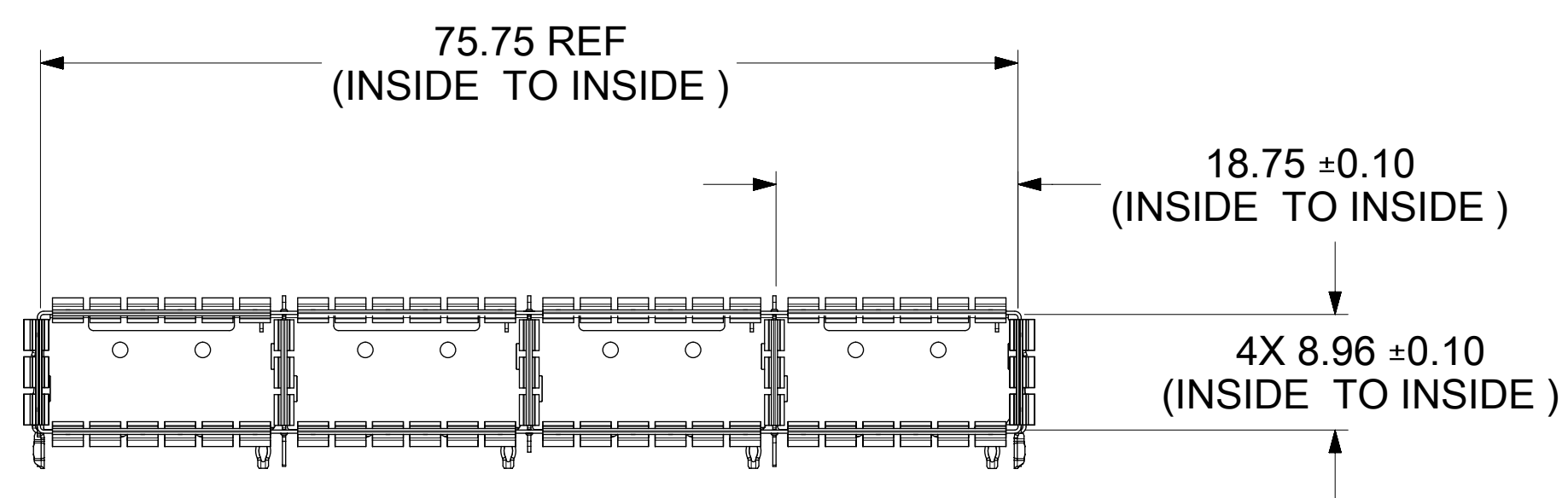

P/N AND WEEK/YEAR DATE CODE TO BE PRINTED ON
BACK OF COMPLETED CAGE ASSEMBLY APPROXIMATELY AS SHOWN.
SEE TABLE BELOW FOR DATE CODE INFORMATION.

- NOTES:
- MATERIAL: CAGE: STAINLESS STEEL
CENTER WALLS: STAINLESS STEEL
SPRING FINGERS: STAINLESS STEEL
HEAT SINKS: NICKEL PLATED ALUMINUM
HEAT SINK CLIP: STAINLESS STEEL
LIGHT PIPES: POLYCARBONATE (UL 94-V-0)
 - DIMENSIONS MARKED ∇ ARE CRITICAL TO FUNCTION OF THE PART AND MUST BE INSPECTED
 - DRAWING APPLIES TO ALL P/N'S SHOWN ON PAGE 3
 - DURING FINAL INSPECTION, CAGE LEG LOCATIONS AND STRAIGHTNESS MUST BE CHECKED USING APPROPRIATE GO - NO GO GAGE
 - DURING FINAL INSPECTION, CAGE MUST BE INSPECTED TO MAKE SURE LEG CONFIGURATIONS AND PART NUMBERS ARE CORRECT, USE SHEETS 3, 4 AND 5
 - PARTS TO BE INSPECTED PER MOLEX COSMETIC SPEC WI-HP-7-2774 (CLASS B UNLESS OTHERWISE SPECIFIED)
 - PRESS-FIT LEGS 2.44 LONG -
1.57 MINIMUM PCB THICKNESS FOR SINGLE SIDED USE.
3.00 MINIMUM PCB THICKNESS FOR BELLY TO BELLY USE.
 - NO RoHS EXEMPTIONS
 - WELD SPOTS MAY SHOW SLIGHT MATERIAL DISCOLORATION.

| WEEK/YEAR DATE CODE TABLE | | | | | | | | | | | | | | | | | | | |
|--|--|--|------------------------|--|----------------|--------------------------|---------------------------------------|-----------------|-----------------------------|-------------------|----------------|---------------|----------------|----------------|---------------------|--|--------------------|--|----------------|
| WK | WEEK OF THE YEAR 01 THRU 52 (EXAMPLE: 01= FIRST WEEK OF YEAR 52= LAST WEEK OF YEAR) | | | | | | | | | | | | | | | | | | |
| YR | 22, 23, 24 ETC.. (EXAMPLE: YEAR 2022= 22) | | | | | | | | | | | | | | | | | | |
| THIS DRAWING CONTAINS INFORMATION THAT IS PROPRIETARY TO MOLEX ELECTRONIC TECHNOLOGIES, LLC AND SHOULD NOT BE USED WITHOUT WRITTEN PERMISSION | | | | | | | | | | | | | | | | | | | |
| FUNCTIONAL SYMBOLS | <table border="1"> <tr> <th>DIMENSION UNITS</th> <th>SCALE</th> </tr> <tr> <td>$\nabla_A = 0$</td> <td>mm 2:1</td> </tr> <tr> <td>$\nabla_C = 0$</td> <td>GENERAL TOLERANCES (UNLESS SPECIFIED)</td> </tr> <tr> <td>$\nabla_D = 0$</td> <td>ANGULAR TOL $\pm 1.0^\circ$</td> </tr> <tr> <td></td> <td>4 PLACES \pm</td> </tr> <tr> <td></td> <td>3 PLACES \pm</td> </tr> <tr> <td></td> <td>2 PLACES ± 0.13</td> </tr> <tr> <td></td> <td>1 PLACE ± 0.25</td> </tr> <tr> <td></td> <td>0 PLACES \pm</td> </tr> </table> | DIMENSION UNITS | SCALE | $\nabla_A = 0$ | mm 2:1 | $\nabla_C = 0$ | GENERAL TOLERANCES (UNLESS SPECIFIED) | $\nabla_D = 0$ | ANGULAR TOL $\pm 1.0^\circ$ | | 4 PLACES \pm | | 3 PLACES \pm | | 2 PLACES ± 0.13 | | 1 PLACE ± 0.25 | | 0 PLACES \pm |
| DIMENSION UNITS | SCALE | | | | | | | | | | | | | | | | | | |
| $\nabla_A = 0$ | mm 2:1 | | | | | | | | | | | | | | | | | | |
| $\nabla_C = 0$ | GENERAL TOLERANCES (UNLESS SPECIFIED) | | | | | | | | | | | | | | | | | | |
| $\nabla_D = 0$ | ANGULAR TOL $\pm 1.0^\circ$ | | | | | | | | | | | | | | | | | | |
| | 4 PLACES \pm | | | | | | | | | | | | | | | | | | |
| | 3 PLACES \pm | | | | | | | | | | | | | | | | | | |
| | 2 PLACES ± 0.13 | | | | | | | | | | | | | | | | | | |
| | 1 PLACE ± 0.25 | | | | | | | | | | | | | | | | | | |
| | 0 PLACES \pm | | | | | | | | | | | | | | | | | | |
| DIVISIONAL SYMBOLS | <table border="1"> <tr> <th>DRAFT WHERE APPLICABLE MUST REMAIN WITHIN DIMENSIONS</th> <th>THIRD ANGLE PROJECTION</th> <th>DRAWING</th> <th>SERIES</th> <th>MATERIAL NUMBER</th> <th>CUSTOMER</th> <th>SHEET NUMBER</th> </tr> <tr> <td></td> <td></td> <td>D-SIZE</td> <td>100017</td> <td>SEE P/N TABLE</td> <td>GENERAL MARKET</td> <td>1 OF 8</td> </tr> </table> | DRAFT WHERE APPLICABLE MUST REMAIN WITHIN DIMENSIONS | THIRD ANGLE PROJECTION | DRAWING | SERIES | MATERIAL NUMBER | CUSTOMER | SHEET NUMBER | | | D-SIZE | 100017 | SEE P/N TABLE | GENERAL MARKET | 1 OF 8 | | | | |
| DRAFT WHERE APPLICABLE MUST REMAIN WITHIN DIMENSIONS | THIRD ANGLE PROJECTION | DRAWING | SERIES | MATERIAL NUMBER | CUSTOMER | SHEET NUMBER | | | | | | | | | | | | | |
| | | D-SIZE | 100017 | SEE P/N TABLE | GENERAL MARKET | 1 OF 8 | | | | | | | | | | | | | |
| CURRENT REV DESC: SEE REVISION TABLE | | | | | | | | | | | | | | | | | | | |
| <table border="1"> <tr> <td>EC NO: 698865</td> <td>2022/02/17</td> </tr> <tr> <td>DRWN: KRISHH1</td> <td>2022/03/10</td> </tr> <tr> <td>CHK'D: TKUMARKC</td> <td>2022/03/21</td> </tr> <tr> <td>APPR: JCHIANG</td> <td></td> </tr> <tr> <td>INITIAL REVISION:</td> <td></td> </tr> <tr> <td>DRWN: KRISHH1</td> <td>2022/02/17</td> </tr> <tr> <td>APPR: JCHIANG</td> <td>2022/03/21</td> </tr> </table> | | EC NO: 698865 | 2022/02/17 | DRWN: KRISHH1 | 2022/03/10 | CHK'D: TKUMARKC | 2022/03/21 | APPR: JCHIANG | | INITIAL REVISION: | | DRWN: KRISHH1 | 2022/02/17 | APPR: JCHIANG | 2022/03/21 | | | | |
| EC NO: 698865 | 2022/02/17 | | | | | | | | | | | | | | | | | | |
| DRWN: KRISHH1 | 2022/03/10 | | | | | | | | | | | | | | | | | | |
| CHK'D: TKUMARKC | 2022/03/21 | | | | | | | | | | | | | | | | | | |
| APPR: JCHIANG | | | | | | | | | | | | | | | | | | | |
| INITIAL REVISION: | | | | | | | | | | | | | | | | | | | |
| DRWN: KRISHH1 | 2022/02/17 | | | | | | | | | | | | | | | | | | |
| APPR: JCHIANG | 2022/03/21 | | | | | | | | | | | | | | | | | | |
| <table border="1"> <tr> <td colspan="2" style="text-align: center;">molex</td> </tr> <tr> <td colspan="2" style="text-align: center;">ZQSFP+ 1X4 GANGED CAGE ASSY'S W/ SS TAB TYPE SPRING FINGER H/S & L/P OPTIONS</td> </tr> <tr> <td colspan="2" style="text-align: center;">PRODUCT CUSTOMER DRAWING</td> </tr> <tr> <td>DOCUMENT NUMBER</td> <td>DOC TYPE DOC PART REVISION</td> </tr> <tr> <td style="text-align: center;">1000173200</td> <td style="text-align: center;">PSD ASY A</td> </tr> </table> | | molex | | ZQSFP+ 1X4 GANGED CAGE ASSY'S W/ SS TAB TYPE SPRING FINGER H/S & L/P OPTIONS | | PRODUCT CUSTOMER DRAWING | | DOCUMENT NUMBER | DOC TYPE DOC PART REVISION | 1000173200 | PSD ASY A | | | | | | | | |
| molex | | | | | | | | | | | | | | | | | | | |
| ZQSFP+ 1X4 GANGED CAGE ASSY'S W/ SS TAB TYPE SPRING FINGER H/S & L/P OPTIONS | | | | | | | | | | | | | | | | | | | |
| PRODUCT CUSTOMER DRAWING | | | | | | | | | | | | | | | | | | | |
| DOCUMENT NUMBER | DOC TYPE DOC PART REVISION | | | | | | | | | | | | | | | | | | |
| 1000173200 | PSD ASY A | | | | | | | | | | | | | | | | | | |

CAGE ASSEMBLY OPTIONS

1000173544

SHOWN

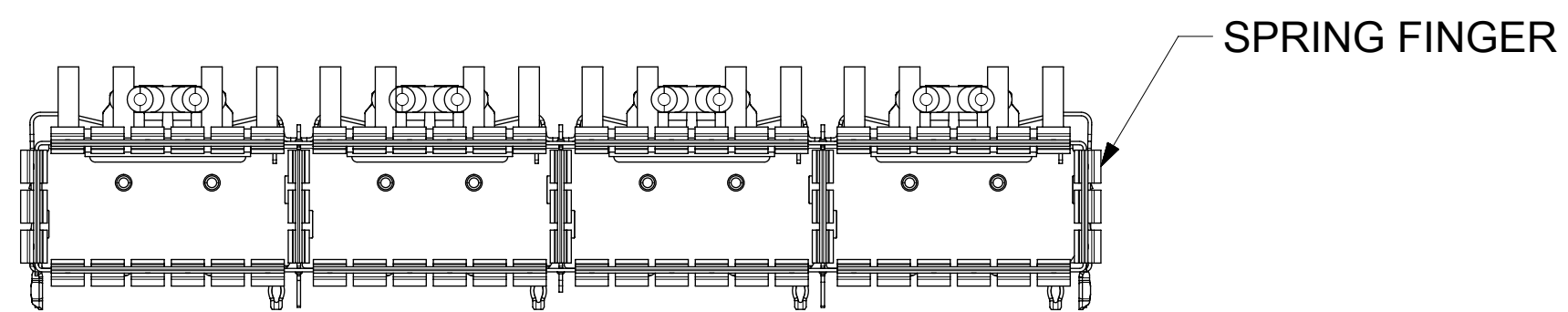
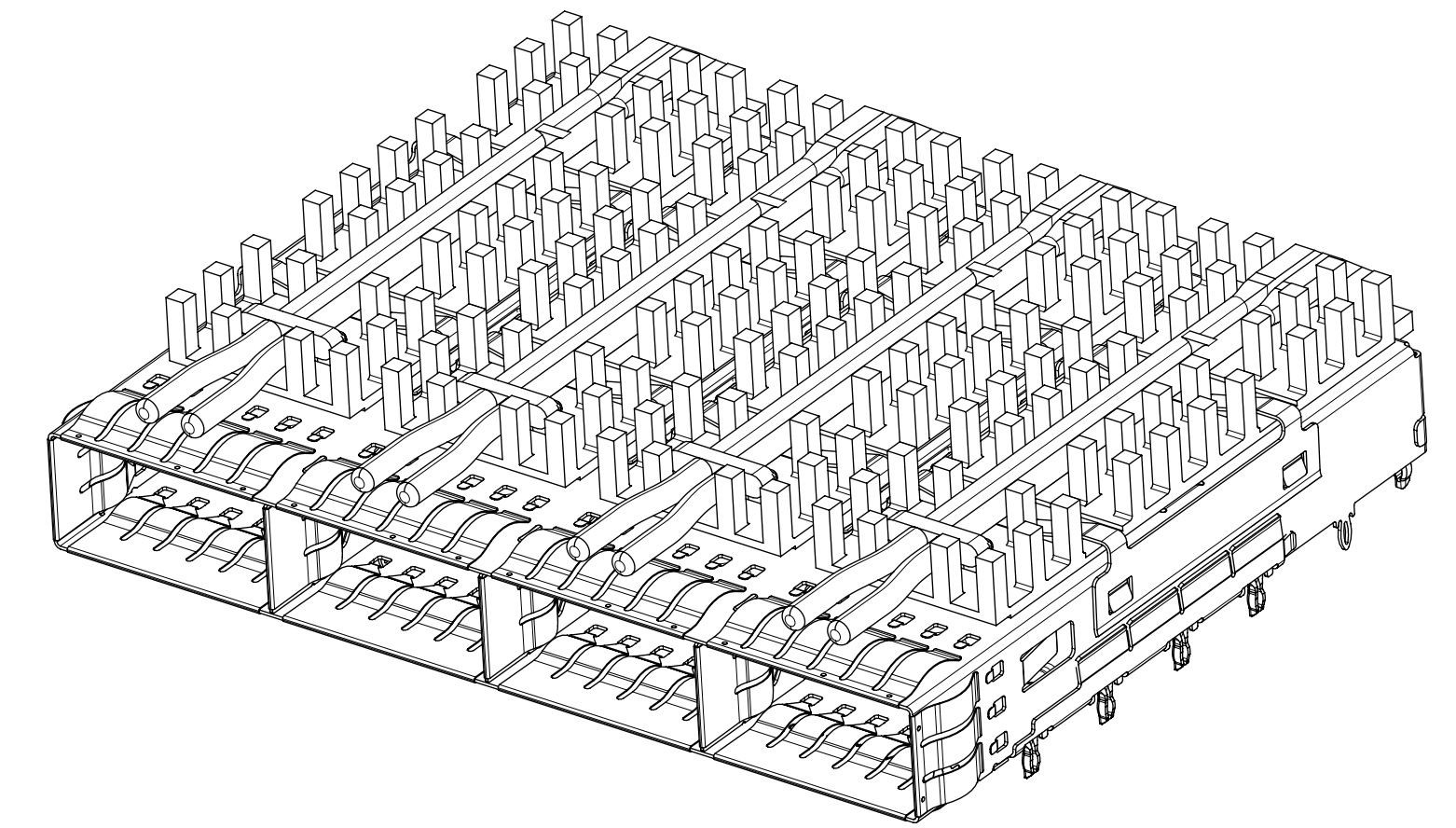
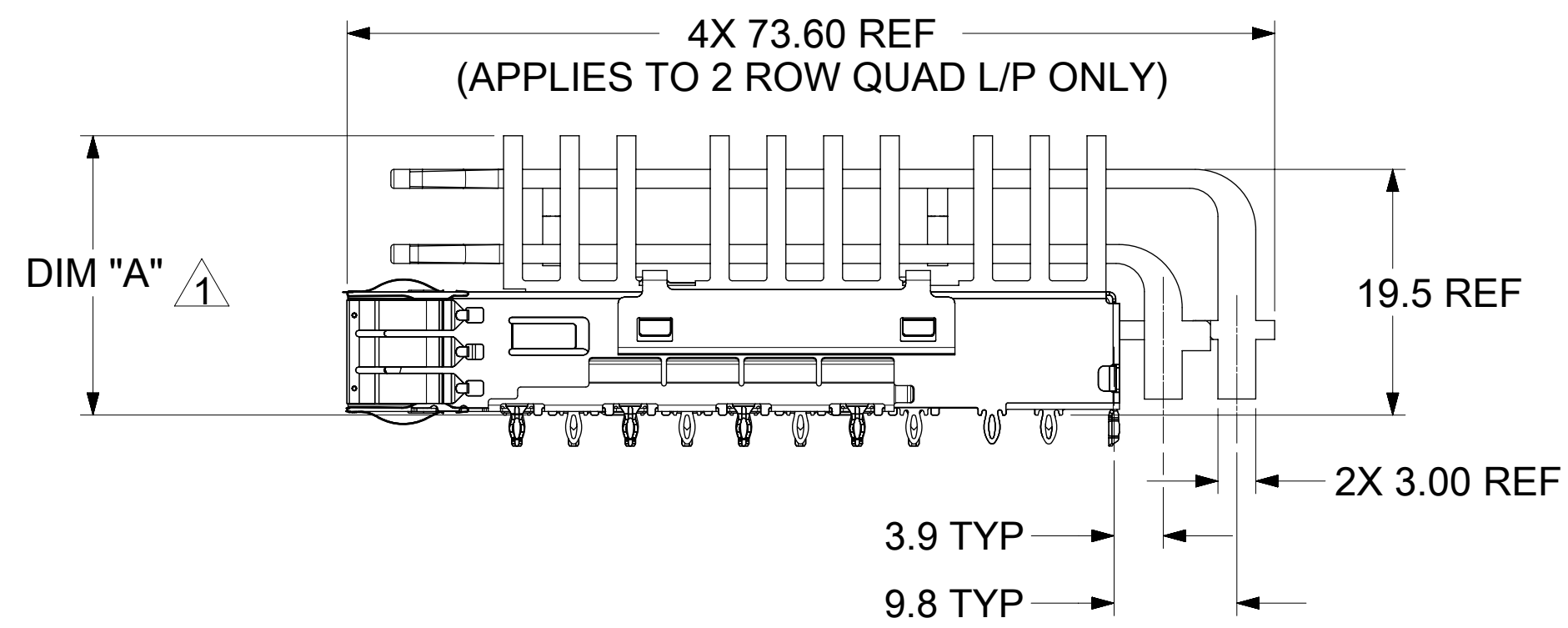
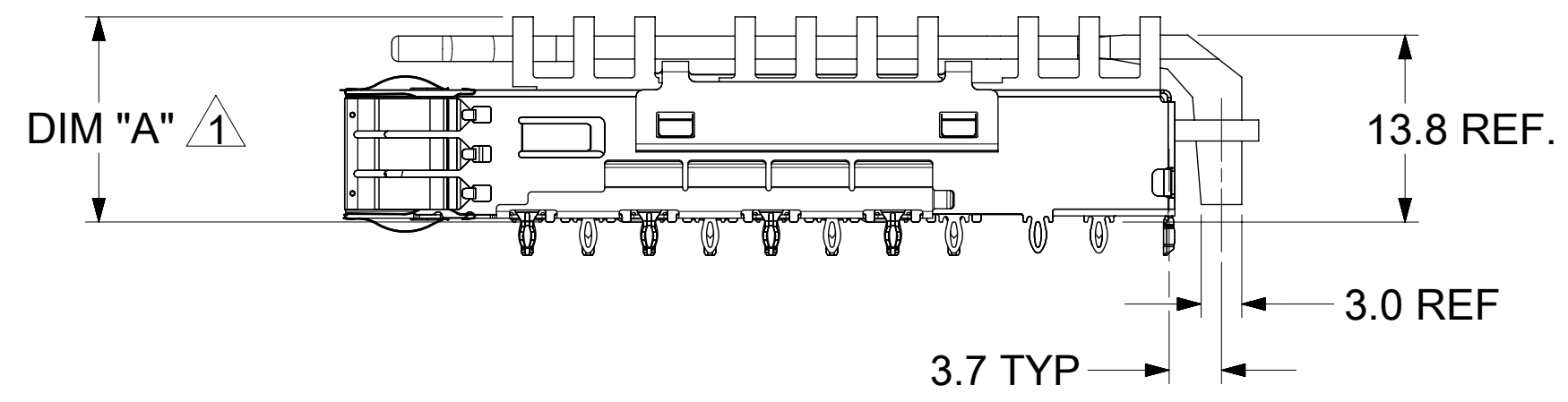
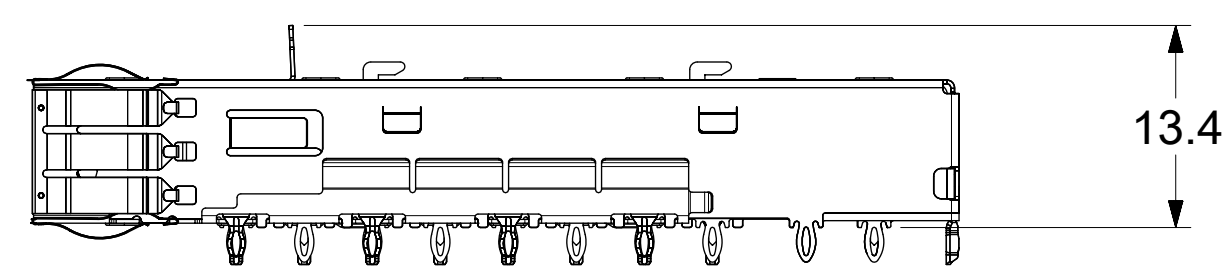
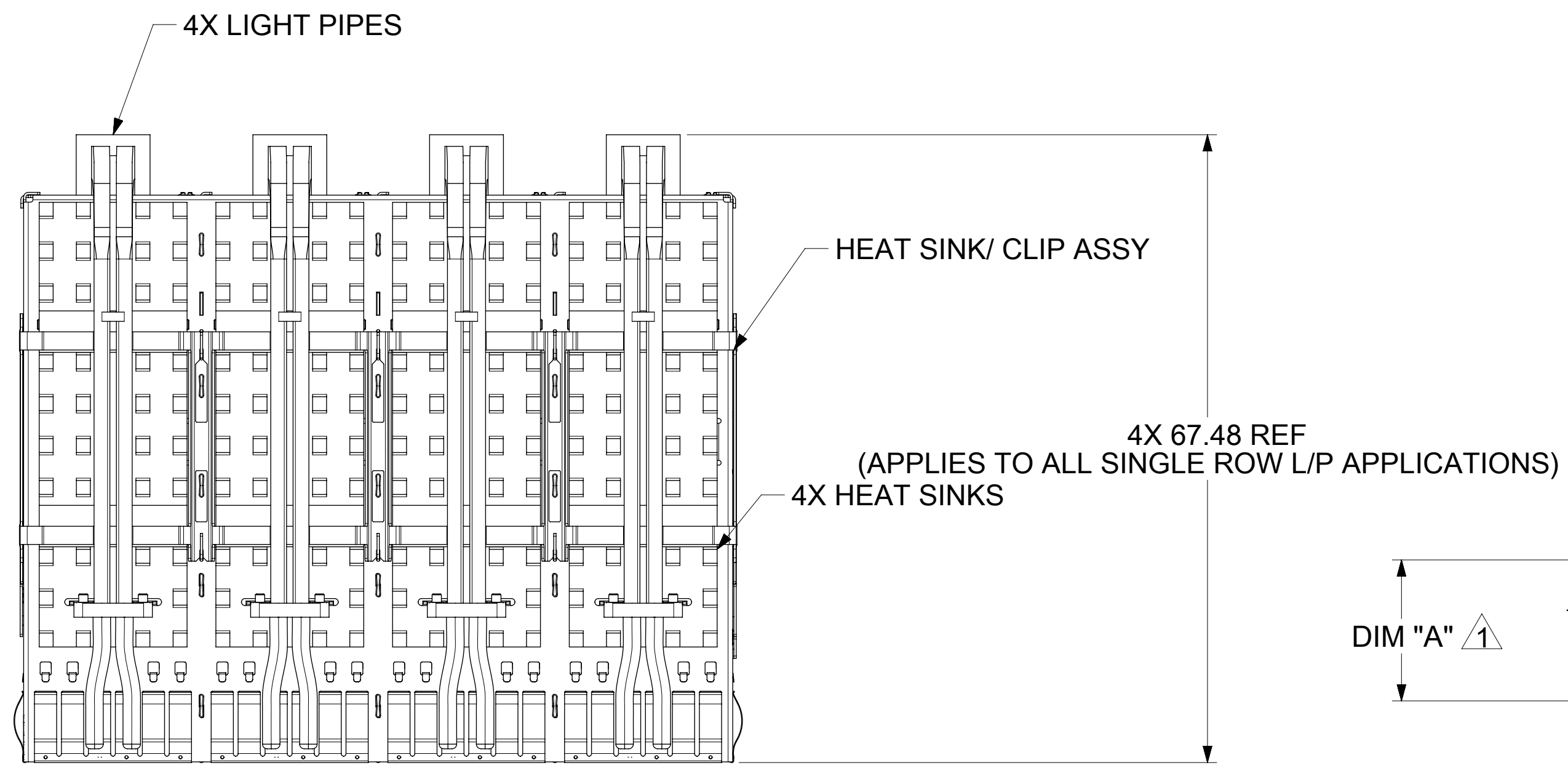

| OVERALL HEAT SINK HEIGHT | DIM "A" |
|--------------------------|----------|
| PCI | 13.7 REF |
| SAN | 16.0 REF |
| NET | 23.0 REF |

\triangle HEIGHT OF HEAT SINK WITH MODULE INSERTED.
DIMENSION MAY BE LESS DUE TO MODULE AND HEAT SINK VARIATIONS

HEATSINK AND LIGHT PIPE COMBINATIONS

HEATSINK
USED
WITHOUT
LIGHTPIPE

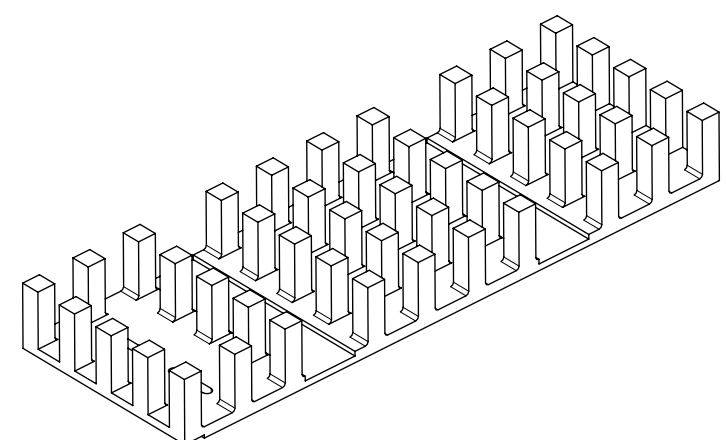

SINGLE / DUAL LIGHT PIPE

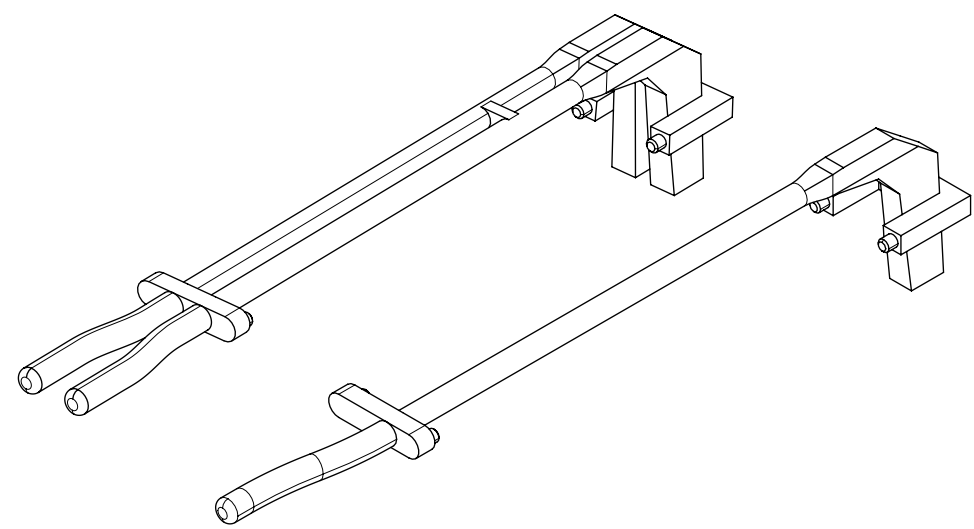

HEATSINK

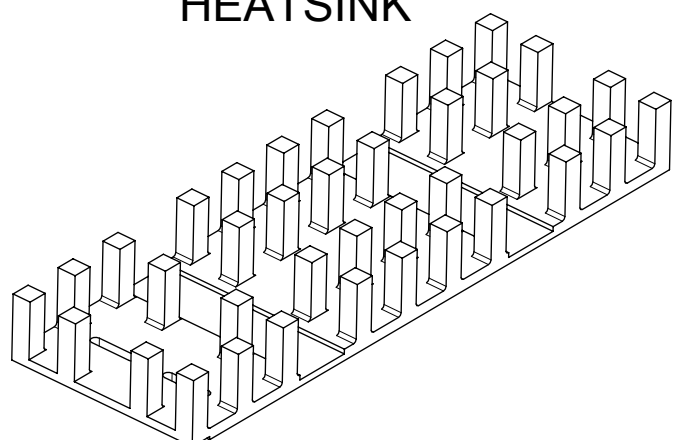

QUAD LIGHT PIPE

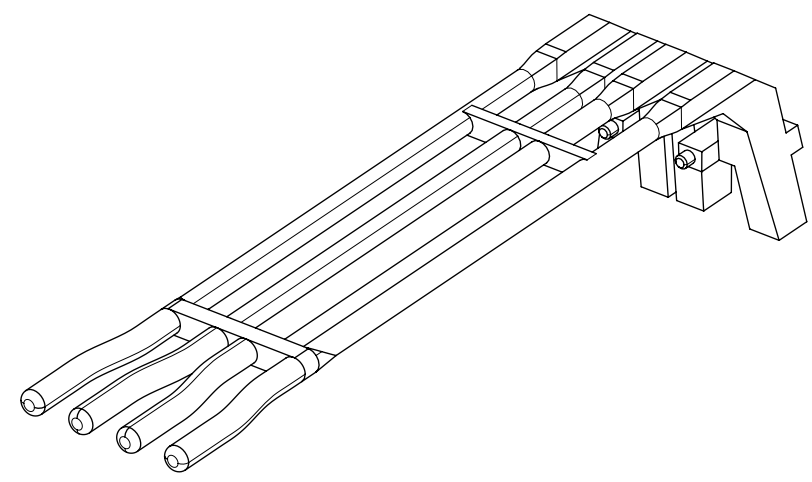

HEATSINK

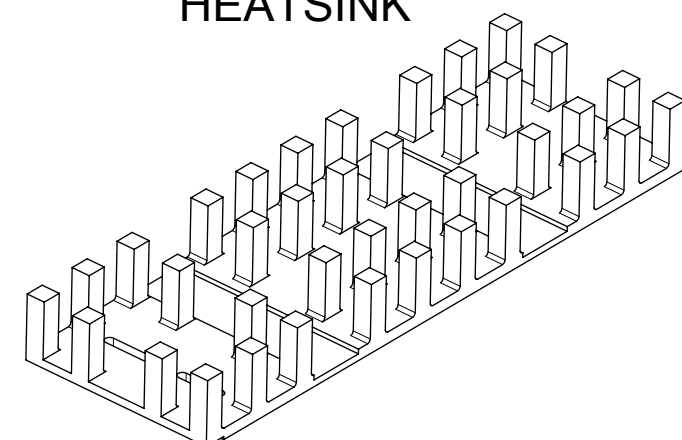

2 ROW QUAD LIGHT PIPE

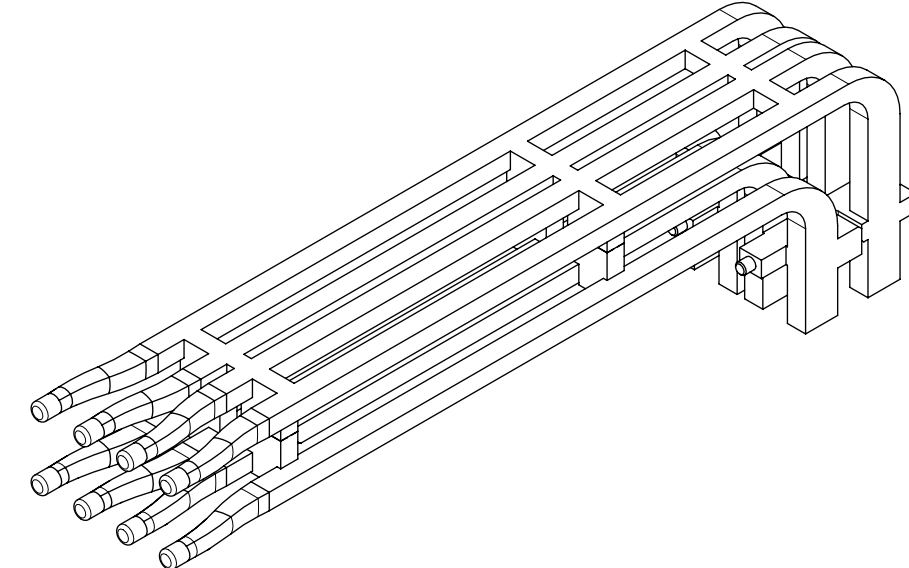

HEATSINK

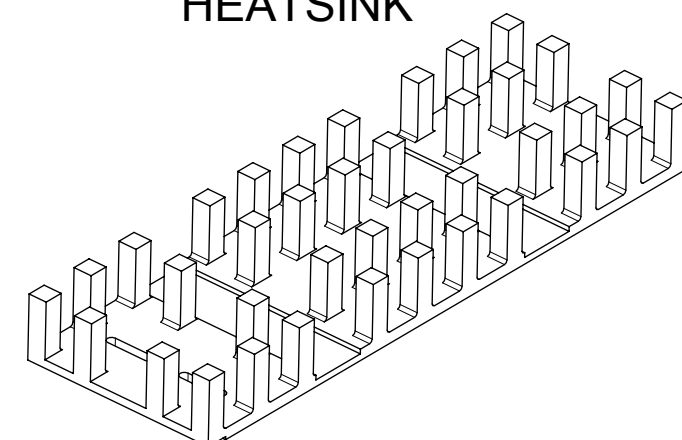

REAR LEG OPTIONS

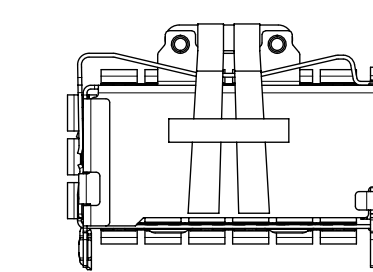

0 REAR LEGS

Partial1
Scale 2.5:1

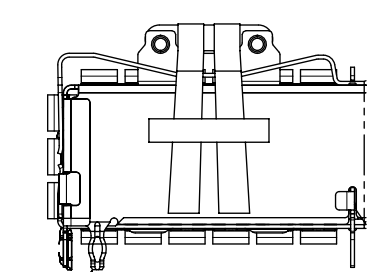

1 REAR LEGS

Partial2
Scale 2.5:1

THIS DRAWING CONTAINS INFORMATION THAT IS PROPRIETARY TO MOLEX ELECTRONIC TECHNOLOGIES, LLC AND SHOULD NOT BE USED WITHOUT WRITTEN PERMISSION

| DIMENSION UNITS | SCALE | CURRENT REV DESC: SEE REVISION TABLE | |
|--|-----------------|--------------------------------------|-----------------|
| mm | 2:1 | | |
| GENERAL TOLERANCES (UNLESS SPECIFIED) | | | |
| ANGULAR TOL | $\pm 1.0^\circ$ | | |
| 4 PLACES | \pm | EC NO: 698865 | |
| 3 PLACES | \pm | DRWN: KRISHH1 | 2022/02/17 |
| 2 PLACES | ± 0.13 | CHK'D: TKUMARKC | 2022/03/10 |
| 1 PLACE | ± 0.25 | APPR: JCHIANG | 2022/03/21 |
| 0 PLACES | \pm | INITIAL REVISION: | |
| DRAFT WHERE APPLICABLE MUST REMAIN WITHIN DIMENSIONS | | DRWN: KRISHH1 | 2022/02/17 |
| THIRD ANGLE PROJECTION | | APPR: JCHIANG | 2022/03/21 |
| DRAWING | | SERIES | MATERIAL NUMBER |
| D-SIZE | | 100017 | SEE P/N TABLE |
| CUSTOMER | | GENERAL MARKET | |
| SHEET NUMBER | | 2 OF 8 | |

molex

ZQSFP+ 1X4 GANGED CAGE ASSY'S
W/ SS TAB TYPE SPRING FINGER H/S & L/P
OPTIONS

PRODUCT CUSTOMER DRAWING

DOCUMENT NUMBER DOC TYPE DOC PART REVISION

1000173200

PSD ASY A

PART NUMBER SELECTION

NO HEATSINKS
NO LIGHT PIPES
CLOSED TOP

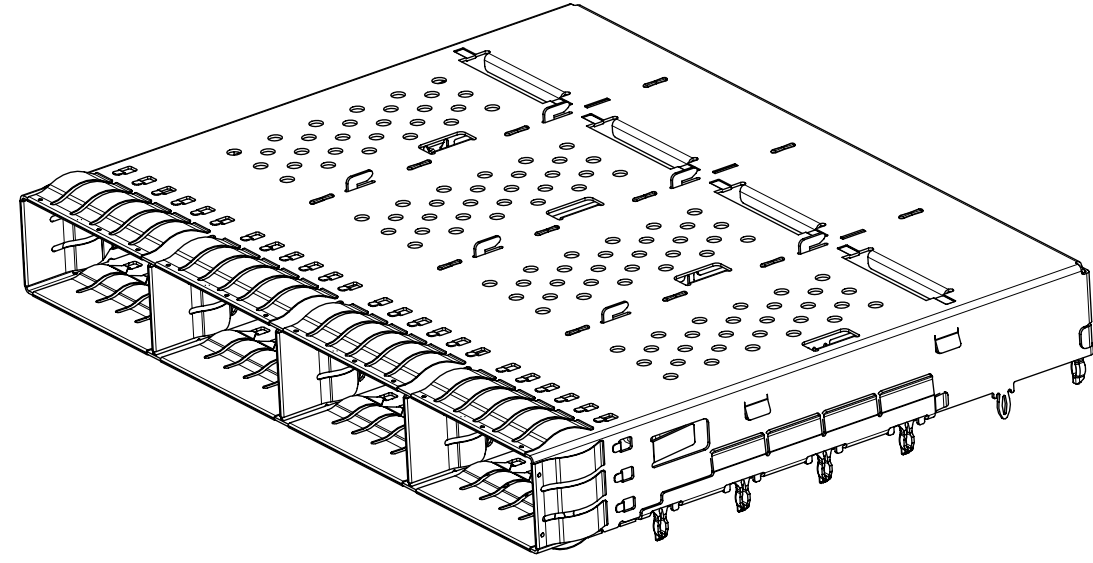

| MOLEX P/N W/ SPRING FINGERS | #OF REAR LEGS PER PORT |
|--------------------------------|---------------------------|
| 1000173242 | 1 |

NO HEATSINKS
NO LIGHT PIPES
OPEN TOP

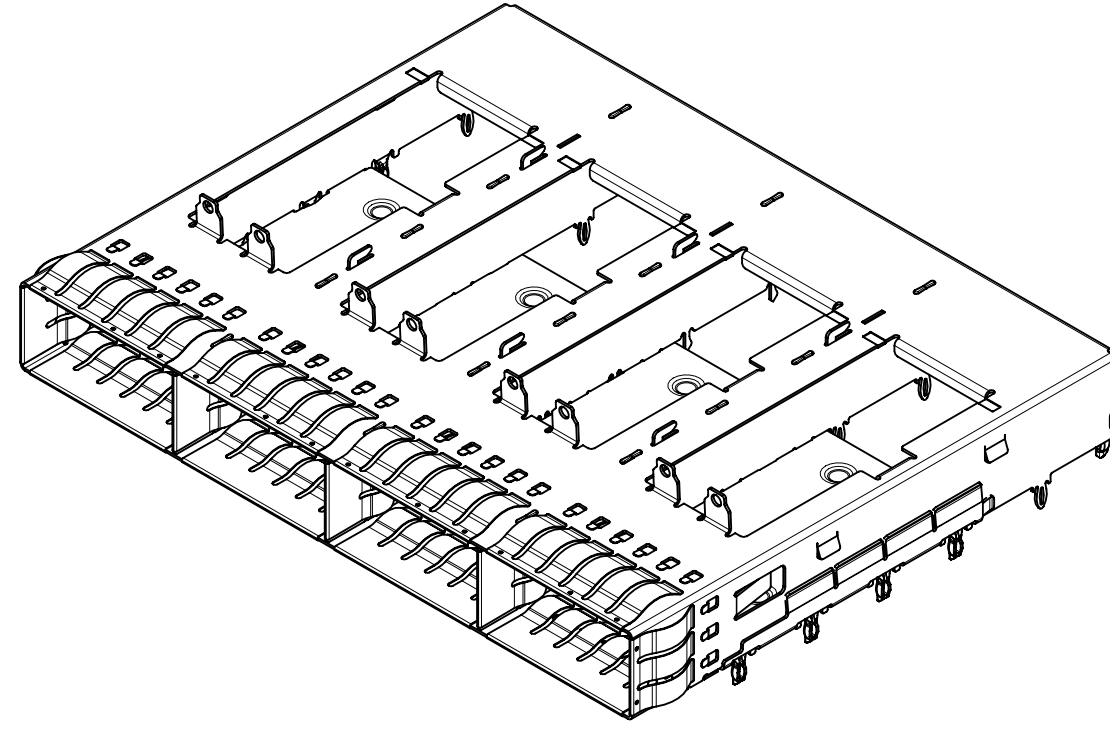

| MOLEX P/N W/ SPRING FINGERS | #OF REAR LEGS PER PORT |
|--------------------------------|---------------------------|
| 1000173252 | 1 |

WITH HEATSINKS
NO LIGHT PIPES

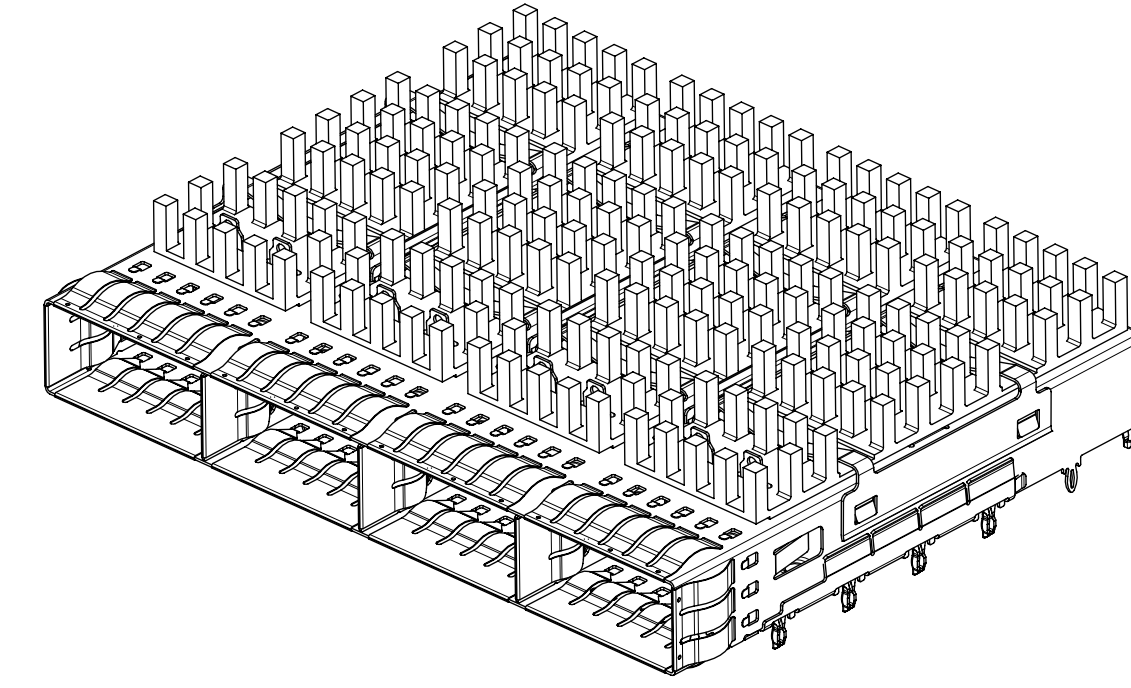

| MOLEX P/N | HEATSINKS | #OF REAR LEGS PER PORT |
|------------|-----------|---------------------------|
| 1000173343 | PCI | 1 |
| 1000173344 | SAN | 1 |

WITH HEATSINKS AND LIGHT PIPES

| MOLEX P/N | LIGHTPIPES | HEATSINKS | #OF REAR LEGS PER PORT |
|------------|------------|-----------|---------------------------|
| 1000173443 | DUAL | PCI | 0 |
| 1000173446 | QUAD | PCI | 0 |
| 1000173542 | SINGLE | NET | 1 |
| 1000173544 | DUAL | SAN | 1 |
| 1000173547 | QUAD | SAN | 1 |
| 1000173548 | QUAD | NET | 1 |

SINGLE LIGHT PIPE

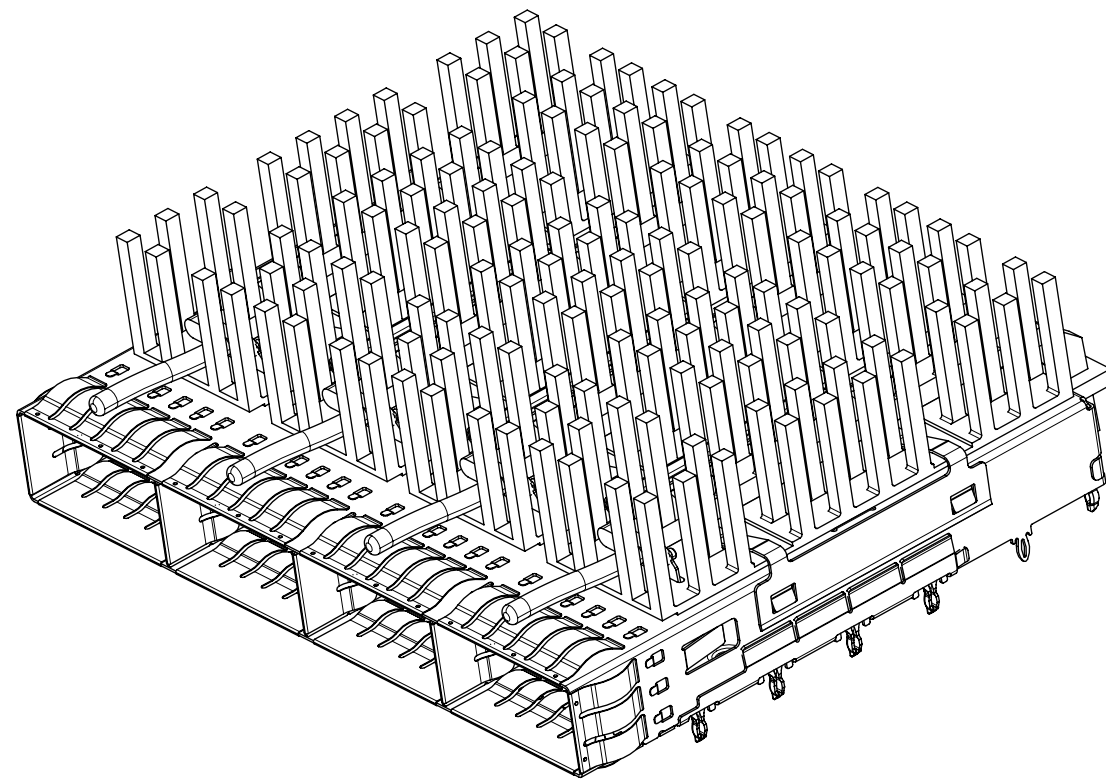

DUAL LIGHT PIPE

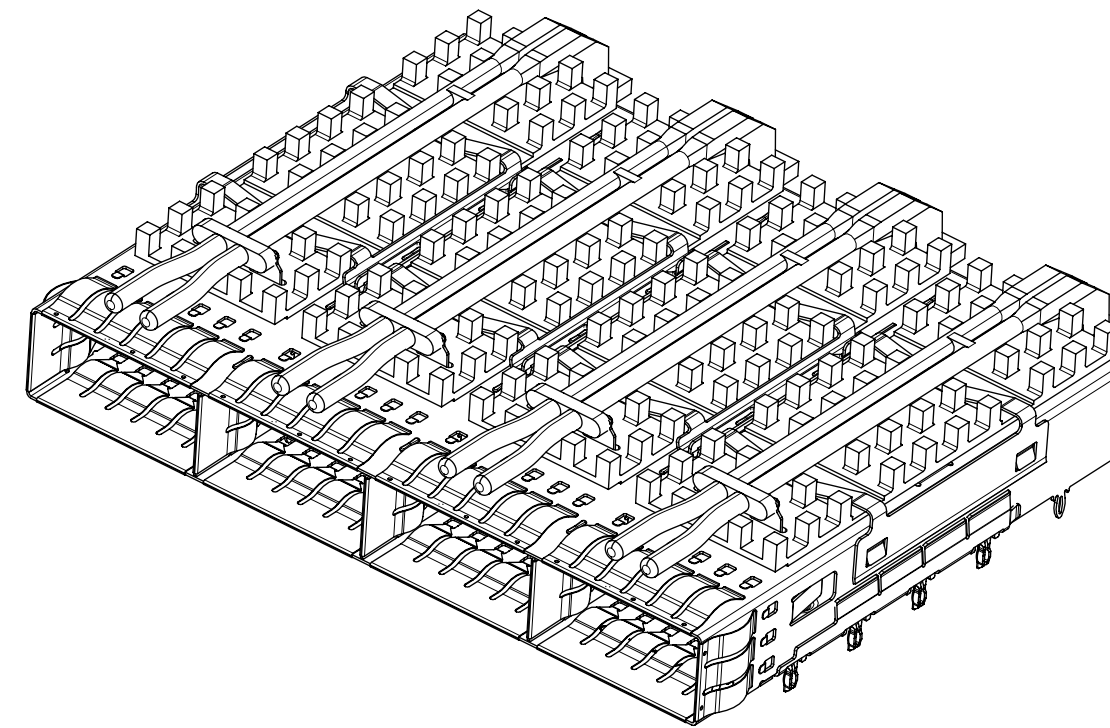

QUAD LIGHT PIPE

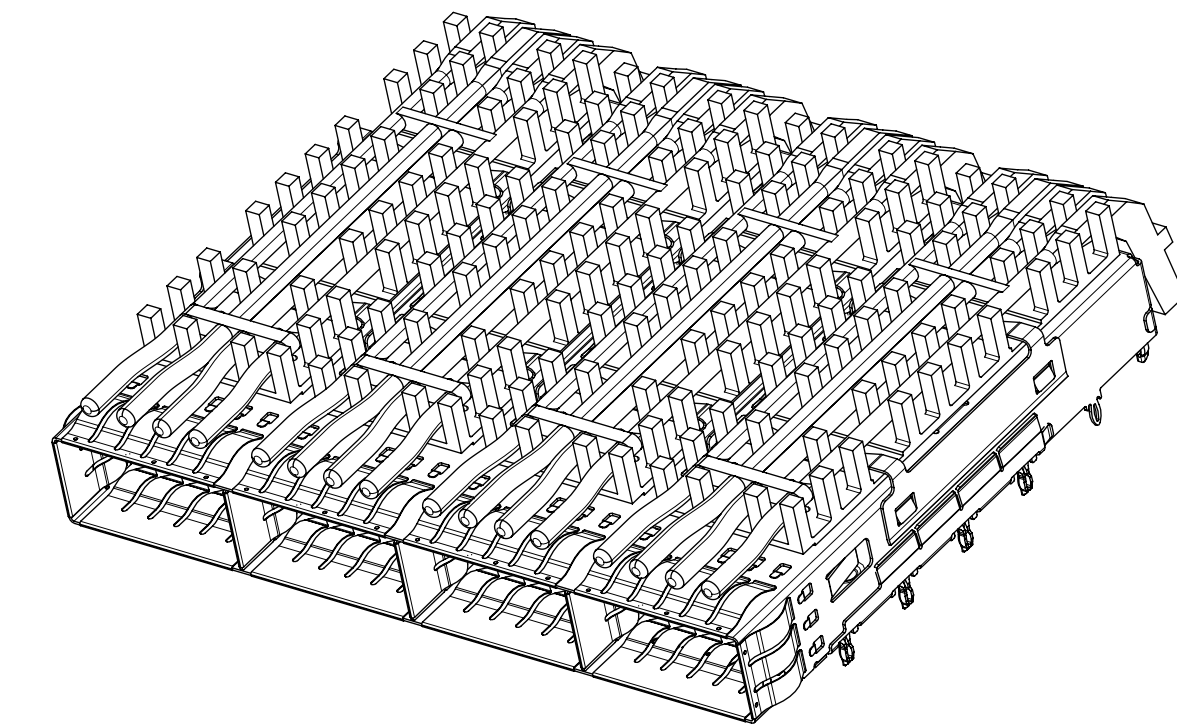

THIS DRAWING CONTAINS INFORMATION THAT IS PROPRIETARY TO MOLEX ELECTRONIC TECHNOLOGIES, LLC AND SHOULD NOT BE USED WITHOUT WRITTEN PERMISSION

| | | | | | |
|--|-----------------------|--|---|-------------------------|--------------------------------------|
| DIMENSION UNITS mm | SCALE 1.5:1 | CURRENT REV DESC: SEE REVISION TABLE | | | |
| GENERAL TOLERANCES (UNLESS SPECIFIED) | | | | | |
| ANGULAR TOL ± 1.0° | 4 PLACES ± | EC NO: 698865 | ZQSFP+ 1X4 GANGED CAGE ASSYS W/ SS TAB TYPE SPRING FINGER H/S & L/P OPTIONS | | |
| 3 PLACES ± | 2 PLACES ± 0.13 | DRWN: KRISHH1 2022/02/17 CHK'D: TKUMARKC 2022/03/10 APPR: JCHIANG 2022/03/21 | | | |
| 1 PLACE ± 0.25 | 0 PLACES ± | INITIAL REVISION: DRWN: KRISHH1 2022/02/17 APPR: JCHIANG 2022/03/21 | PRODUCT CUSTOMER DRAWING | | |
| DRAFT WHERE APPLICABLE MUST REMAIN WITHIN DIMENSIONS | | THIRD ANGLE PROJECTION | DRAWING D-SIZE | SERIES 100017 | DOCUMENT NUMBER 1000173200 |
| | | | | | DOC TYPE PSD |
| | | | | | DOC PART ASY |
| | | | | | REVISION A |
| | | | | | MATERIAL NUMBER SEE P/N TABLE |
| | | | | | CUSTOMER GENERAL MARKET |
| | | | | | SHEET NUMBER 3 OF 8 |

PCB LAYOUT FOR SINGLE SIDED MOUNTING

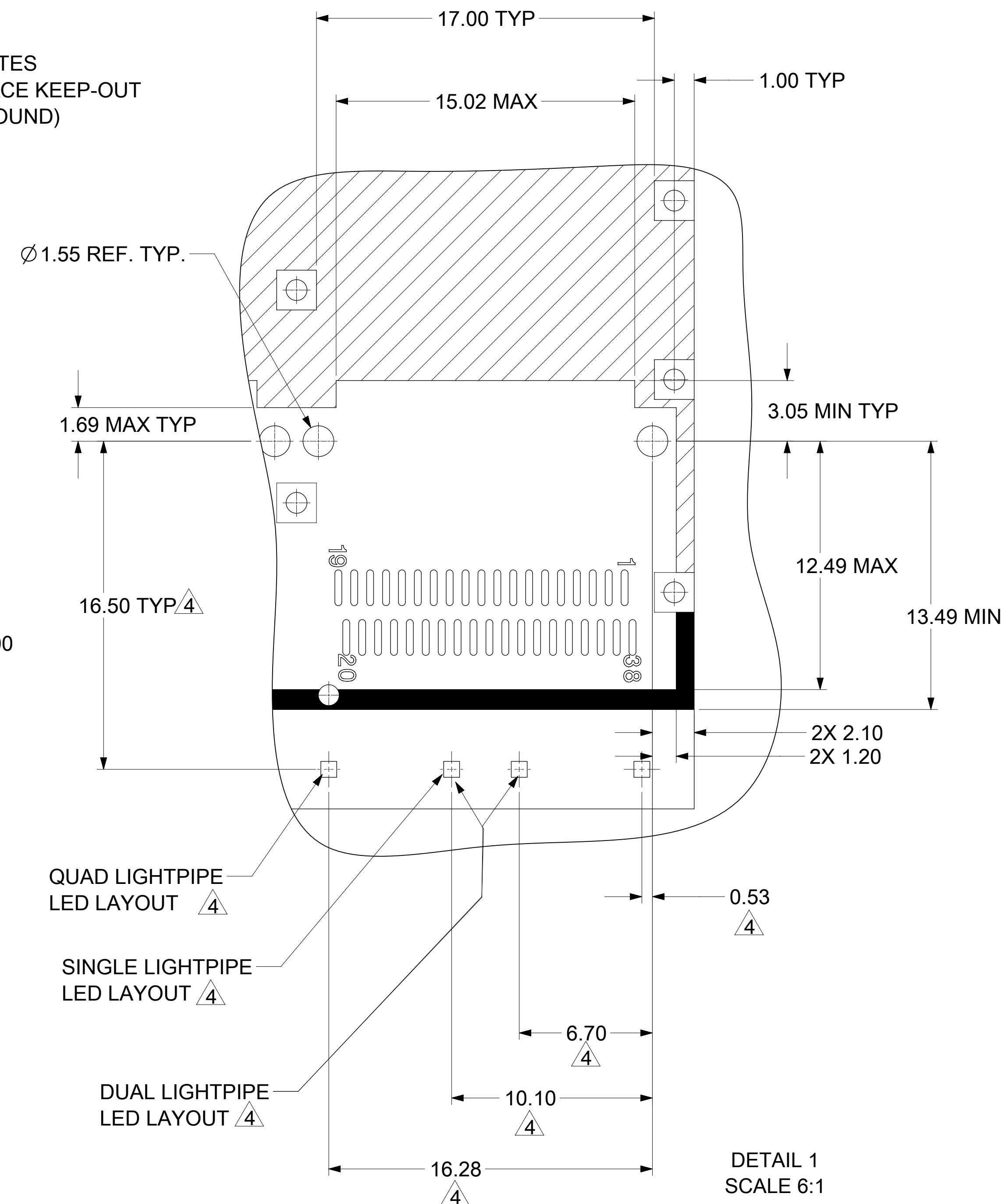
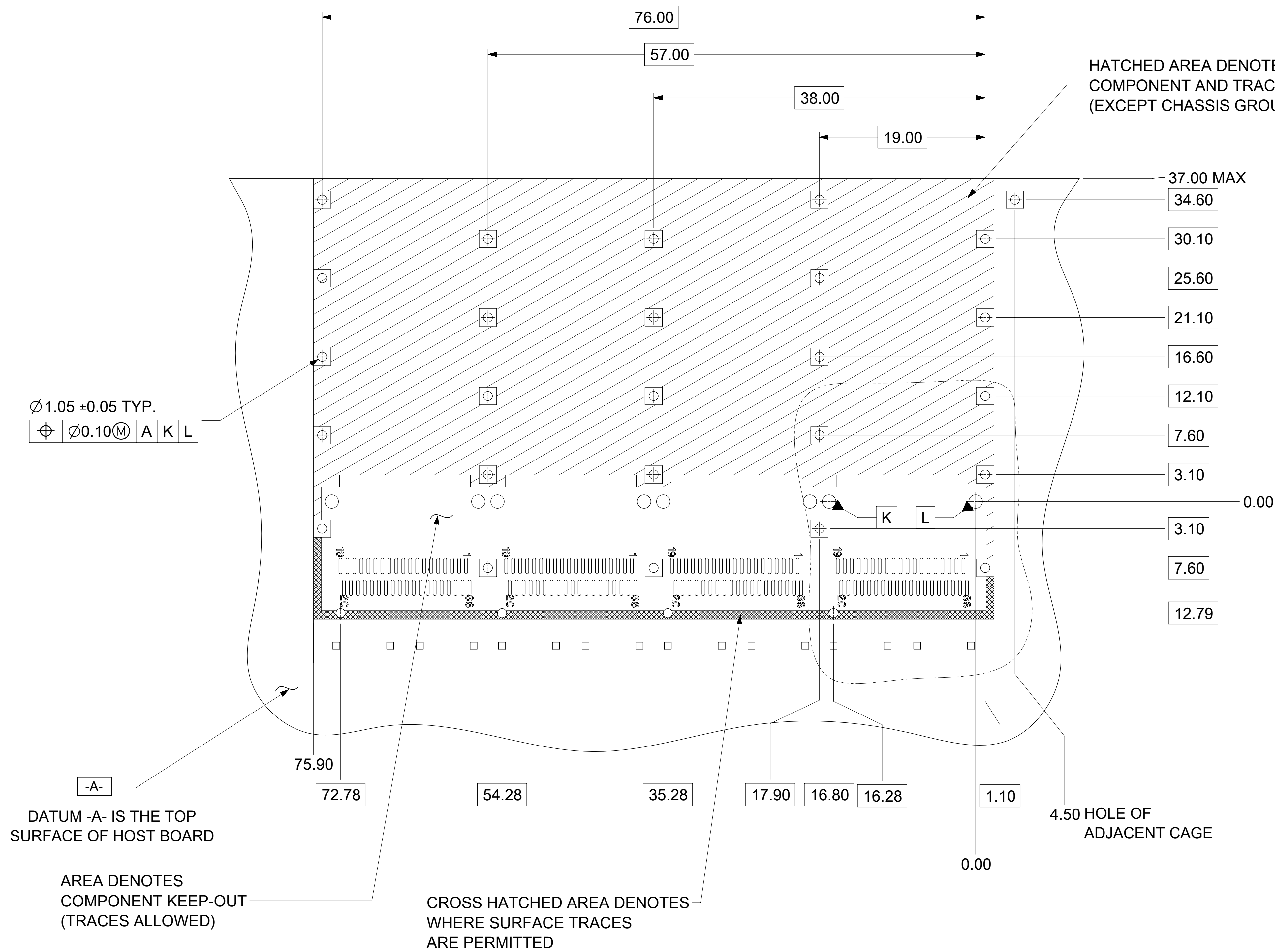

- NOTES:
1. PADS AND VIAS GO TO CHASSIS GROUND. (RECOMMENDED PADS TO BE 2.00mm SQUARE.)
 2. RECOMMENDED THRU HOLE PLATING INCLUDES HASL, OSP, OR IMMERSION (GOLD, SILVER, OR TIN).
 3. CONNECTOR PAD LAYOUT PER SFF-8663 WILL ACCOMODATE MOLEX CONNECTOR SERIES 170432.
 4. NOTED DIMENSIONS ONLY APPLY TO CAGE ASSEMBLIES WITH LIGHT PIPES.

| | | | | | | | | | |
|---|--|-------------------|--|--------------------------------------|--|----------------|--|--------------|--|
| THIS DRAWING CONTAINS INFORMATION THAT IS PROPRIETARY TO MOLEX ELECTRONIC TECHNOLOGIES, LLC AND SHOULD NOT BE USED WITHOUT WRITTEN PERMISSION | | | | | | | | | |
| DIMENSION UNITS | | SCALE | | CURRENT REV DESC: SEE REVISION TABLE | | | | | |
| mm | | 3.5:1 | | | | | | | |
| GENERAL TOLERANCES (UNLESS SPECIFIED) | | | | | | | | | |
| ANGULAR TOL ± 1.0° | | | | | | | | | |
| 4 PLACES ± | | EC NO: 698865 | | DRWN: KRISHH1 | | 2022/02/17 | | | |
| 3 PLACES ± | | CHK'D: TKUMARKC | | 2022/03/10 | | | | | |
| 2 PLACES ± 0.13 | | APPR: JCHIANG | | 2022/03/21 | | | | | |
| 1 PLACE ± 0.25 | | INITIAL REVISION: | | DRWN: KRISHH1 | | 2022/02/17 | | | |
| 0 PLACES ± | | APPR: JCHIANG | | 2022/03/21 | | | | | |
| DRAFT WHERE APPLICABLE MUST REMAIN WITHIN DIMENSIONS | | | | THIRD ANGLE PROJECTION | | DRAWING | | SERIES | |
| | | | | D-SIZE | | 100017 | | | |
| | | | | MATERIAL NUMBER | | CUSTOMER | | SHEET NUMBER | |
| | | | | SEE P/N TABLE | | GENERAL MARKET | | 4 OF 8 | |

molex

ZQSFP+ 1X4 GANGED CAGE ASSY'S
W/ SS TAB TYPE SPRING FINGER H/S & L/P
OPTIONS

PRODUCT CUSTOMER DRAWING

| | | | |
|-----------------|----------|----------|----------|
| DOCUMENT NUMBER | DOC TYPE | DOC PART | REVISION |
| 1000173200 | PSD | ASY | A |

PCB LAYOUT FOR BELLY TO BELLY MOUNTING

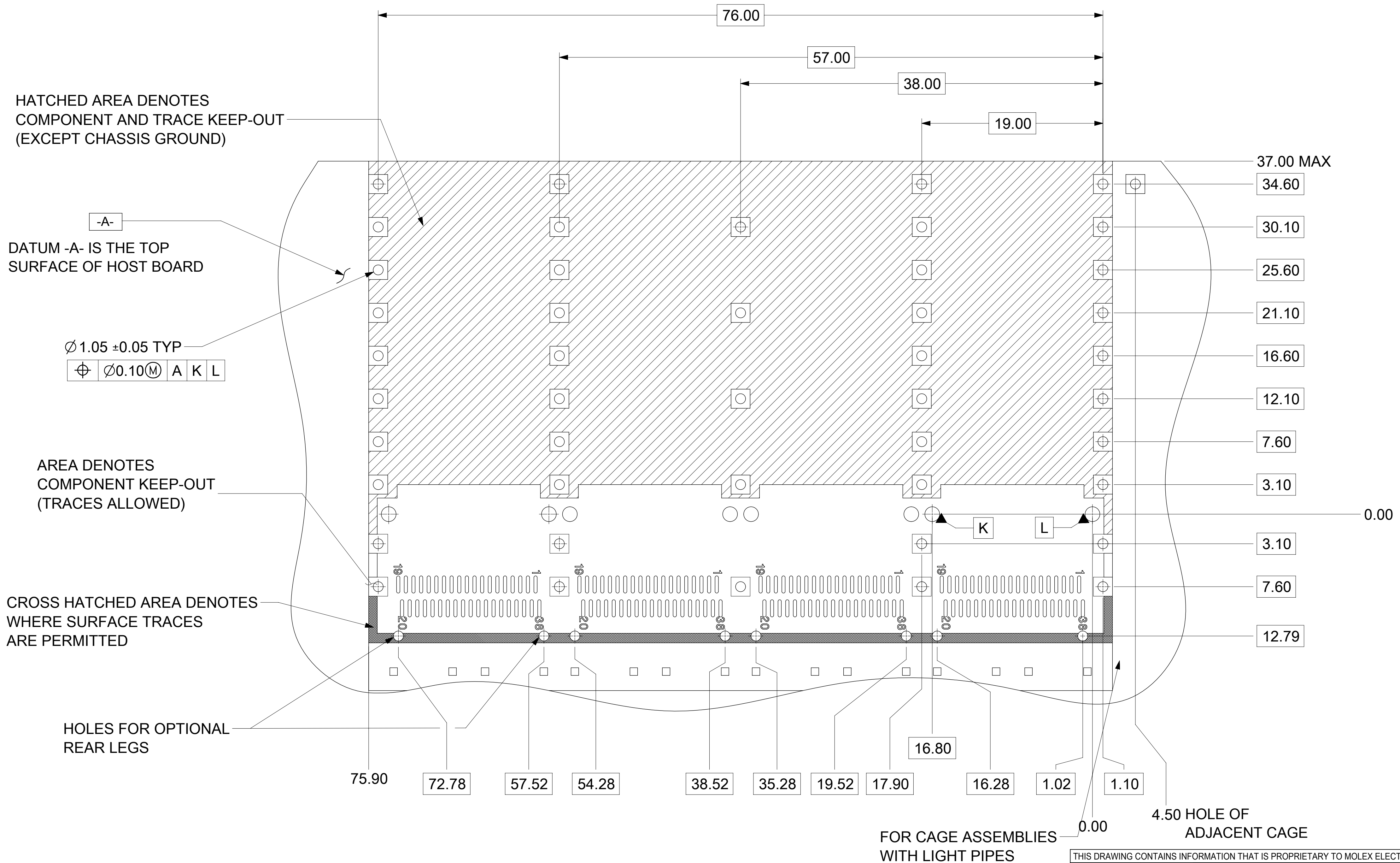

HATCHED AREA DENOTES COMPONENT AND TRACE KEEP-OUT (EXCEPT CHASSIS GROUND)

-A- DATUM -A- IS THE TOP SURFACE OF HOST BOARD

Ø1.05 ±0.05 TYP
 Ø0.10 (M) A K L

AREA DENOTES COMPONENT KEEP-OUT (TRACES ALLOWED)

CROSS HATCHED AREA DENOTES WHERE SURFACE TRACES ARE PERMITTED

HOLES FOR OPTIONAL REAR LEGS

NOTE:
 SEE SHEET 4 FOR HOST CONNECTOR DETAIL AND SINGLE ROW LED LOCATION DETAIL

SEE SHEET 6 FOR DUAL-QUAD LED LOCATION DETAIL

- NOTES:
1. PADS AND VIAS GO TO CHASSIS GROUND. (RECOMMENDED PADS TO BE 2.00mm SQUARE.)
 2. RECOMMENDED THRU HOLE PLATING INCLUDES HASL, OSP, OR IMMERSION (GOLD, SILVER, OR TIN).
 3. CONNECTOR PAD LAYOUT PER SFF-8663 WILL ACCOMODATE MOLEX CONNECTOR SERRIES 170432.

FOR CAGE ASSEMBLIES WITH LIGHT PIPES

4.50 HOLE OF ADJACENT CAGE

THIS DRAWING CONTAINS INFORMATION THAT IS PROPRIETARY TO MOLEX ELECTRONIC TECHNOLOGIES, LLC AND SHOULD NOT BE USED WITHOUT WRITTEN PERMISSION

| | | | | | | | |
|--|---------------------|--------------------------------------|------------|--------------------------|----------|--------------|--|
| DIMENSION UNITS mm | SCALE 4:1 | CURRENT REV DESC: SEE REVISION TABLE | | | | | |
| GENERAL TOLERANCES (UNLESS SPECIFIED) | | EC NO: 698865 | | | | | |
| ANGULAR TOL ± 1.0° | 4 PLACES ± | DRWN: KRISHH1 | 2022/02/17 | PRODUCT CUSTOMER DRAWING | | | |
| 3 PLACES ± | 3 PLACES ± | CHK'D: TKUMARKC | 2022/03/10 | DOCUMENT NUMBER | | | |
| 2 PLACES ± 0.13 | 2 PLACES ± | APPR: JCHIANG | 2022/03/21 | 1000173200 | | | |
| 1 PLACE ± 0.25 | 1 PLACE ± | INITIAL REVISION: | | DOC TYPE | DOC PART | REVISION | |
| 0 PLACES ± | 0 PLACES ± | DRWN: KRISHH1 | 2022/02/17 | PSD | ASY | A | |
| DRAFT WHERE APPLICABLE MUST REMAIN WITHIN DIMENSIONS | | APPR: JCHIANG | 2022/03/21 | MATERIAL NUMBER | | CUSTOMER | |
| THIRD ANGLE PROJECTION | | DRAWING | | SERIES | | SHEET NUMBER | |
| | | D-SIZE | | 100017 | | 5 OF 8 | |
| | | SEE P/N TABLE | | GENERAL MARKET | | | |

| | | | |
|-----------------|----|--------------|---------------------|
| DOCUMENT STATUS | P1 | RELEASE DATE | 2022/03/21 02:37:39 |
|-----------------|----|--------------|---------------------|

BEZEL AND BOARD POSITION DIMENSIONS
FOR BELLY TO BELLY MOUNTING

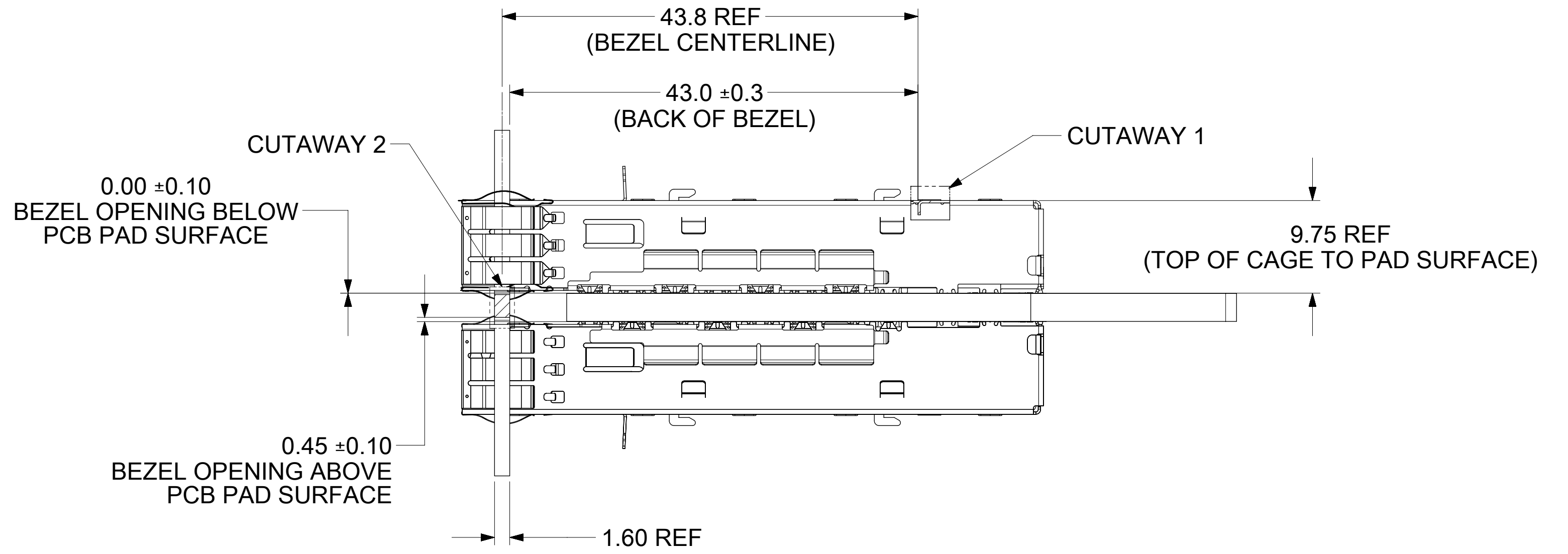
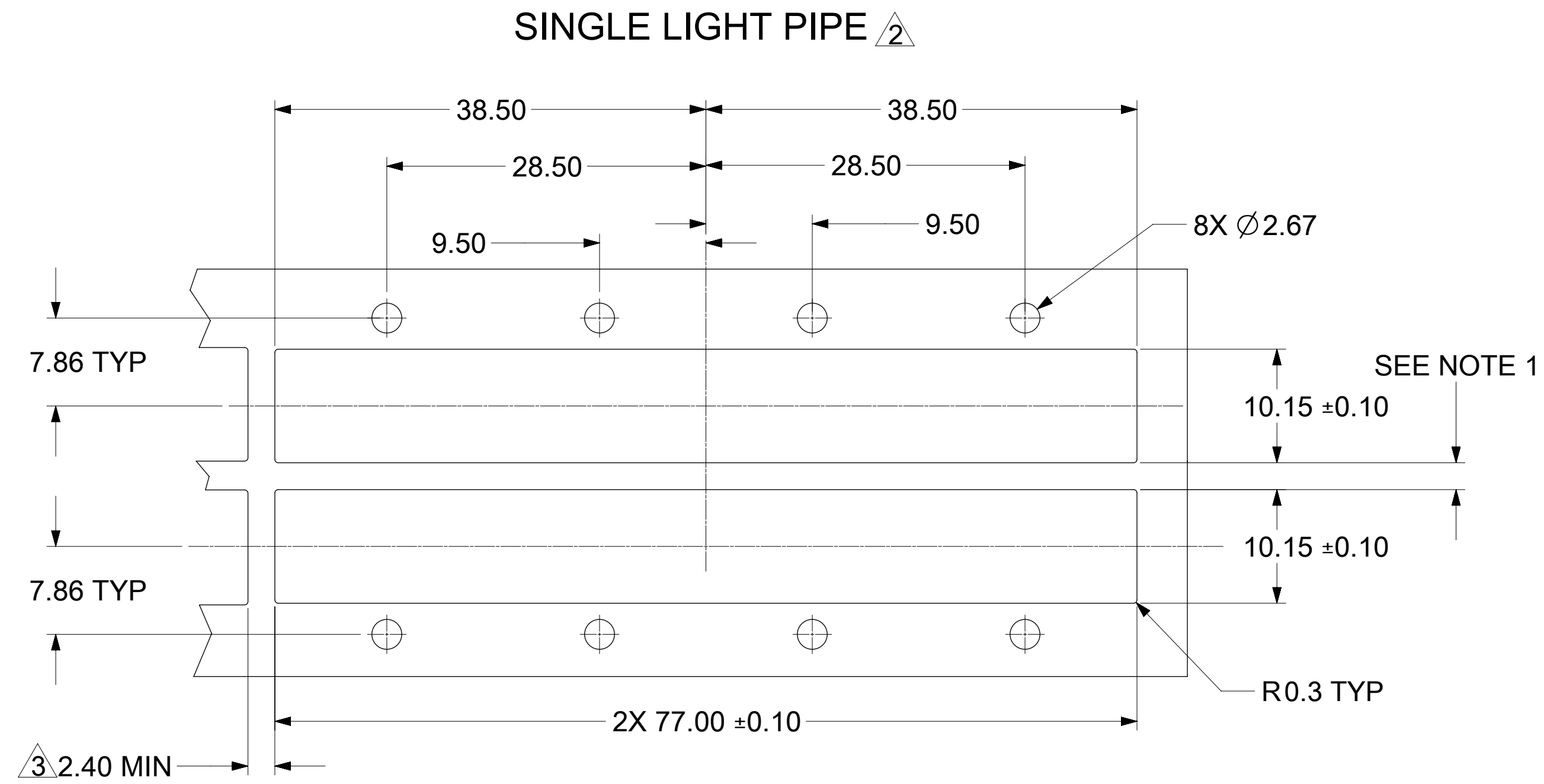

DUAL LIGHT PIPE AND QUAD LIGHT PIPE

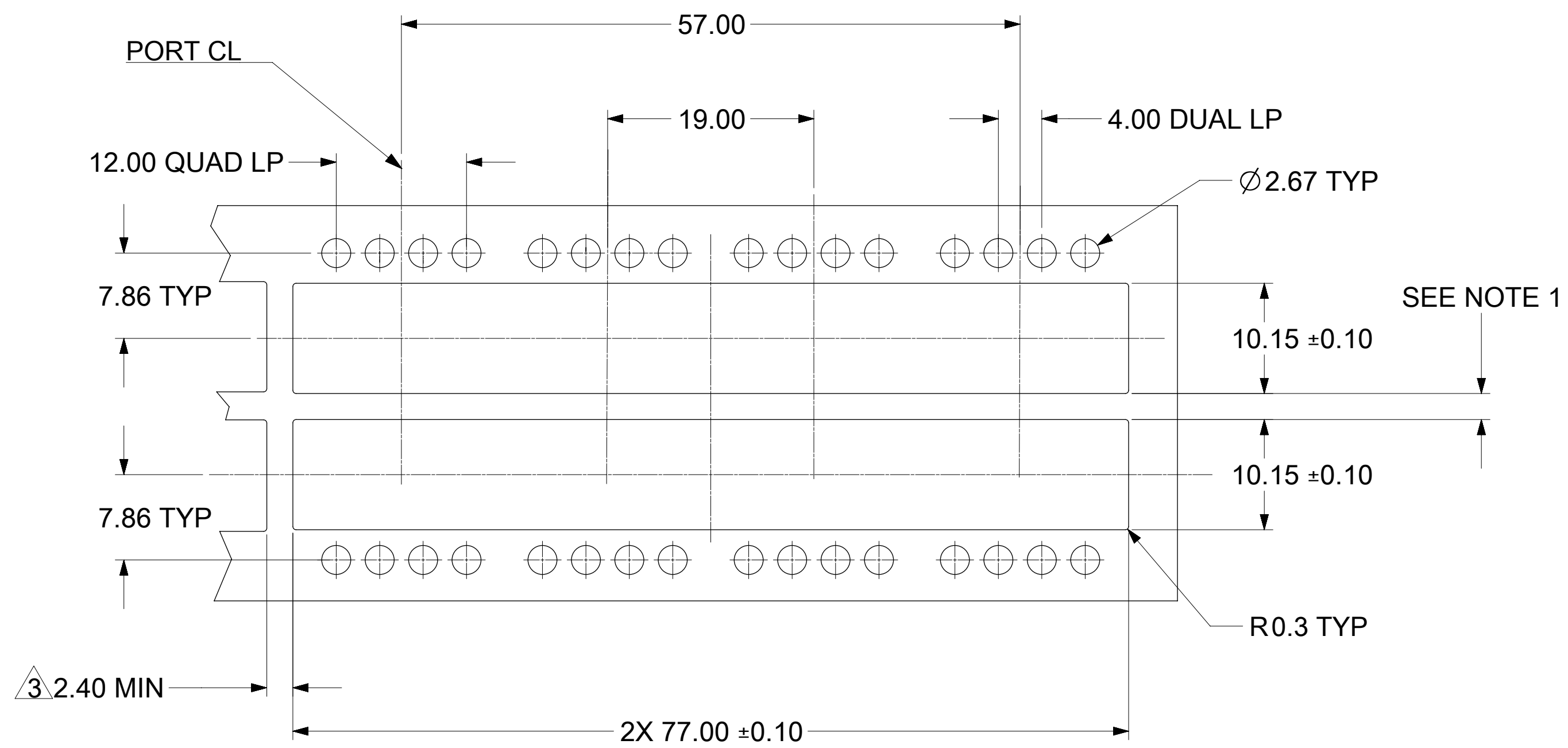

- NOTE:
1. PCB THICKNESS VARIATION MUST BE CONSIDERED WHEN DETERMINING BEZEL OPENING LOCATION.
 2. NOTED DIMENSIONS ONLY APPLY TO CAGE ASSEMBLIES WITH LIGHT PIPES.
 3. THIS DIMENSION IS FOR REFERENCE ONLY. USER CAN MODIFY IT DEPENDS ON APPLICATION. (THIS DIMENSION VARIES BASED ON DISTANCE OF " HOLE OF ADJACENT CAGE" ON PCB LAYOUT.)

| | | | | | | | | | |
|---|--------|--|---------------|------------|-----------------|----------------|--------------|--|--|
| THIS DRAWING CONTAINS INFORMATION THAT IS PROPRIETARY TO MOLEX ELECTRONIC TECHNOLOGIES, LLC AND SHOULD NOT BE USED WITHOUT WRITTEN PERMISSION | | | | | | | | | |
| DIMENSION UNITS | SCALE | CURRENT REV DESC: SEE REVISION TABLE | | | | | | | |
| mm | 2.5:1 | <p>molex</p> <p>ZQSFP+ 1X4 GANGED CAGE ASSYS W/ SS TAB TYPE SPRING FINGER H/S & L/P OPTIONS</p> <p>PRODUCT CUSTOMER DRAWING</p> <p>DOCUMENT NUMBER: 1000173200 DOC TYPE: PSD DOC PART: ASY REVISION: A</p> <p>DRAFT WHERE APPLICABLE MUST REMAIN WITHIN DIMENSIONS</p> | | | | | | | |
| GENERAL TOLERANCES (UNLESS SPECIFIED) | | | | | | | | | |
| ANGULAR TOL | ± 1.0° | | | | | | | | |
| 4 PLACES | ± | | | | | | | | |
| 3 PLACES | ± | | | | | | | | |
| 2 PLACES | ± 0.13 | | | | | | | | |
| 1 PLACE | ± 0.25 | EC NO: 698865 | DRWN: KRISHH1 | 2022/02/17 | | | | | |
| 0 PLACES | ± | CHK'D: TKUMARKC | 2022/03/10 | | | | | | |
| | | APPR: JCHIANG | 2022/03/21 | | | | | | |
| | | INITIAL REVISION: | | | | | | | |
| | | DRWN: KRISHH1 | 2022/02/17 | | | | | | |
| | | APPR: JCHIANG | 2022/03/21 | | | | | | |
| | | THIRD ANGLE PROJECTION | DRAWING | SERIES | MATERIAL NUMBER | CUSTOMER | SHEET NUMBER | | |
| | | | D-SIZE | 100017 | SEE P/N TABLE | GENERAL MARKET | 6 OF 8 | | |

BEZEL AND BOARD POSITION DIMENSIONS
FOR SINGLE SIDE MOUNTING

SINGLE LIGHT PIPE ²

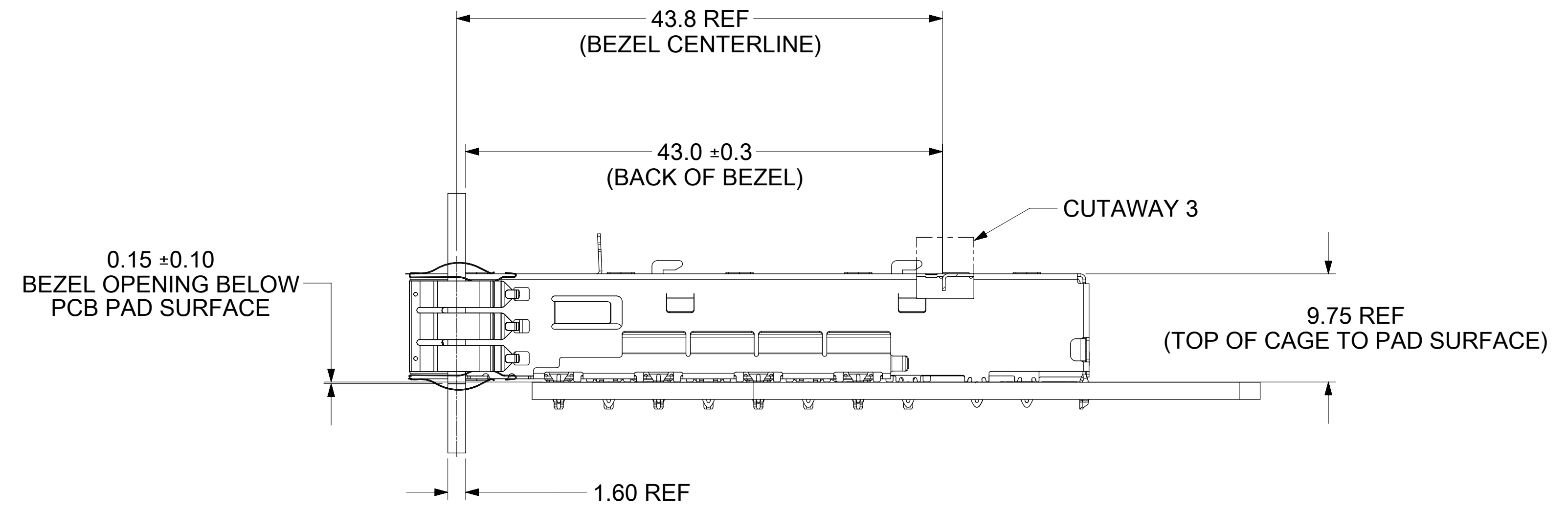
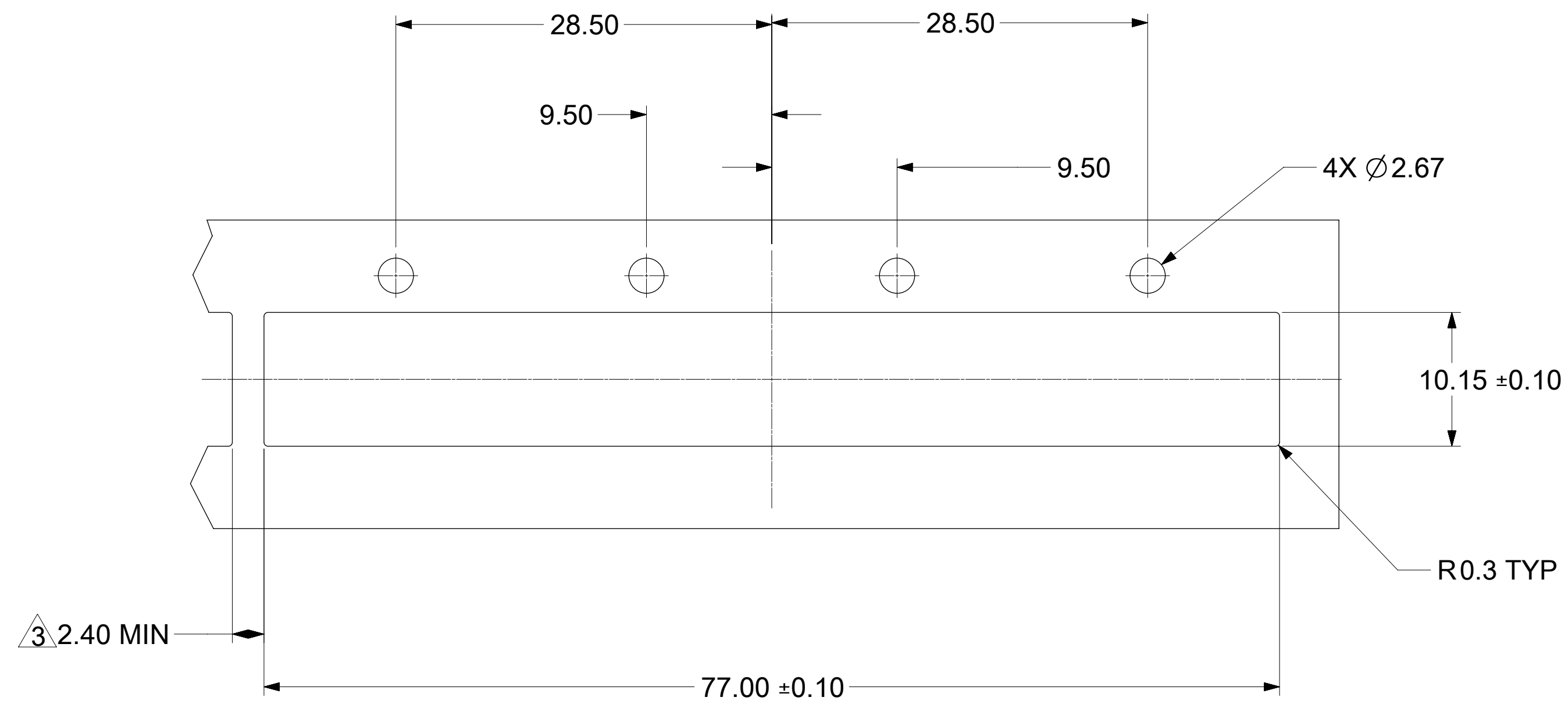

DUAL LIGHT PIPE AND QUAD LIGHT PIPE ²

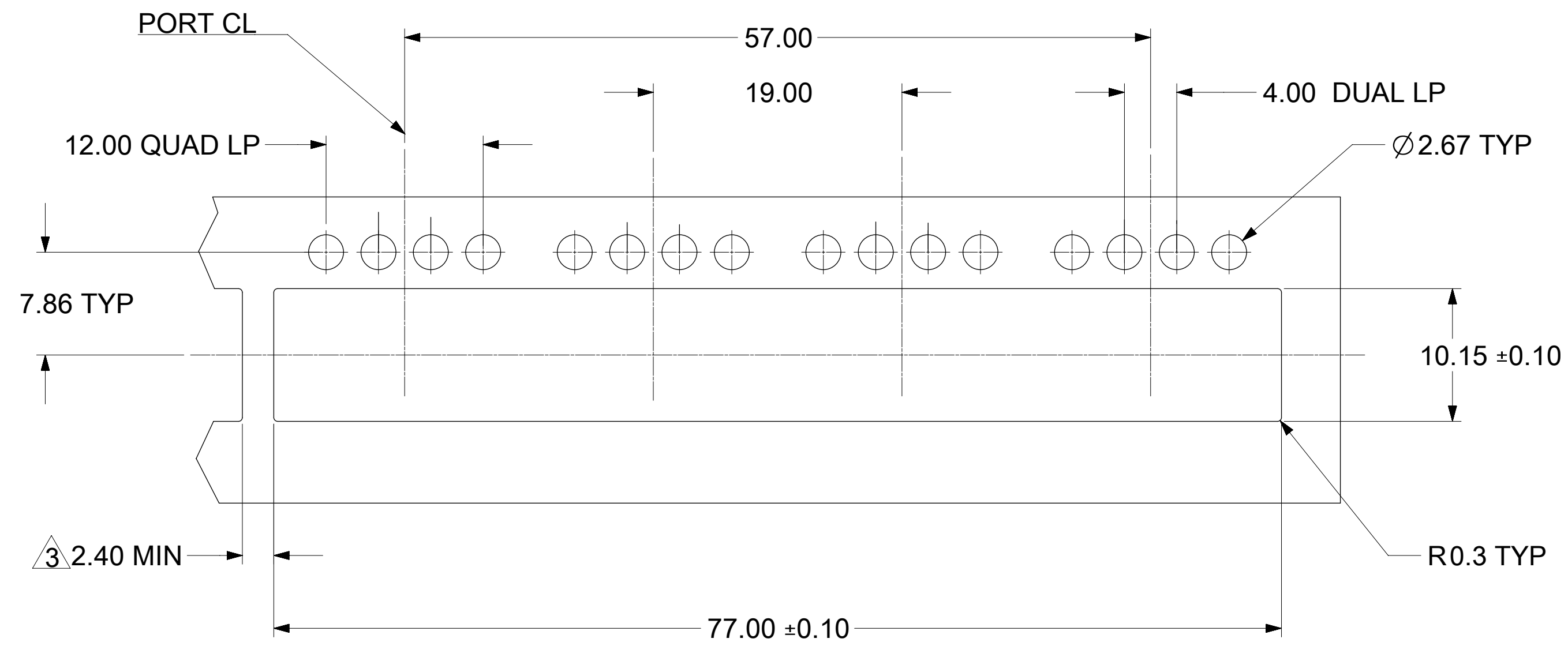

| | | | | | | | | | |
|---|--------|---|---------------|------------|--|--|--|--|--|
| THIS DRAWING CONTAINS INFORMATION THAT IS PROPRIETARY TO MOLEX ELECTRONIC TECHNOLOGIES, LLC AND SHOULD NOT BE USED WITHOUT WRITTEN PERMISSION | | | | | | | | | |
| DIMENSION UNITS | SCALE | CURRENT REV DESC: SEE REVISION TABLE | | | | | | | |
| mm | 3:1 | <p>molex</p> <p>ZQSFP+ 1X4 GANGED CAGE ASSY'S W/ SS TAB TYPE SPRING FINGER H/S & L/P OPTIONS</p> <p>PRODUCT CUSTOMER DRAWING</p> <p>DOCUMENT NUMBER: 1000173200 DOC TYPE: PSD DOC PART: ASY REVISION: A</p> <p>MATERIAL NUMBER: SEE P/N TABLE CUSTOMER: GENERAL MARKET SHEET NUMBER: 7 OF 8</p> | | | | | | | |
| GENERAL TOLERANCES (UNLESS SPECIFIED) | | | | | | | | | |
| ANGULAR TOL | ± 1.0° | | | | | | | | |
| 4 PLACES | ± | | | | | | | | |
| 3 PLACES | ± | | | | | | | | |
| 2 PLACES | ± 0.13 | | | | | | | | |
| 1 PLACE | ± 0.25 | EC NO: 698865 | DRWN: KRISHH1 | 2022/02/17 | | | | | |
| 0 PLACES | ± | CHK'D: TKUMARKC | 2022/03/10 | | | | | | |
| DRAFT WHERE APPLICABLE MUST REMAIN WITHIN DIMENSIONS | | THIRD ANGLE PROJECTION | DRAWING | SERIES | | | | | |
| | | | D-SIZE | 100017 | | | | | |

NOTE:
1. PCB THICKNESS VARIATION MUST BE CONSIDERED WHEN DETERMINING BEZEL OPENING LOCATION.
² NOTED DIMENSIONS ONLY APPLY TO CAGE ASSEMBLIES WITH LIGHT PIPES.
³ THIS DIMENSION IS FOR REFERENCE ONLY. USER CAN MODIFY IT DEPENDS ON APPLICATION. (THIS DIMENSION VARIES BASED ON DISTANCE OF " HOLE OF ADIACENT CAGE" ON PCB LAYOUT.)

| | | | |
|-----------------|----|--------------|---------------------|
| DOCUMENT STATUS | P1 | RELEASE DATE | 2022/03/21 02:37:39 |
|-----------------|----|--------------|---------------------|

