

May.1.2023 Copyright 2023 HIROSE ELECTRIC CO., LTD. All Rights Reserved.
In case of consideration for using Automotive equipment / device which demand high reliability, kindly contact our sales window correspondents.

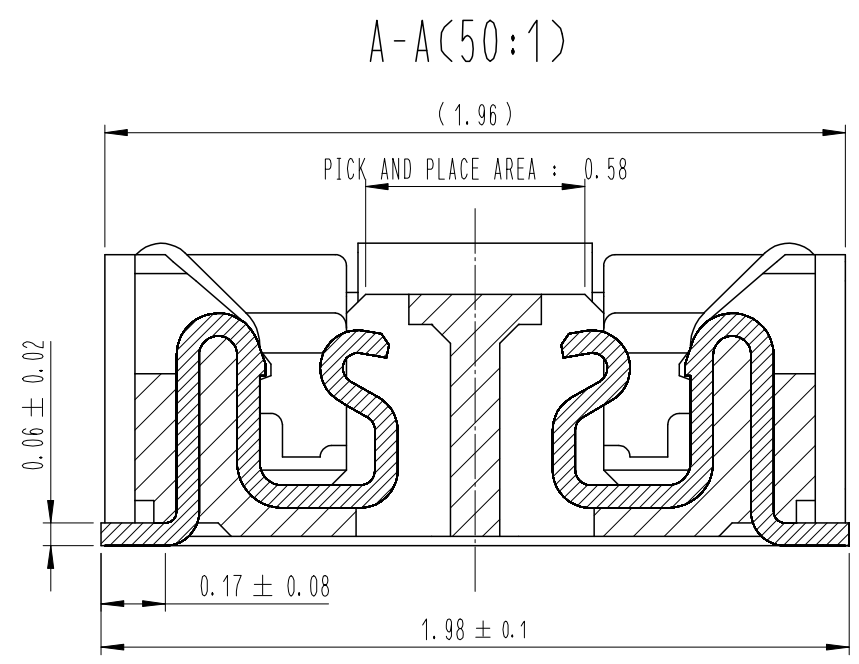

ENGAGEMENT FIGURE (50:1)

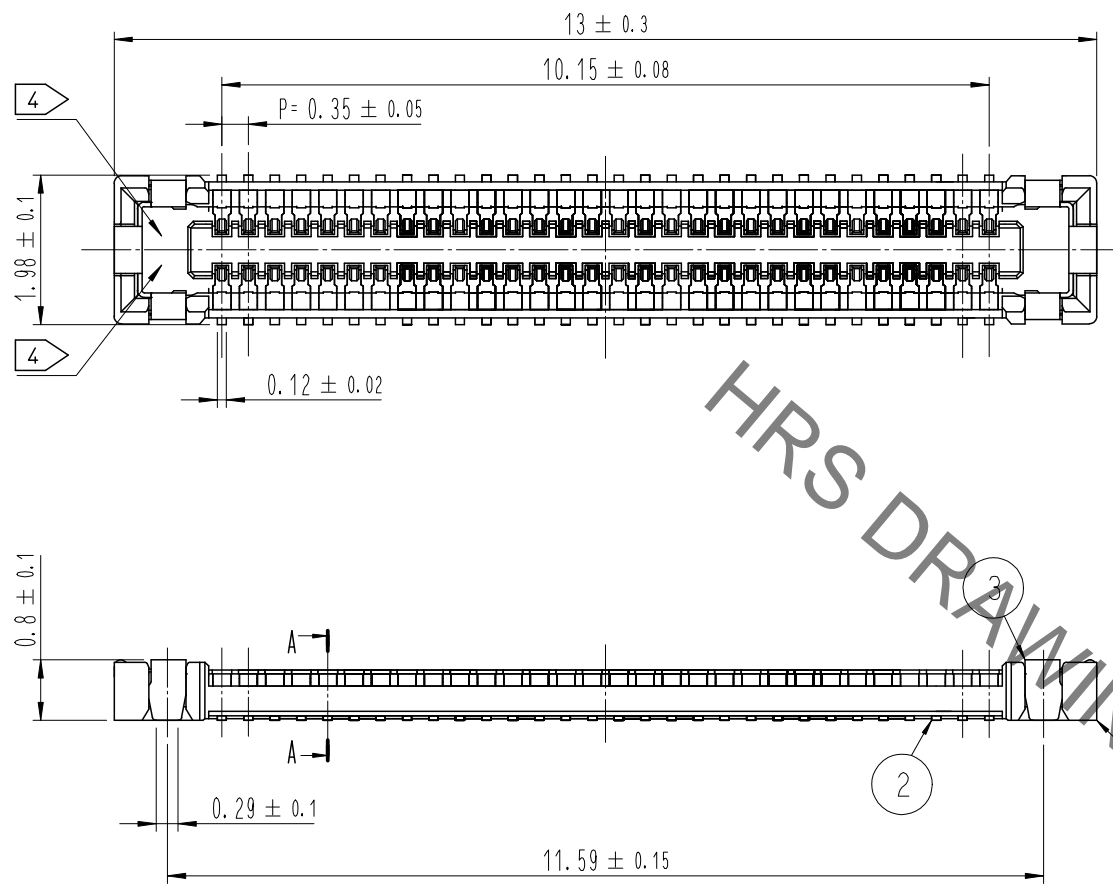
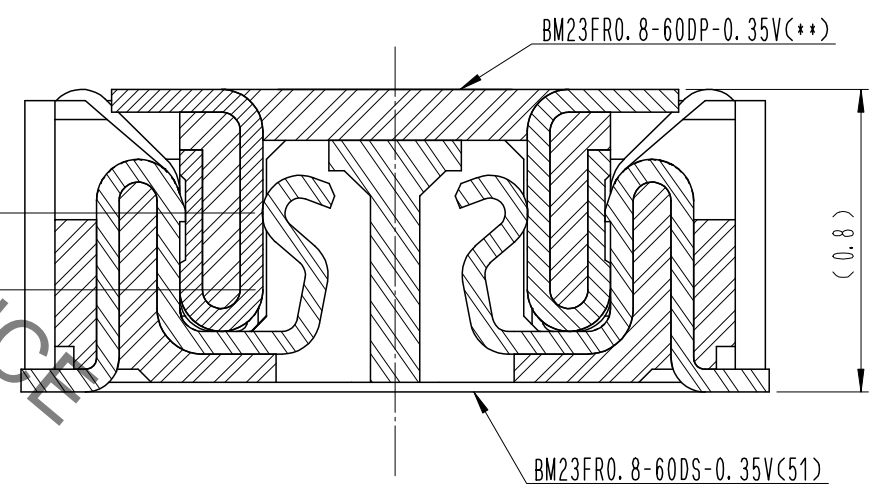

- NOTE
- 1 . ALL LEAD CO-PLANARITY SHALL BE 0.08mm MAX.
 - 2 . CONTACT PLATING SPECIFICATIONS.
CONTACT AREA : GOLD 0.05 μm MIN.
SMT LEAD : GOLD 0.05 μm MIN.
UNDERPLATING : NICKEL 1 μm MIN.
(SURFACE : SEALING)
 - 3 . METAL FITTING PLATING SPECIFICATIONS.
SMT LEAD : GOLD 0.05 μm MIN.
UNDERPLATING : NICKEL 1 μm MIN.
(SURFACE : SEALING)
 - 4 . HRS MARK AND CAV NO. IS INDICATED IN APPROX POSITION SHOWN.

COUNT	DESCRIPTION OF REVISIONS	B	Y	CHKD	DATE	COUNT	DESCRIPTION OF REVISIONS	B	Y	CHKD	DATE
1	Change the bobbin size	LYJ	JHW		15. 12. 03						

4	PS	CLEAR (EMBOSSED CARRIER TAPE)									
3	PHOSPHOR BRONZE	3									
2	PHOSPHOR BRONZE	2				6	PS				BLACK (PLASTIC REEL)
1	LCP	UL94 V-0, BLACK				5	POLYESTER				CLEAR (COVER TAPE)
NO.	MATERIAL	FINISH , REMARKS	NO.	MATERIAL	FINISH , REMARKS						
REMARKS						DRAWN	DESIGNED	CHECKED	APPROVED	RELEASED	
						Y. J. LEE	Y. J. LEE	H. W. JO	T. S. KANG	15. 12. 03	
						15. 12. 03	15. 12. 03	15. 12. 03	15. 12. 03		
CODE NO. (OLD)	DRAWING NO. EDC3-632085		PART NO. BM23FR0.8-60DS-0.35V(51)								
SCALE 10:1	UNITS mm		HRS HIROSE KOREA CO., LTD.			CODE NO	CL 6644-0028-3-051			1/3	

May.1.2023 Copyright 2023 HIROSE ELECTRIC CO., LTD. All Rights Reserved.
In case of consideration for using Automotive equipment / device which demand high reliability, kindly contact our sales window correspondents.

6 RECOMMENDED PCB LAYOUT

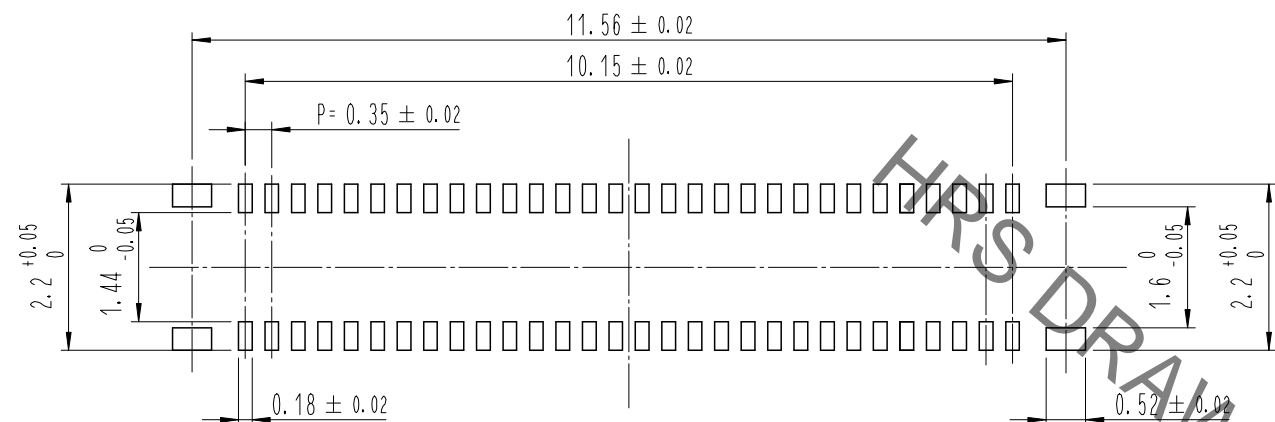

RECOMMENDED METAL MASK DIMENSIONS
MATAL MASK THICKNESS : 100 μm

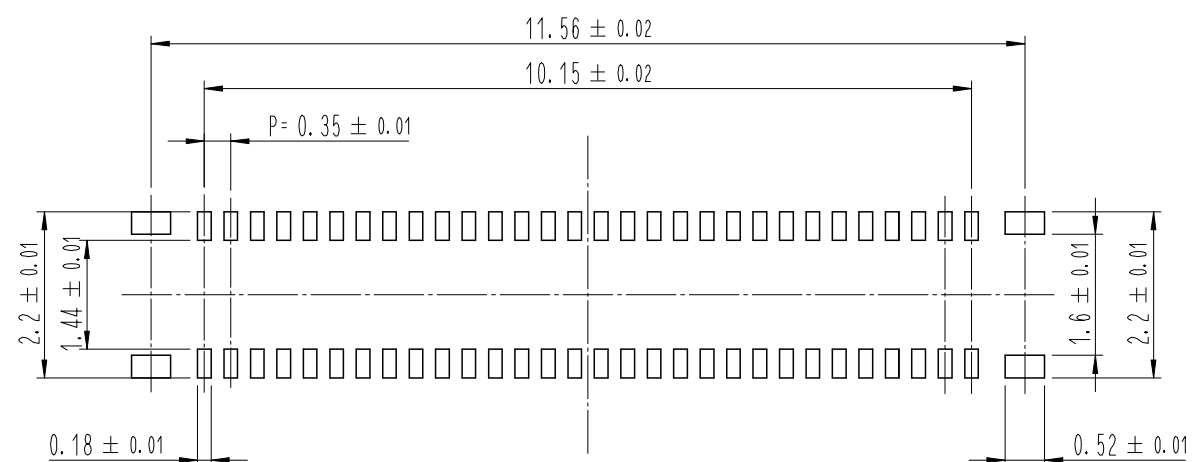

5 RECOMMENDED REFLOW TEMPERATURE PROFILE USING LEAD-FREE SOLDER PASTE.

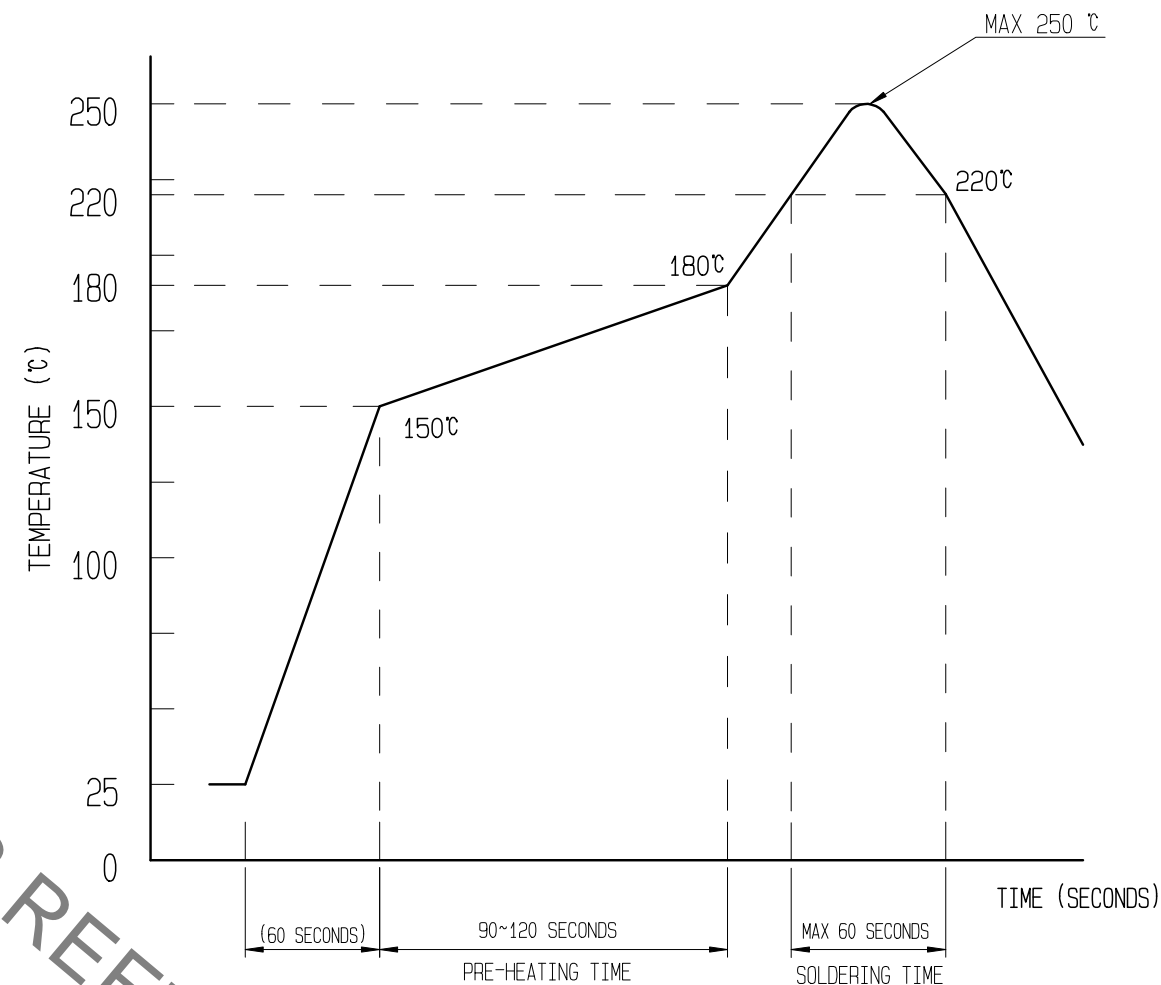

REFLOW METHOD: IR REFLOW
 NUMBER OF REFLOW CYCLES: 2 CYCLES MAX.
 1) REFLOW TIME
 DURATION ABOVE 220°C, 60 SEC MAX.
 (PEAK TEMPERATURE: 250°C MAX)
 2) PRE-HEAT TIME
 PRE-HEAT TEMPERATURE(MIN): 150°C
 PRE-HEAT TEMPERATURE(MAX): 180°C
 PRE-HEAT TIME: 90-120 SEC.

- 5 THIS TEMPERATURE PROFILE IS PER THE CONDITIONS SHOWN ABOVE. ADDITIONAL FACTORS, SUCH AS SOLDER PASTE TYPE, PCB SIZE AND OTHER MOUNTED COMPONENTS COULD AFFECT THE PROFILE, THEREFORE, A THOROUGH EVALUATION OF MOUNTING CONDITION IS REQUIRED PRIOR TO PRODUCTION. TEMPERATURE IS MEASURED AT CONTACT LEAD.
- 6 PLEASE CONTACT US IN CASE YOU WILL MAKE DIFFERENT SETTINGS FROM OUR RECOMMENDATION.

 SCALE 10:1 UNITS mm	DRAWING NO. EDC3-632085	PART NO. BM23FR0.8-60DS-0.35V(51)
	HIROSE KOREA CO., LTD.	CODE NO CL 6644-0028-3-051

May.1.2023 Copyright 2023 HIROSE ELECTRIC CO., LTD. All Rights Reserved.
In case of consideration for using Automotive equipment / device which demand high reliability, kindly contact our sales window correspondents.

EMBOSSED CARRIER TAPE PACKAGING (5:1)

C-C (5:1)

STYLE AND DIMENTION OF REEL (FREE)

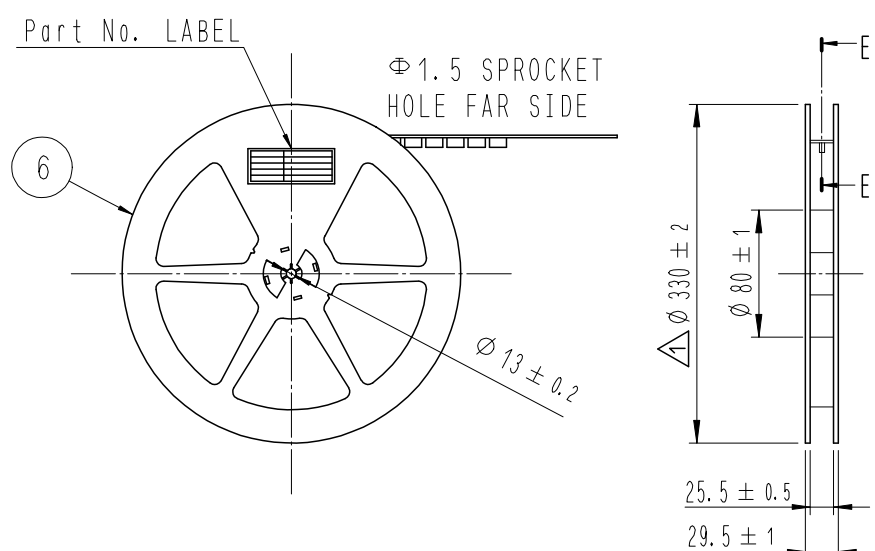
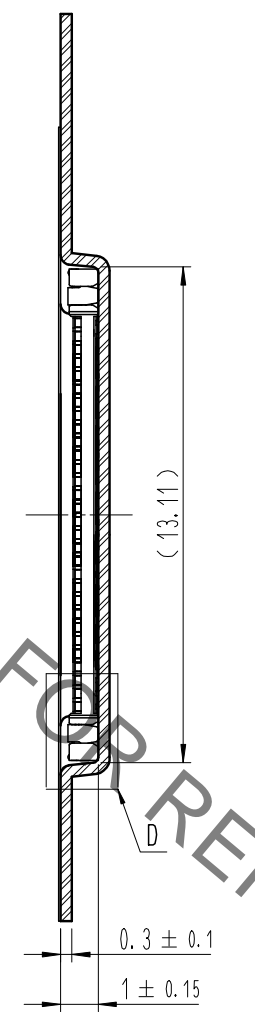
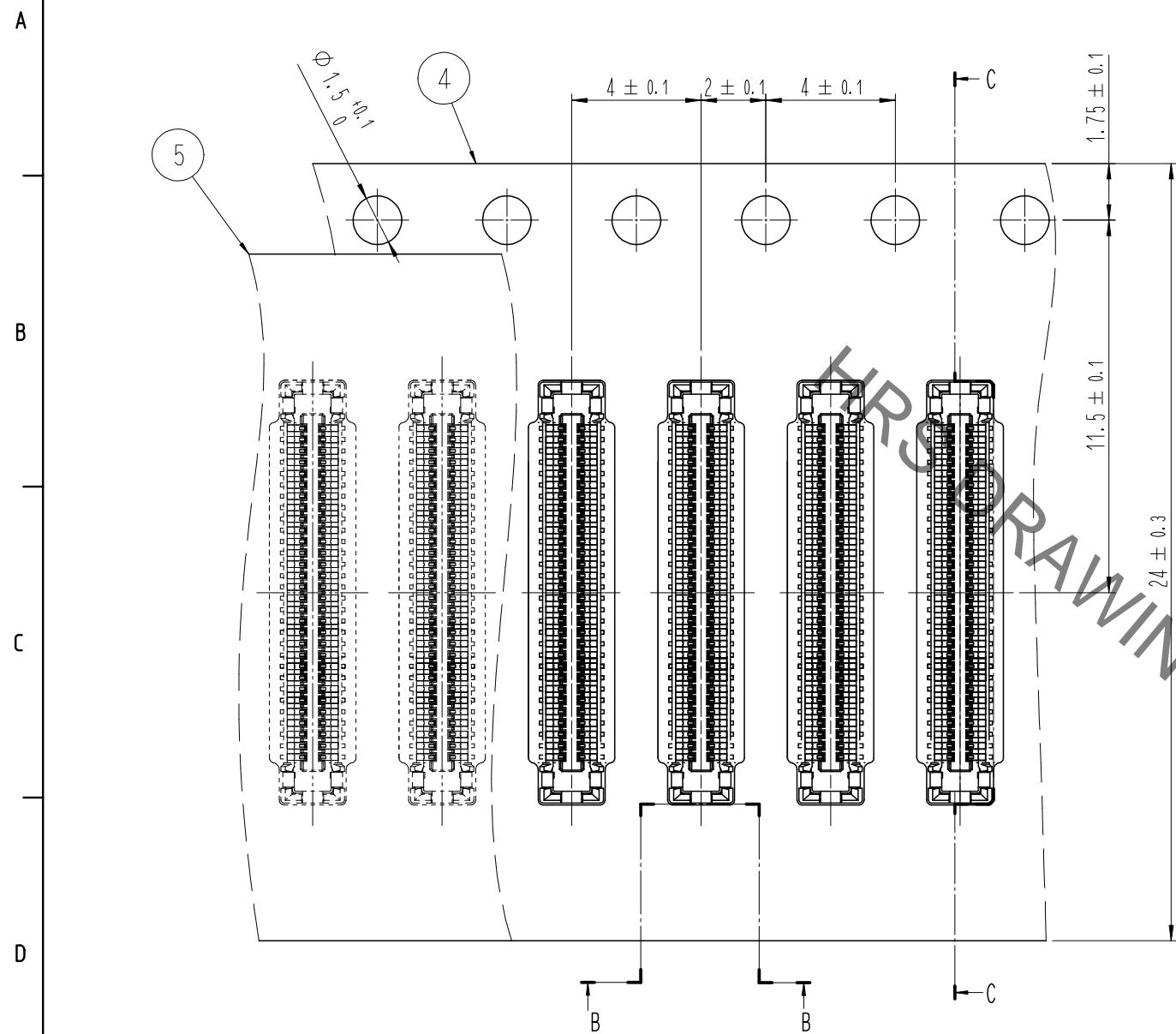

E-E (FREE)

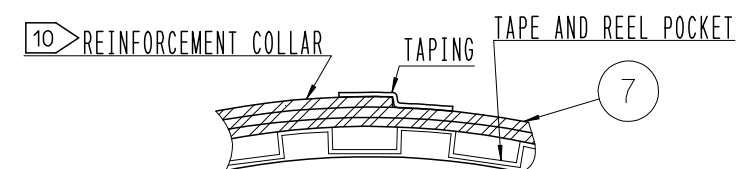

DETAIL OF PART No. LABEL

SUPPLIER	
QUANTITY	
PART NO.	
CODE NO.	
DATE OF MANUFACTURED	
生産月日	年 月 日
図番	** ** *
品名	BM23FR0.8-60DS-0.35V(51)
納入数量	10,000個
納入者	HIROSE KOREA

B-B (5:1)

DIRECTION OF UNREELING

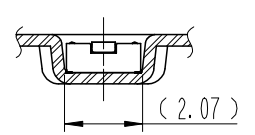

9 TAPING(FREE)

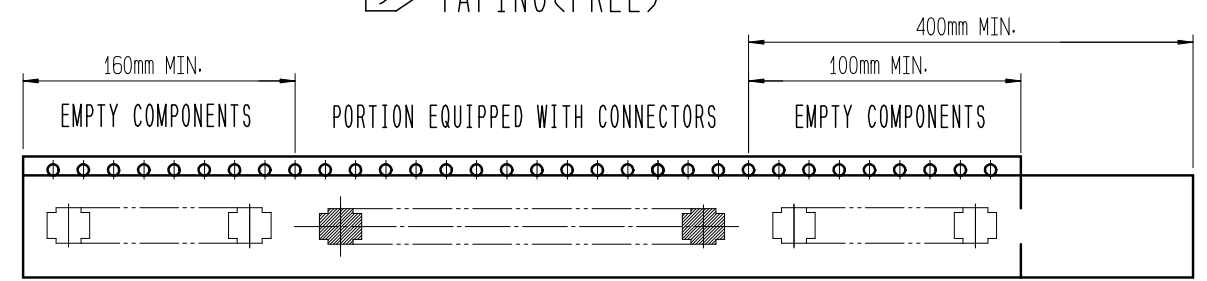

D (10:1)

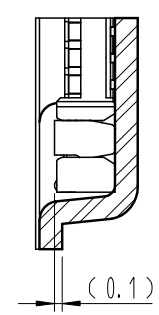

- 7 . PER REEL 10,000 CONNECTORS.
- 8 . THE DIMENSIONS IN PARENTHESES ARE FOR REFERENCE.
- 9 REFER TO JIS C 0806, IEC-60286-3 (PACKAGING OF COMPONENTS FOR AUTOMATIC HANDLING)
- 10 AFTER PACKAGING, ROLL 2 METERS OF THE REINFORCEMENT COLLAR TO OUTER CIRCUMFERENCE OF TAPE AND REEL POCKET. AND TAPE DOWN AT THE END THE COLLAR.

DRAWING NO. EDC3-632085	PART NO. BM23FR0.8-60DS-0.35V(51)	
	SCALE 10:1	CODE NO. CL 6644-0028-3-051
UNITS mm	HIROSE KOREA CO., LTD.	