

THIS DRAWING IS UNPUBLISHED. RELEASED FOR PUBLICATION
 © COPYRIGHT - By - ALL RIGHTS RESERVED.

LOC	DIST	REVISIONS			
P	LTR	DESCRIPTION	DATE	DWN	APVD
AF	50	C5	ECR-13-016672	25OCT13	PKS RRP

- 1 CONTINUOUS STRIP ON REELS WITH TERMINALS LOCATED ON 5.59±0.08 [.220±.003] CENTERS.
- 2 SLOT TERMINATES EITHER A SINGLE OR DOUBLE MAGNET WIRE OF THE SAME SIZE AND TYPE. COPPER RANGE: 0.91-1.02mm [#19-#17] AWG.
- 3 SPECIAL CAVITY ANVIL LOCATION REQUIRED 4.83±0.07[.190±.003] REF APPLICATION SPEC 114-2046, SEC. 3.2 NOTE 7 REVISION T OR LATER.

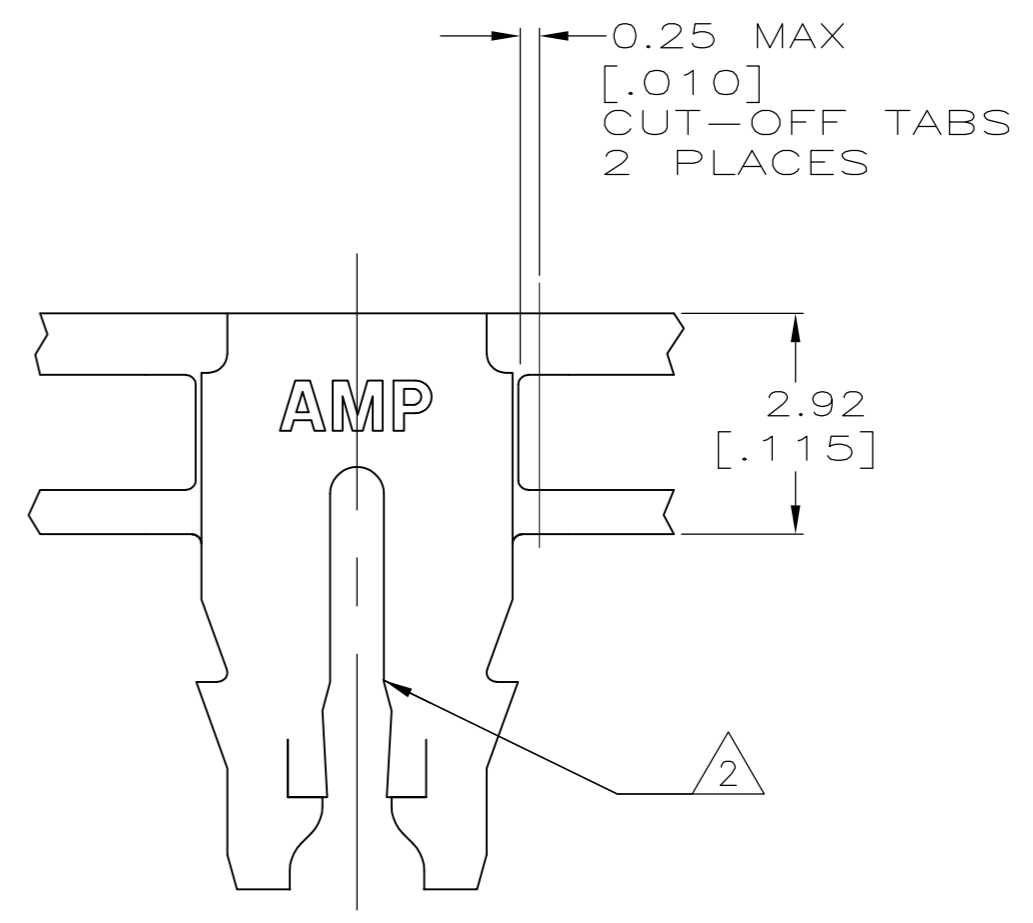
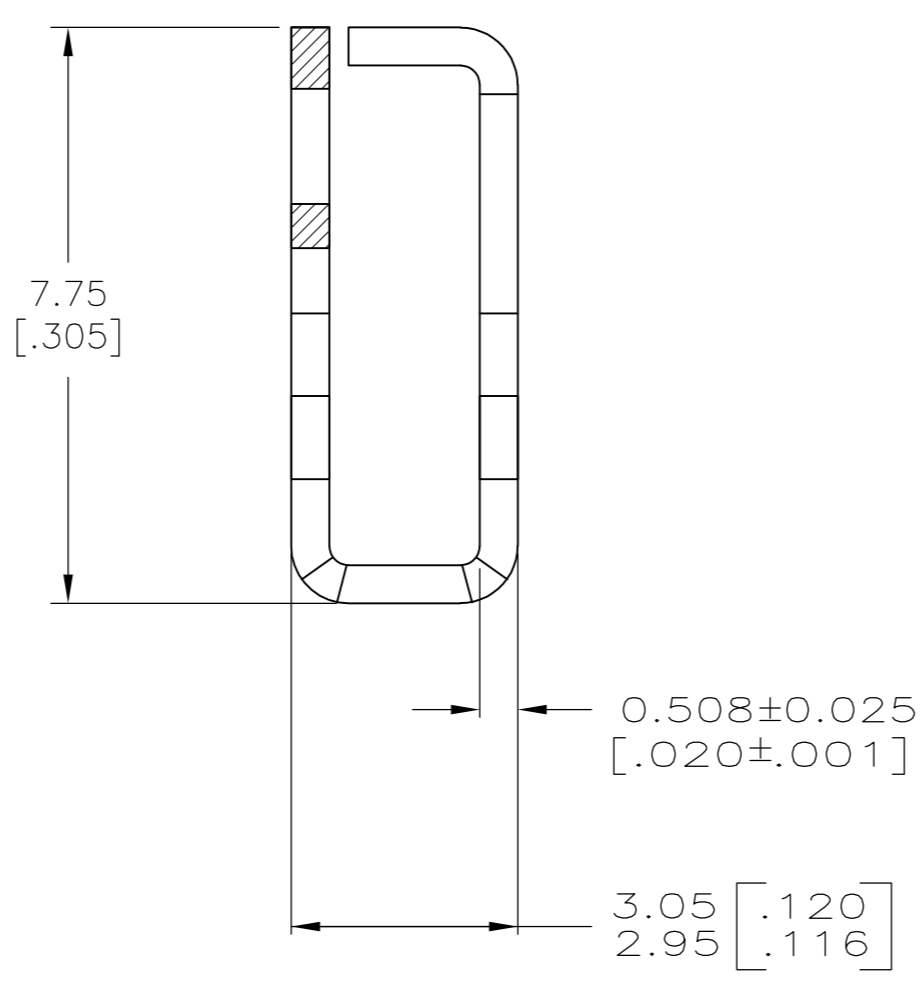
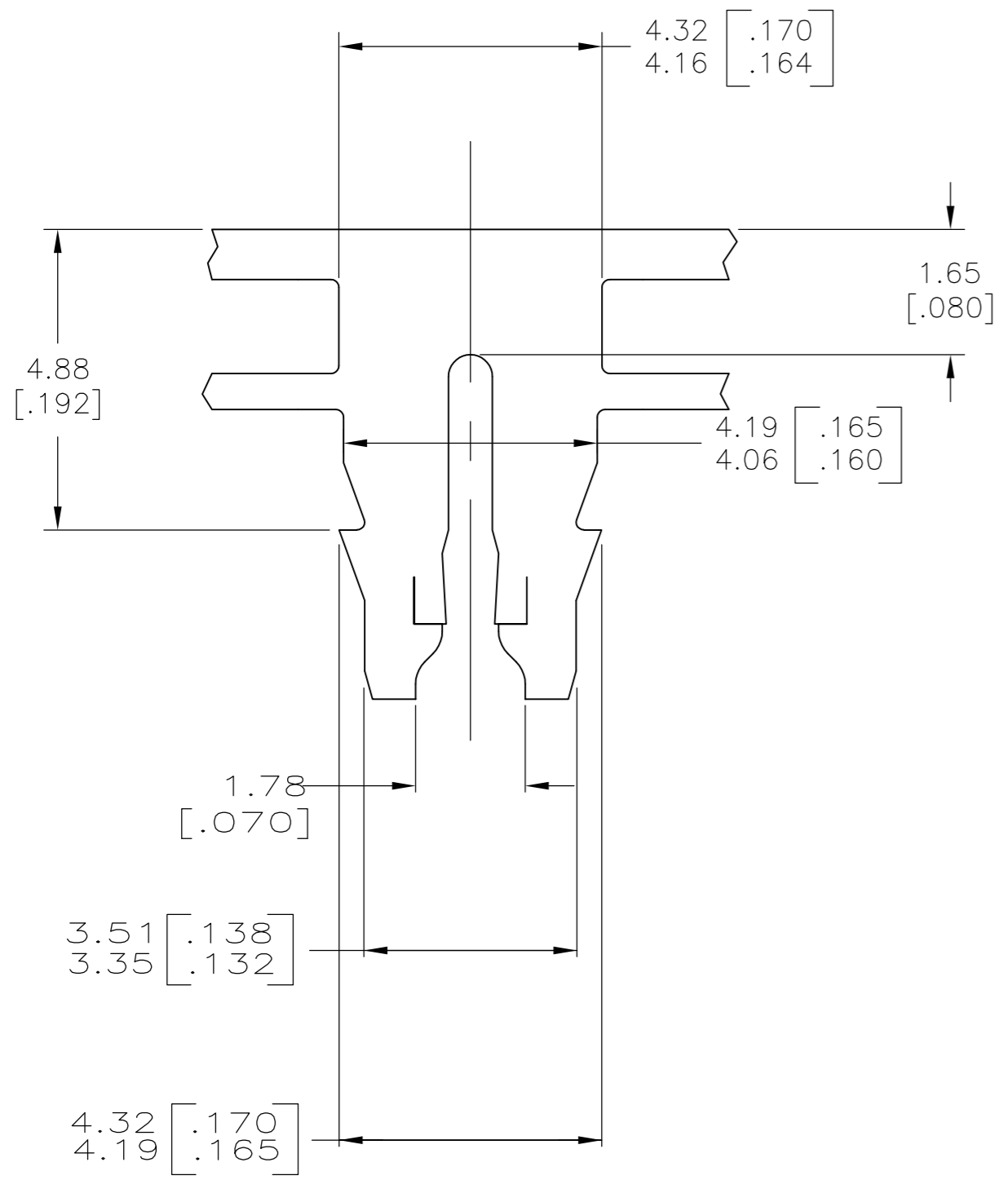
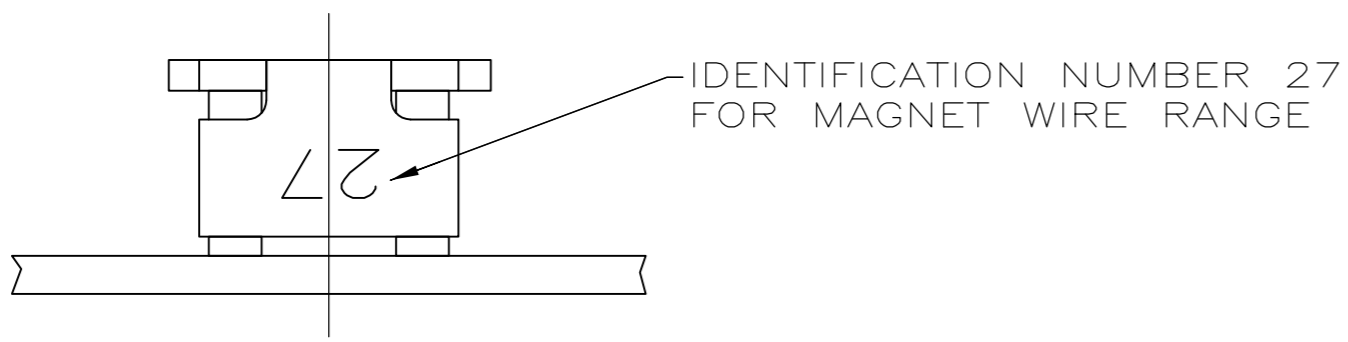

REVERSE	1742159-2
STANDARD	1742159-1
REELING	PART NUMBER

THIS DRAWING IS A CONTROLLED DOCUMENT.		DWN 11AUG2004 MICHAEL S. FEHER	TE TE Connectivity	
DIMENSIONS: mm [INCHES]		CHK 11AUG2004 KURT A. RANDOLPH		
TOLERANCES UNLESS OTHERWISE SPECIFIED:		APVD 11AUG2004 KURT A. RANDOLPH	NAME	
0 PLC ± -	1 PLC ± -	PRODUCT SPEC	TERMINAL, SPLICE, 300 SERIES MAG-MATE	
2 PLC ± 0.25 [.010]	3 PLC ± -	APPLICATION SPEC	SIZE	CAGE CODE
4 PLC ± -	ANGLES ± -	114-2046 3	A2	00779
MATERIAL BRASS	FINISH TIN PLATE	WEIGHT -	DRAWING NO	RESTRICTED TO
		CUSTOMER DRAWING	SCALE 10:1	SHEET 1 OF 1
			REV C5	