

May.1.2023 Copyright 2023 HIROSE ELECTRIC CO., LTD. All Rights Reserved.
 In case of consideration for using Automotive equipment / device which demand high reliability, kindly contact our sales window correspondents.

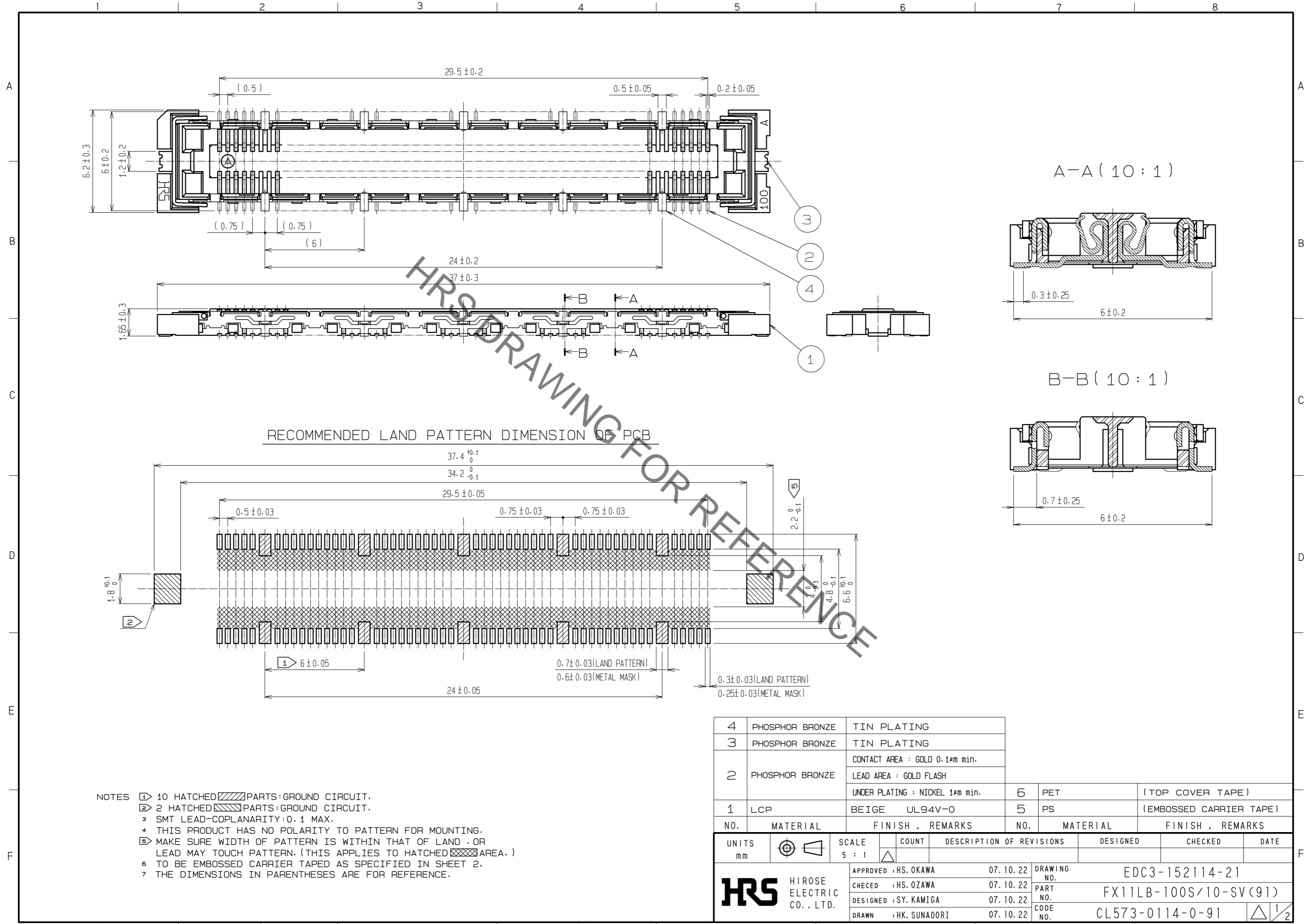

NOTES

- 10 HATCHED PARTS:GROUND CIRCUIT.
- 2 HATCHED PARTS:GROUND CIRCUIT.
- SMT LEAD-COPLANARITY:0.1 MAX.
- THIS PRODUCT HAS NO POLARITY TO PATTERN FOR MOUNTING.
- MAKE SURE WIDTH OF PATTERN IS WITHIN THAT OF LAND ,OR LEAD MAY TOUCH PATTERN.(THIS APPLIES TO HATCHED AREA.)
- TO BE EMBOSSED CARRIER TAPED AS SPECIFIED IN SHEET 2.
- THE DIMENSIONS IN PARENTHESSES ARE FOR REFERENCE.

4	PHOSPHOR BRONZE	TIN PLATING						
3	PHOSPHOR BRONZE	TIN PLATING						
2	PHOSPHOR BRONZE	CONTACT AREA : GOLD 0.1 μ m min.	6	PET	(TOP COVER TAPE)			
		LEAD AREA : GOLD FLASH						
1	LCP	BEIGE UL94V-0	5	PS	(EMBOSSED CARRIER TAPE)			
NO.	MATERIAL	FINISH . REMARKS	NO.	MATERIAL	FINISH . REMARKS			
UNITS mm			SCALE 5 : 1	COUNT 	DESCRIPTION OF REVISIONS	DESIGNED	CHECKED	DATE
HRS HIROSE ELECTRIC CO., LTD.		APPROVED : HS. OKAWA	07.10.22	DRAWING NO.	EDC3-152114-21			
		CHECED : HS. OZAWA	07.10.22	PART NO.	FX11LB-100S/10-SV(91)			
		DESIGNED : SY. KAMIGA	07.10.22	CODE NO.	CL573-0114-0-91			
		DRAWN : HK. SUNADORI	07.10.22		1/2			

May.1.2023 Copyright 2023 HIROSE ELECTRIC CO., LTD. All Rights Reserved.
 In case of consideration for using Automotive equipment / device which demand high reliability, kindly contact our sales window correspondents.

DRAWING FOR PACKING (2:1)

REELED DIMENSION (Free)

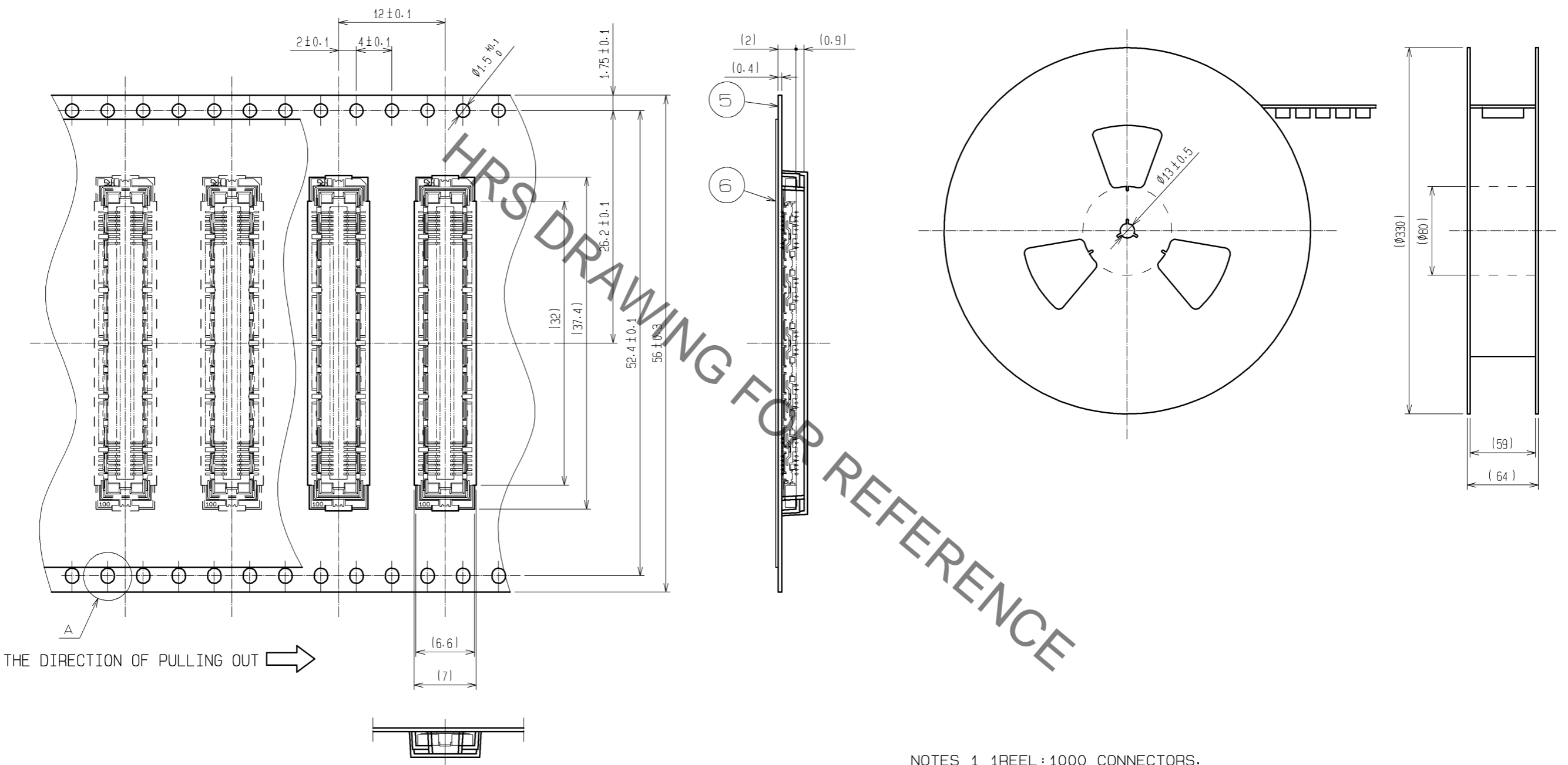

HRS DRAWING FOR REFERENCE

- NOTES
- 1 1 REEL : 1000 CONNECTORS.
 - 2 MINIMUM 10 COMPARTMENTS FROM BOTH REEL ENDS REMAIN EMPTY.
 - 3 THIS PRODUCT HAS NO POLARITY TO TAPE AND REEL PACKAGING.
 - 4 THE DIMENSIONS IN PARENTHESES ARE FOR REFERENCE.

HRS	DRAWING NO.	EDC3-152114-21	
	PART NO.	FX11LB-100S/10-SV(91)	
	CODE NO.	CL573-0114-0-91	△ 2/2